

morphy richards®



Traditional kettle

Please read and keep these instructions

GB

Bouilloire traditionnelle

Merci de bien vouloir lire et conserver ces instructions

F

Wasserkocher traditionell

Lesen Sie diese Bedienungsanleitung, und heben Sie sie gut auf

D

Tetera tradicional

Lea estas instrucciones atentamente y guárdelas

E

Traditionele waterkoker

Lees deze instructies en bewaar ze op een veilige plaats

NL

Jarro eléctrico tradicional

Leia e guarde estas instruções

P

Bollitore tradizionale

Leggere e conservare le presenti istruzioni

I

Almindelig kedel

Læs og gem venligst denne vejledning

DK

Vanlig vattenkokare

Läs och behåll dessa anvisningar

S

Czajnik tradycyjny

Prosimy zapoznać się z niniejszą instrukcją obsługi i zachować ją do użytku w przyszłości

PL

Традиционный чайник

Пожалуйста, прочтите и сохраните данное руководство

RU

Tradiční konvice

Přečtěte si tyto pokyny a uschovejte je

CZ

Geleneksel su ısıtıcı

Lütfen bu talimatları okuyun ve saklayın

TR



www.morphyrichards.com



Aust

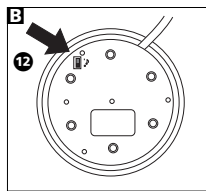
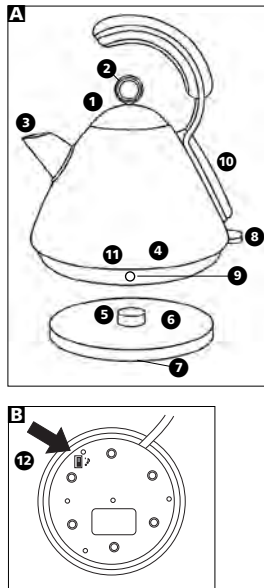
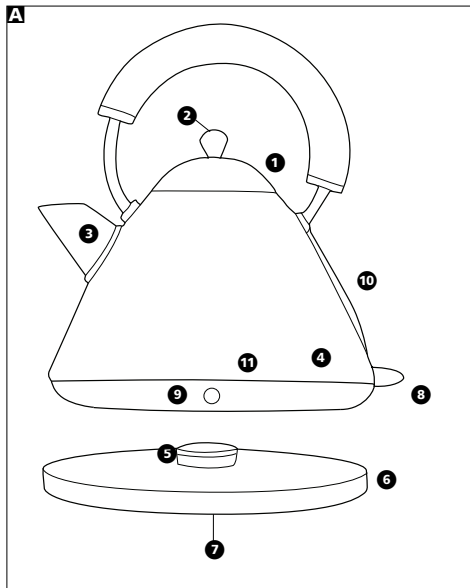

Getting the best from your new kettle...

Empty the water out of the kettle after first boiling

To clean away any deposits that are left in the kettle after the manufacturing process.

Descale as appropriate for the hardness of the water in your area

It is important to descale as the performance of the kettle and auto switch-off will be impaired.

Safety first

Always pour water slowly and carefully to prevent the splashing of scalding water.

Fast boil kettles perform differently

If your kettle is a fast boil model, it may sound louder during boiling, and switch off suddenly with no after noise - this is normal.

Important safety instructions

The use of any electrical appliance requires the following common sense safety rules.

Primarily there is danger of injury or death and secondly the danger of damage to the appliance. These are indicated in the text by the following two conventions:

WARNING: Danger to the person!

IMPORTANT: Damage to the appliance!

In addition we offer the following safety advice.

Location

- This appliance is intended to be used in household and similar applications such as: farm houses; by clients in hotels, motels and other residential type environments; bed and breakfast type environments. It is not suitable for use in staff kitchen areas in shops, offices and other working environments.
- Always locate your kettle away from the edge of the worktop.
- Ensure that the kettle is used on a firm, flat surface.
- Do not use the kettle outdoors or in a bathroom.

- **WARNING: Do not place the kettle onto a metal tray or metal surface whilst in use.**

Personal safety

- **WARNING: To protect against fire, electric shock and personal injury do not immerse cord, plug or kettle in water or any other liquid.**
- Position the lid so that steam is directed away from the handle.
- Do not remove the lid while the water is boiling.
- The kettle is only to be used with the stand provided.
- Do not attempt to connect any other appliance to the base unit or this appliance to another base unit.
- Always pour hot water slowly and carefully without tipping the kettle too fast to prevent splashing and spillage.
- Do not move the kettle when switched on.
- Extreme caution must be used when moving a kettle containing hot water.
- Do not touch hot surfaces, use handles or knobs.
- Always close the lid securely, otherwise the kettle may not switch off automatically and may spit out boiling water.
- Avoid contact with steam from the spout when the water is boiling or just after it has switched off.
- Take care if opening the lid for re-filling when the kettle is hot.
- Do not fill above the MAX mark, otherwise boiling water may be ejected.
- Do not hold the switch in the on position or tamper with the switch to fix it in the on position as this may cause damage to the switch-off mechanism.
- Unplug from the outlet before cleaning.
- Allow to cool before putting on or taking off parts and before cleaning.
- This appliance is not intended to be used by young children or infirm persons without supervision.
- This appliance is not intended for use by persons (including children) with reduced physical, sensory or mental capabilities, or lack of experience and knowledge, unless they have been given supervision or instruction concerning use of the appliance by a person responsible for their safety.



Mains lead

- The mains lead should reach from the socket to the base unit without straining the connections. Reduce the length of the lead by storing the excess in the cord storage facility in the base unit.
- Do not let the mains lead hang over the edge of the worktop where a child could reach it.
- Do not let the lead run across an open space e.g. between a low socket and table.
- Do not let the lead run across a cooker or toaster or other hot area which might damage the cable.
- Do not place the kettle where the mains lead could fall into a sink.
- If the supply cord is damaged it must be replaced by the manufacturer or its service agent or similarly qualified person in order to avoid a hazard.

Children

- Children do not understand the dangers associated with operating electrical appliances. Never allow children to use this appliance.
- Young children should be supervised to ensure they do not play with the appliance.

Other safety considerations

- Do not operate any appliance with a damaged cord or plug or after the appliance malfunctions or has been damaged in any manner. Ring the helpline number for advice on examination and repair.
- The use of attachments or tools not recommended or sold by Morphy Richards may cause fire, electric shock or injury.
- Do not tamper with the connector in any way.
- Do not use the kettle for any use other than to boil water.
- Do not use outdoors.
- Do not place the kettle on or near a hot gas or electric burner or in a heated oven.
- The kettle must not be on the base unit when being filled with water.
- Morphy Richards does not recommend that the mains lead of the cordless base cannot be repaired. If the mains lead is damaged, the cordless base should be discarded and replaced.
- Unplug from the outlet when not in use.
- Do not leave unattended whilst in use.
- Always keep the top of the cordless base dry, especially around the connection area, disconnect the power supply before drying. Allow to dry thoroughly before reconnection to the power supply.
- Caution: to prevent damage to the appliance, do not use alkaline cleaning agents when cleaning, use a cloth and mild detergent.
- Ensure that the kettle is switched off before removing it from its base.

Treating scalds

- Run cold water over the affected area immediately. Do not stop to remove clothing, get medical help quickly.

Electrical requirements

Check that the voltage on the rating plate of your appliance corresponds with your house electricity supply which must be 220 - 240 volts AC.

WARNING: This appliance must be earthed.

UK only

If the socket outlets in your home are not suitable for the plug supplied with this appliance, the plug should be removed and the appropriate one fitted.

WARNING: The plug removed from the mains lead, if severed, must be destroyed as a plug with bared flexible cord is hazardous if engaged into a live socket outlet.

Where used, should the fuse in the 13 amp plug require replacement, a 13 amp BS1362 fuse must be fitted.

Features

- 1 Lid
- 2 Lid knob
- 3 Spout filter
- 4 Concealed element
- 5 360° connector
- 6 Cordless base unit
- 7 Cord storage
- 8 On/off switch
- 9 Power on neon
- 10 Water level indicator
- 11 Concealed element (inside)
- 12 Whistle on/off switch

Using

Filling the kettle

- 1 Wherever possible fill through the spout, as this helps to free the filter from limescale build-up.
- The integrated water level indicator allows you to easily see the amount of water in the kettle.
- Always ensure that the level of water in the kettle is filled to at least the minimum level shown on the water gauge. Should your kettle not have a water gauge, always ensure that the element is covered.
- Boil only as much water as you need as this saves electricity.
- 2 Place the kettle on the base unit, ensuring the kettle locates on to the 360° connector.
- The 360° connector allows the kettle to be located at any position. - ideal for left and right handed users and for convenient positioning on the worktop.
- 3 Plug in and switch on at the wall socket.
- 4 Switch the kettle on. The 'power on' neon will light up.
- 5 When the water boils the kettle will switch off automatically.
- If you are using the kettle for the first time, pour away the boiled water and refill.
- 6 Lift the kettle from the base unit by the handle ensuring you hold the kettle level.
- To re-boil, switch to ON again. If the kettle has just switched off wait a minute or so before switching it back on again.
- If you do not put in enough water, or switch on the kettle when it is empty, the safety cut-out will switch off the power automatically. If this happens, refill and wait a few minutes for the element to cool, then use as normal.

Filter removal

- 1 Open the lid.
- 2 Lift the filter upwards from its holder.
- 3 To refit the filter, slide it into the side wall guides of the filter holder until it clicks into place.

WARNING: Unless the filter is fitted correctly, the kettle lid may not close and lock securely.

Descaling

IMPORTANT: As this kettle is fitted with a concealed element it must be descaled regularly. The frequency of descaling depends on usage and the hardness of the water in your area.

Excessive scale can cause the kettle to switch off before boiling and may damage the element invalidating the warranty.

It is essential that regular descaling takes place.

Remove hard scale using a proprietary descaling product suitable for stainless steel kettles.

Alternatively use citric acid crystals (available from most pharmacies) as follows.

- 1 Fill the kettle 3/4 full, boil, then unplug the kettle (remove the cordless kettle from the base unit) and stand it in an empty sink or bowl.



- 2 Add 50gm of citric acid crystals to the water gradually, then leave the kettle to stand. Do not use a more concentrated solution.
- 3 As soon as the effervescence subsides, empty the kettle and rinse it thoroughly with cold water.
- 4 Wipe the outside of the kettle thoroughly with a damp cloth to remove all traces of acid which may damage the finish. **IMPORTANT:** Ensure that the electrical connections are completely dry before using the kettle.

Cleaning

WARNING: Always disconnect the plug from the mains and allow the kettle to cool before cleaning.

CAUTION: To prevent damage to the appliance do not use alkaline cleaning agents when cleaning, use a soft cloth and a mild detergent.

Wipe the outside with a damp cloth.

IMPORTANT: Do not use abrasive cleaners on the outside of the kettle which may scratch the surface.

Whistle feature

- There is a switch  on the cordless base of the product that can switch the whistle on and off as desired.

THIS SECTION IS ONLY APPLICABLE FOR CUSTOMERS IN UK AND IRELAND

REGISTERING YOUR TWO YEAR GUARANTEE

Your standard one year guarantee is extended for an additional 12 months when you register the product within 28 days of purchase with Morphy Richards. If you do not register the product with Morphy Richards within 28 days, your product is guaranteed for 1 year. To validate your 2 year guarantee register with us online at www.morphyrichards.co.uk

N.B. Each qualifying product needs to be registered with Morphy Richards individually. Please note that the 2 year guarantee is only available in the UK and Ireland. Please refer to the one year guarantee for more information.

YOUR ONE YEAR GUARANTEE

It is important to retain the retailer's receipt as proof of purchase. Staple your receipt to this back cover for future reference. Please quote the following information if the product develops a fault. These numbers can be found on the base of the product.

Model no.

Serial no.

All Morphy Richards products are individually tested before leaving the factory. In the unlikely event of any appliance proving to be faulty within 28 days of purchase, it should be returned to the place of purchase for it to be replaced. If the fault develops after 28 days and within 12 months of original purchase, you should contact the Helpline number quoting Model number and Serial number on the product, or write to Morphy Richards at the address shown. You may be asked to return a copy of proof of purchase. Subject to the exclusions set out below (see Exclusions), the faulty appliance will then be repaired or replaced and dispatched usually within 7 working days of receipt. If, for any reason, this item is replaced during the 1 year guarantee period, the guarantee on the new item will be calculated from original purchase date. Therefore it is vital to retain your original till receipt or invoice to indicate the date of initial purchase. To qualify for the 1 year guarantee, the appliance must have been used according to the instructions supplied. For example, crumb trays should have been emptied regularly.

EXCLUSIONS

Morphy Richards shall not be liable to replace or repair the goods under the terms of the guarantee where:

- 1 The fault has been caused or is attributable to accidental use, misuse, negligent use or used contrary to the manufacturer's recommendations or where the fault has been caused by power surges or damage caused in transit.
- 2 The appliance has been used on a voltage supply other than that stamped on the products.
- 3 Repairs have been attempted by persons other than our service staff (or authorised dealer).
- 4 The appliance has been used for hire purposes or non domestic use.
- 5 The appliance is second hand.
- 6 Morphy Richards are not liable to carry out any type of servicing work, under the guarantee.
- 7 Plastic filters for all Morphy Richards kettles and coffee makers are not covered by the guarantee.
- 8 Batteries and damage from leakage are not covered by the guarantee. This guarantee does not confer any rights other than those expressly set out above and does not cover any claims for consequential loss or damage. This guarantee is offered as an additional benefit and does not affect your statutory rights as a consumer.

YOUR INTERNATIONAL TWO-YEAR GUARANTEE

This appliance is covered by two-year repair or replacement warranty.

It is important to retain the retailers receipt as proof of purchase. Staple your receipt to this back cover for future reference.

Please quote the following information if the product develops a fault. These numbers can be found on the base of the product.

Model no.

Serial no.

All Morphy Richards products are individually tested before leaving the factory. In the unlikely event of any appliance proving to be faulty within 28 days of purchase it should be returned to the place of purchase for it to be replaced.

If the fault develops after 28 days and within 24 months of original purchase, you should contact Morphy Richards quoting Model number and Serial number on the product, or write to Morphy Richards at the address shown.

You will be asked to return the product (in secure, adequate packaging) to the address below along with a copy of proof of purchase.

Subject to the exclusions set out below (1-8) the faulty appliance will then be repaired or replaced and dispatched usually within 7 working days of receipt.

If for any reason this item is replaced during the 2-year guarantee period, the guarantee on the new item will be calculated from original purchase date. Therefore it is vital to retain your original till receipt or invoice to indicate the date of initial purchase.

To qualify for the 2-year guarantee the appliance must have been used according to the manufacturers instructions. For example, appliances must have been descaled and filters must have been kept clean as instructed.

Morphy Richards shall not be liable to replace or repair the goods under the terms of the guarantee where:

- 1 The fault has been caused or is attributable to accidental use, misuse, negligent use or used contrary to the manufacturers recommendations or where the fault has been caused by power surges or damage caused in transit.
- 2 The appliance has been used on a voltage supply other than that stamped on the products.
- 3 Repairs have been attempted by persons other than our service staff (or authorised dealer).

- 4 Where the appliance has been used for hire purposes or non domestic use.
- 5 The appliance is second hand.
- 6 Morphy Richards are not liable to carry out any type of servicing work, under the guarantee.
- 7 The guarantee excludes consumables such as bags, filters and glass carafes.
- 8 Batteries and damage from leakage are not covered by the guarantee. This guarantee does not confer any rights other than those expressly set out above and does not cover any claims for consequential loss or damage. This guarantee is offered as an additional benefit and does not affect your statutory rights as a consumer.

AUSTRALIAN WARRANTY

This appliance is guaranteed for 2 years against faulty material, components and workmanship.

This warranty is in addition and does not affect your statutory rights.

Proof of purchase must be produced for any warranty benefit.

In the unlikely event of any appliance proving to be faulty, securely pack and return the item to the place of purchase accompanied by the original receipt or invoice.

NOT COVERED BY THIS WARRANTY (Australian only)

- If the appliance has not been used in accordance with the manufacturers' recommendations or Instructions.
- If the fault is deemed to be caused by abuse, misuse, neglect, modifications or in proper use and or care
Eg: Kettles: Excessive build up of scale.
Toasters: Excessive build up of crumbs or foreign matter etc.
- Connection to incorrect voltage to that stamped on the product.
- Unauthorised repairs.
- Appliance used other than for domestic purposes.
- Excluding bags, filters, glass, carafes, and cutting blades.
- Freight and insurance costs.

If for any reason this item is replaced during the 2 year guarantee period, the guarantee on the new item will be calculated from original purchase date. Therefore it is vital to retain your original receipt or invoice to indicate the date of original purchase.

Morphy Richards's policy is to continually improve quality design and product quality. The company therefore reserves the right to change any specifications or to carry out modifications as deemed worthy at any time.

The Australian supplier ASKO Appliances reserves the right to repair, modify, exchange or replace the faulty appliance with the same or similar model or product of equivalent value.

F

Pour utiliser au mieux votre nouvelle bouilloire...

Videz l'eau de la bouilloire après la première utilisation

Pour supprimer les dépôts pouvant rester dans la bouilloire après le processus de fabrication.

Détartrez l'appareil en fonction de la dureté de l'eau de votre région

Il est important de détartre la bouilloire, car le tartre affecte son efficacité et gêne le fonctionnement de l'arrêt automatique.

Priorité à la sécurité

Versez toujours l'eau lentement et avec soin pour éviter toute ébullition d'eau bouillante.

Les bouilloires "Fast boil" fonctionnent différemment

Si votre bouilloire est un modèle "Fast boil", elle vous semblera peut-être plus bruyante pendant l'ébullition et elle s'arrêtera d'un coup, en même temps que le bruit – ceci est normal.

Consignes de sécurité importantes

Lorsque vous utilisez tout appareil électrique, vous devez respecter des consignes de sécurité de bon sens.

Tout appareil électrique peut blesser ou même provoquer la mort. Vous risquez également d'endommager l'appareil. Ces dangers sont indiqués dans le texte par les deux conventions suivantes :

DANGER : Risque de blessure !

IMPORTANT : Risque pour l'appareil !

Nous vous donnons également les conseils de sécurité suivants.

Positionnement

- Cet appareil est conçu pour être utilisé dans des applications domestiques et similaires telles que : les fermes ; par les clients dans les hôtels, motels et autres environnements de type résidentiel ; les environnements de type "Bed and Breakfast". Il ne convient pas pour une utilisation dans les cuisines réservées au personnel des magasins, bureaux et autres lieux de travail.
- Positionnez toujours votre bouilloire loin du bord du plan de travail.
- Utilisez la bouilloire sur une surface solide et plate.
- N'utilisez jamais la bouilloire à l'extérieur ou dans une salle de bains.
- **DANGER : Ne placez pas la bouilloire sur un plateau en métal ou sur une surface métallique pendant qu'elle fonctionne.**

GB

F

Sécurité personnelle

- **DANGER : Pour vous protéger des risques d'incendie, de choc électrique et de blessure, ne plongez pas le cordon d'alimentation, la fiche électrique ou la bouilloire elle-même dans l'eau ou dans d'autres liquides.**
- Positionnez le couvercle de façon à ce que la vapeur ne soit pas dirigée vers la poignée.
- Ne retirez pas le couvercle pendant que l'eau bout.
- La bouilloire doit être utilisée uniquement avec le socle fourni.
- Ne tentez pas de mettre un autre appareil sur le socle ou de mettre la bouilloire sur un autre socle.
- Versez toujours l'eau chaude lentement et soigneusement, sans incliner la bouilloire trop brutalement, afin d'éviter les éclaboussures et les débordements.
- Ne déplacez pas la bouilloire pendant qu'elle est sous tension.
- Vous devez faire très attention lorsque vous transportez une bouilloire qui contient de l'eau chaude.
- Ne touchez pas les surfaces chaudes et utilisez les poignées ou les boutons.
- Fermez toujours le couvercle à fond, sans quoi la bouilloire pourrait ne pas s'arrêter automatiquement et pourrait projeter de l'eau bouillante.
- Évitez d'entrer en contact avec la vapeur qui sort du bec verseur pendant l'ébullition ou juste après l'arrêt de la bouilloire.
- Faites attention si vous ouvrez le couvercle pour remplir la bouilloire alors qu'elle est encore chaude.
- Ne remplissez pas la bouilloire au-delà de la position MAX, sans quoi de l'eau bouillante pourrait être projetée.
- Ne tenez pas le commutateur en position marche et ne le modifiez pas pour le fixer en position marche, car ceci risque d'endommager le mécanisme d'arrêt automatique.
- Débranchez la bouilloire du secteur avant de la nettoyer.
- Laissez-la refroidir avant de monter ou de démonter des pièces et avant de la nettoyer.
- Cet appareil n'est pas destiné à être utilisé par de jeunes enfants ou des personnes infirmes sans supervision.
- Cet appareil n'est pas conçu pour être utilisé par des personnes (y compris les enfants) ayant des capacités physiques, sensorielles ou mentales réduites, ou un manque d'expérience et de connaissance, sauf si elles sont surveillées ou si elles ont reçu des instructions concernant l'utilisation de l'appareil par une personne responsable de leur sécurité.

- 25 Morphyrichards products are intended for household use only. See usage limitations within the location sub-heading in the important safety instructions. Morphyrichards has a policy of continuous improvement in product quality and design. The Company, therefore, reserves the right to change the specification of its models at any time.

The After Sales Division,

Morphyrichards Ltd, Mexborough, South Yorkshire, England, S64 8AJ
Helpline (office hours) UK 0845 871 0954 Republic of Ireland 1800 409119

- 26 Australia - Service centre locations

Asko Appliances (Australia) Pty Ltd.

Victoria
35 Sunmore Close, Moorabbin, 3189 T: 03 8551 2200

New South Wales

F3/3-9 Birnie Ave., Lidcombe, 2141 T: 02 8748 2900

Queensland

2/112 Fison Ave., Eagle Farm, 4009 T: 07 3623 2700

South Australia

45 Hampton Road, Keswick, 5035 T: 08 8293 1833

Western Australia

15 Walters Drive, Osborne Park, 6017 T: 08 9244 4366

- 27 Les produits Morphyrichards sont conçus pour un usage exclusivement domestique. Voir les limitations d'usage dans le sous-titre Positionnement des Consignes de sécurité importantes. Morphyrichards s'engage à mener une politique d'amélioration continue en termes de qualité et de conception. Le fabricant se réserve donc le droit de modifier sans préavis la spécification de ses modèles.

Glen Dimplex France

ZI de l'Eglantier
20, rue des Cersiers
91028 Evry cedex 2851

T: + 33 (0)1 69 11 11 91

F: + 33 (0)1 60 86 15 24

- 28 Morphyrichards Produkte sind nur für den Einsatz im Haushalt vorgesehen. Lesen Sie dazu die Einschränkungen bezüglich der Nutzung, die in der Zweitüberschrift der wichtigen Sicherheitshinweise erläutert werden. Ständige Verbesserungen an der Produktqualität und dem Design gehören zur Philosophie von Morphyrichards. Aus diesem Grund behält sich die Firma das Recht vor, die Angaben zu ihren Modellen jederzeit zu ändern.

Glen Dimplex Deutschland GmbH

Service-Hotline: +49(0) 1805/398 346 (0,14 Euro/Min)
Service-Fax: +49(0) 1805/355 467
email: service@glendimplex.de

Österreich

Kundendienst
Merangasse 17
A-8010 Graz

Telefon: +43(0) 316/323-041

Telefax: +43(0)316/382-963

- 29 Los productos Morphyrichards están concebidos solamente para uso doméstico. Consulte las limitaciones de uso en un subtítulo de las instrucciones de seguridad importantes. Morphyrichards tiene una política de mejora en la calidad y diseño de sus artículos. La compañía, por lo tanto, se reserva el derecho de cambiar en cualquier momento las especificaciones de sus modelos.

Glen Dimplex Benelux BV

Antennestraat 84
1322 AS Almere
Nederland

T: +31-(0)-36 538 70 40
Service: +31-(0)-36-538 70 55
E: info@glendimplex.nl

F: +31-(0)-36-538 70 41

www.morphyrichards.nl

- 30 Les produits Morphyrichards sont conçus pour un usage exclusivement domestique. Voir les limitations d'usage dans le sous-titre Positionnement des Consignes de sécurité importantes. Morphyrichards s'engage à mener une politique d'amélioration continue en termes de qualité et de conception. Le fabricant se réserve donc le droit de modifier sans préavis la spécification de ses modèles.

De producten van Morphyrichards zijn alleen bedoeld voor huishoudelijk gebruik. Zie gebruikbeperkingen binnen de locatiesubtitel in de belangrijke veiligheidsinstructies. Morphyrichards streeft ernaar de kwaliteit en het design van zijn producten voortdurend te verbeteren. Het bedrijf behoudt zich daarom het recht voor om de specificaties van de producten op ieder ogenblik te wijzigen.

Glen Dimplex Benelux BV

Gentsstraat 60
B- 9300 Aalst
Belgie

T: +32-(0)-53 82 88 62
E: info@glendimplex.be

F: +32-(0)-53 82 88 63
www.morphyrichards.be

- 31 Os produtos Morphyrichards foram concebidos apenas para utilização doméstica. Consulte as limitações à utilização no sub-cabeçalho de posicionamento, nas instruções importantes de segurança. A Morphyrichards respeita uma política de aperfeiçoamento contínuo da qualidade e design do produto. Desta forma, a companhia reserva-se o direito de alterar as especificações destes modelos a qualquer momento.

Imporaudio Lda

Rua D. Marcos Da Cruz 1281
4455-482 Penafita
Portugal

T: +351 22 996 67 40

Fax: +351 22 996 67 41

- 32 I prodotti Morphyrichards sono concepiti esclusivamente per uso domestico. Vedere le limitazioni d'uso nel sottotitolo delle importanti istruzioni di sicurezza. Morphyrichards è costantemente impegnata a migliorare la qualità e il design dei propri prodotti, pertanto si riserva il diritto di modificare le specifiche dei diversi modelli in qualunque momento.

Glen Dimplex Italia Srl

Via delle Rose 7, 24040 Lallio (BG)
Assistenza telefonica (Lun-Ven)
08:30 - 12:30 / 14:00 - 18:00

T: 035-201042

F: 035-200492

- 33 Morphyrichards produkter er kun beregnet til husholdningsbrug. Se brugsbegrænsningerne under overskriften om placering i de vigtige sikkerhedsinstruktioner. Det er praksis hos Morphyrichards at fortsætte udviklingen af produktets kvalitet og design. Firmaet forbeholder sig derfor retten til at ændre modellemes specifikationer når som helst.

- 34 Produkter från Morphyrichards är endast avsedda för hushållsbruk. Se användarbegränsningar under rubriken i de viktiga säkerhetsinstruktionerna. Morphyrichards har en policy för kontinuerlig förbättring i produktkvalitet och utformning. Företaget förbehåller sig därför rätten att när som helst ändra specifikationen för sina modeller.

- 35 Produkty Morphyrichards są przeznaczone wyłącznie do użytku domowego. Zapoznaj się z informacjami na temat ograniczonego użytkowania urządzeń, które znajdują się w podrzdziale instrukcji dotyczących bezpieczeństwa. Morphyrichards prowadzi politykę ciągłej poprawy jakości i wzoru produktów. Firma zastrzega sobie prawo zmiany specyfikacji modeli w dowolnej chwili.

Glen Dimplex Polska Sp. z o.o

Ul. Straszynska 33
60-479 Poznań
NIP 781-16-70-985

T: +48 (0)61 8425 805

F: +48 (0)61 8425 806

- 36 Изделия Morphyrichards предназначены только для бытового использования. См. информацию об ограничениях использования в подразделе "Размещение" в главе "Важные меры предосторожности". Morphyrichards постоянно совершенствует качество и дизайн своей продукции. Таким образом, компания оставляет за собой право в любое время вносить изменения в технические характеристики своих изделий.

- 37 Výrobky Morphyrichards jsou určeny pouze k použití v domácnostech. Podívejte se na omezení použití v podtitulku umístění v důležitých bezpečnostních pokynech. Morphyrichards usiluje o neustálé zdokonalování kvality a provedení. Proto si vyhrazuje právo kdykoliv změnit specifikace svých modelů.

Tauer Elektro a.s.

Milady Horákové 4
568 02 Svitavy

T: +420 461 540 130

F: +420 461 540 133

- 38 Morphyrichards ürünleri sadece ev içi kullanım amaçlıdır. Morphyrichards, ürün kalitesi ve tasarımında sürekli geliştime politikasına sahiptir. Bu nedenle Şirket, modellerinin özelliklerini herhangi bir zamanda değiştime hakkını saklı tutar.

Gizpa Dayanıklı Tüketim Mamülleri

Tic. ve Paz. İth. İhr. A.Ş.
Atatürk Cd. 19 Mayıs Mah. Esin Sok. No: 2/2
Kozyatağı-İSTANBUL

Tel +90(0216) 411 23 77

Fax +90(0216) 369 33 42

- 39 Should your Morphyrichards product become faulty, please do not return the product to the store, contact the Customer Care Help Line 086 111 5006 or e-mail help@creativehousewares.co.za for remedial action. For guarantee claims please furnish your proof of purchase and product serial number.

Creative Housewares

27 Nourse Ave; Epping 2; Cape Town; 7460
P.O. Box 975; Eppindurst; 7475

Tel: 021 534 8114

Fax 021 534 8086

www.creativehousewares.co.za





- GB** For electrical products sold within the European Community.
At the end of the electrical products useful life it should not be disposed of with household waste.
Please recycle where facilities exist.
Check with your Local Authority or retailer for recycling advice in your country.
- F** Pour les appareils électriques vendus dans la Communauté européenne.
Lorsque les appareils électriques arrivent à la fin de leur vie utile, il ne faut pas les jeter à la poubelle.
Il faut les recycler dans des centres spécialisés, s'ils existent.
Consultez la municipalité ou le magasin où vous avez acheté l'appareil pour obtenir des conseils sur le recyclage dans votre pays.
- D** Für elektrische Artikel, die in der europäischen Gemeinschaft verkauft werden.
Am Ende der Nutzungsdauer sollte das Gerät nicht im regulären Hausmüll entsorgt werden.
Bitte einer Recycling-Sammelstelle zuführen.
Informationen über geeignete Recycling-Acceptancestellen erhalten Sie bei Ihrer Stadt- bzw. Ortsverwaltung.
- E** Para productos eléctricos vendidos en la Comunidad Europea.
Al final de su vida útil los productos eléctricos no deberán desecharse con el resto de residuos domésticos.
Recíclelos en las instalaciones destinadas para ello.
Infórmese sobre consejos de reciclaje en su tienda habitual o consulte a las autoridades locales de su país.
- NL** Voor elektrische producten verkocht in de Europese Gemeenschap.
Op het einde van zijn levensduur mag een elektrisch product niet worden meegegeven met het gewone huisvuil.
Laat het product recycleren als deze mogelijkheid voorzien is.
Vraag bij uw lokale overheid of in uw winkel waar u daarvoor terecht kunt.
- P** Para produtos eléctricos vendidos na Comunidade Europeia.
Quando os produtos eléctricos atingirem o final da sua vida útil, não devem ser eliminados juntamente com o lixo doméstico.
Faça a reciclagem nos locais apropriados.
Contacte as autoridades locais ou o revendedor para saber como efectuar a reciclagem no seu país.
- I** Per gli elettrodomestici venduti all'interno della Comunità europea.
Al termine della vita utile, non smaltire l'elettrodomestico nei rifiuti domestici.
Riciclarlo laddove esistano le strutture.
Verificare con la Locale Autorità o con il dettagliante in merito alle possibilità di riciclaggio nel proprio paese.
- DK** Angående elektriske produkter, der sælges inden for EU.
Når det elektriske produkt har nået enden af sin levetid, må det ikke bortkastes sammen med husholdningsaffaldet.
Det bedes genbrugs, hvor der er faciliteter hertil.
Bed de lokale myndigheder eller forhandleren om råd om genbrug i dit land.
- S** Gäller elektriska produkter som säljs inom Europeiska Unionen.
När elektriska produkter inte längre kan användas ska de inte kastas med vanliga hushållsoppor.
Lämna dem till återvinning där det finns möjlighet.
Kontakta lokala myndigheter eller försäljningsstället och kontrollera vad som gäller för återvinning i ditt land.
- PL** Dla produktów elektrycznych sprzedawanych na terenie Wspólnoty Europejskiej.
Po zakończeniu okresu używalności produktów elektrycznych, nie należy ich wyrzucać wraz z odpadkami pochodzącymi z gospodarstwa domowego.
Jeżeli istnieją odpowiednie zakłady zajmujące się utylizacją, produkty należy poddać recyklingowi.
W celu uzyskania porady na temat recyklingu w Twoim kraju zwróć się do miejscowych władz lub lokalnego sprzedawcy.
- CZ** Pro elektrické výrobky prodávané v Evropském společenství.
Elektrické výrobky se po skončení životnosti nesmí vyhazovat do domovního odpadu.
Nechte je recyklovat v příslušných zařízeních.
Informace o recyklaci ve vaší zemi si zjistíte od místních úřadů nebo prodejce.

GB

F

D

E

NL

P

I

DK

S

PL

RU

CZ

TR

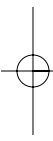
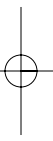
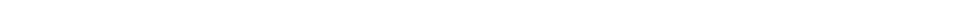

morphy richards®

KT43690MEE Rev 6 10/09

www.morphyrichards.com



app

Aust

