

Billi Quadra Plus

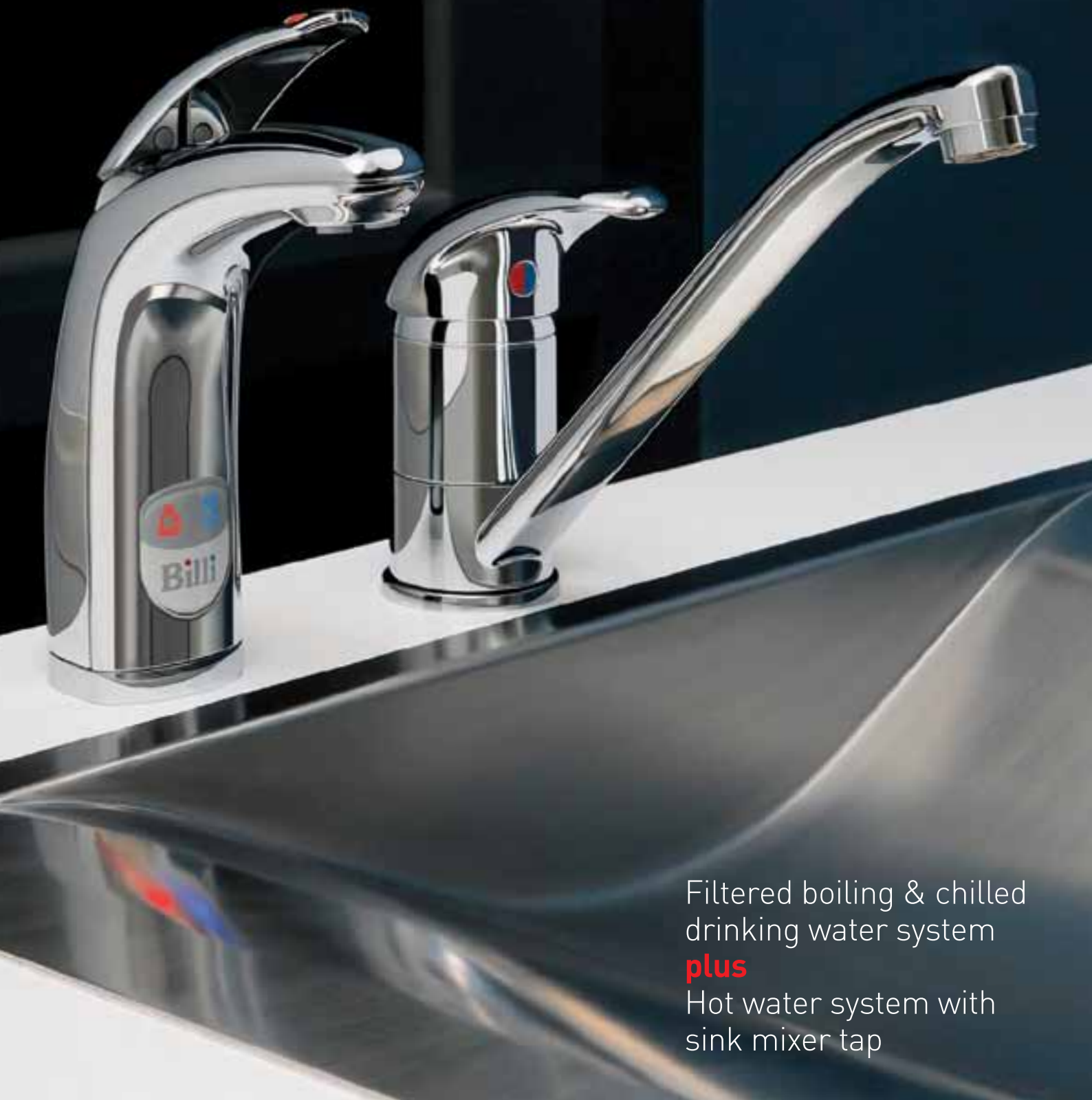

Filtered boiling & chilled
drinking water system
plus
Hot water system with
sink mixer tap



Billi **Quadra Plus**... not only provides filtered boiling and chilled drinking water, it also functions as your hot water service

new Billi Quadra Plus – space-saving superiority

The revolutionary, space-saving Billi **Quadra Plus** not only dispenses filtered boiling and sparkling clean chilled drinking water – it also provides a separate Sink Mixer Tap to deliver hot or cold water, either separately or mixed. The generous supply of instant hot water (up to 50°C) removes the need for other appliances such as bulky under-bench hot water cylinders or energy-wasting instant hot water systems. Imagine the design flexibility this new feature affords you. No longer do you need to provide space and extra connections for a separate hot water service in kitchens, lunchrooms or breakout areas.

new Energy-saving features

- Billi's patented* **Thermodynamic Heat-Cell** technology absorbs an extraordinary amount of heat energy generated during the chilling cycle and uses this normally wasted heat energy to preheat the boiling water. **Quadra Plus** extends this technology to the hot water supply, achieving even greater power savings to further Billi's Ecologically Sustainable Development (ESD) initiatives.
- A 7-day energy saving time switch ensures the **Quadra Plus** only operates when you need it, significantly reducing running costs by eliminating unnecessary out-of-hours power consumption. Cold water remains available at all times.
- An energy-saving standby mode may be preset to activate after a period of non-use, during which the hot water temperature is lowered to conserve power. At the touch of either Dual-Temp Dispenser lever, the **Quadra Plus** resumes its normal operating mode.
- High-performance insulating materials further enhance the **Quadra Plus**'s energy efficiency. Moulded expanded polypropylene provides a high thermal R-value rating, reducing heat losses and thereby conserving power.

Water Cooled or new Air Cooled option

Water-cooled Quadra Plus has evolved from Billi's original innovative concept. Extremely quiet in operation, it requires no cupboard ventilation, cooling fan or coil. Additionally, the new Heat-Cell technology ensures that water usage is absolutely minimal, reflecting Billi's responsible water management.

Air-cooled Quadra Plus may be selected as an option. Requiring no cooling water to be released and generating far less heat than other air-cooled systems, these units can be linked to a thermostat controlled booster fan vent to aid the efficient operation of the fan-coil unit.

new Intelligence you can see

The Billi **Quadra Plus** features an LCD display panel that monitors its operation. Should a difficulty arise, a help button activates an assistance menu to guide the user through the problem. Programming is simple and important usage data is easily accessed. Instructions such as 'How to change filters' are shown as step-by-step moving graphic images. Billi's Daylight Saving Mode also easily adjusts the timeclock at the beginning and end of daylight saving.

new Billi Font – water where you want it

The stainless steel Billi Font harmonises perfectly with the new **Quadra Plus** Dual-Temp Dispenser and allows installation away from the traditional sink area. Designers have greater flexibility as the Billi Font can be easily installed where it is most needed, offsetting the Dual-Temp Dispenser from the underbench unit and mixer tap components.

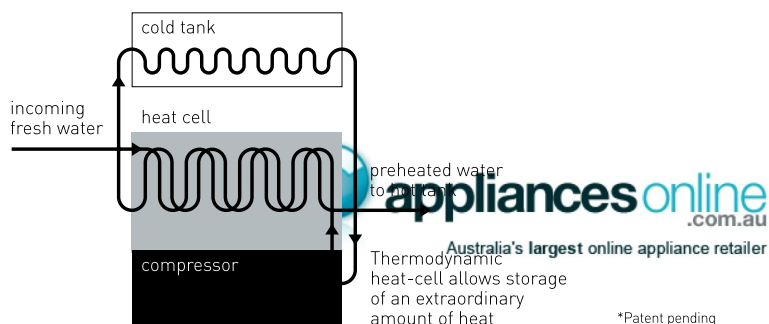

Schematic diagram of Billi's Thermodynamic Heat-Cell technology



Innovative, space-saving Billi **Quadra Plus**... a pleasure to use

Elegant and functional dispensers

The **Quadra Plus** features two elegantly styled and ergonomically designed dispensers – the Billi Dual-Temp boiling and chilled water dispenser, complemented by the Billi Sink Mixer Tap. Cast from solid metal alloy, these dispensers are designed to withstand the rigours of high-use environments. The Dual-Temp Dispenser features two position-sensitive, colour-coded levers, allowing control of the boiling water flow rate. Levers can be pressed for single cup delivery or lifted for continuous flow and a swivel action allows the dispenser to be swung out of the way if more sink space is required. Whilst conveying a simple statement of design co-ordination, the Sink Mixer Tap is an integral component of the **Quadra Plus** function, achieving exceptional results in water saving initiatives.

User safety

User safety is paramount in the design of the **Quadra Plus** Dual-Temp Dispenser. Its heat-insulated body and concealed childproof safety-switch ensure a high level of user protection. Water flow is electronically varied, slowing momentarily as water first enters the cup for smooth, splash-free delivery. A must for childcare and aged care facilities, its design accords with Australian Standards for ease of use for persons with a disability.

new Advanced filtration for great tasting water

Sparkling clean, filtered water is nature's most refreshing drink and the **Quadra Plus** features an all-new, advanced boiling and chilled water filtration system that provides sparkling fresh water. Dual filters ensure maximum effectiveness and extended service life. Sealed disposable cartridges are hygienic and convenient.

new Easy-change replacement filters

Replacing the all-new **Quadra Plus** filter cartridges couldn't be simpler. Flashing amber dispenser icons indicate when replacement is due. The patented* swing-change filters simply swing forward and slide off. Fitting the new filters is just as easy... slide filters in and swing back. Cartridges lock into place and a flushing cycle begins automatically.

Leakguard detection system

For peace of mind, the **Quadra Plus** features a watertight base tray and water detection system. Should leakage ever occur, water supply to the system will be instantly shut off.

Commitment to quality

Reliability has been engineered into the Billi **Quadra Plus** as an imperative in the design process. Proven, high quality materials have been carefully selected for maximum dependability and longevity. Manufactured to strict quality standards, the **Quadra Plus** is built for performance over the long term. **Quadra Plus**'s generous warranty is a reflection of Billi's long-term commitment to quality.

Options and accessories

- **Finishes:** Standard finish for the **Quadra Plus** Dual-Temp Dispenser and Sink Mixer Tap is Bright Chrome. Optional finishes include Satin Chrome and Black Sapphire Chrome.
- **Billi Font:** Allows the **Quadra Plus** Dual-Temp Dispenser to be located away from sink areas. Finished in polished Stainless Steel.
- **Dispenser Riser:** 65mm dispenser extension – supplied standard with the Billi Font.
- **Sink Mixer Disabled Lever:** Replaces standard Sink Mixer lever.
- **Tubing Extension Kit:** Allows the dispenser to be offset from the underbench unit.
- **Vent Kit for AC^ units:** Standard or booster-fan versions are available.

Specifications and guide to model selection

Billi Quadra Plus model	50° hot water capacity litres	50° hot water delivery litres per hour**	boiling water delivery cups per hour	chilled water delivery cups per hour	heating element kW	current draw amps	height mm	width mm	depth mm
Quadra Plus 5	7	25	100	150	1.5	8	340	315	465
Quadra Plus 5 AC^	7	25	100	150	1.5	8	340	315	510
Quadra Plus 9	9	40	180	150	2.2	10	340	315	465
Quadra Plus 9 AC^	9	40	180	150	2.2	10	340	315	510
Quadra Plus 15	15	65	250	150	3.4	15	340	315	465
Quadra Plus 15 AC^	15	65	250	150	3.4	15	340	315	510

1 cup = 170ml, ^AC signifies Air-Cooled model, *Patent pending.

**A reserve of boiling water is still available after hot water is fully drawn



Space-saving Billi **Quadra Plus**... easy to install

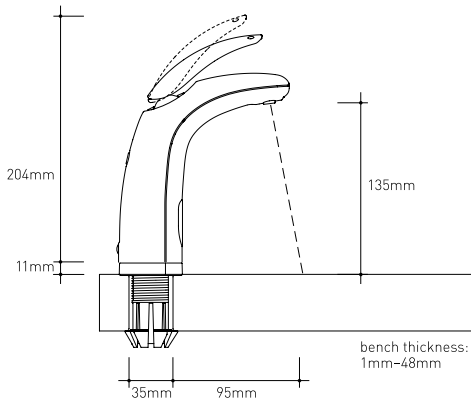

Billi Dual-Temp Dispenser dimensions

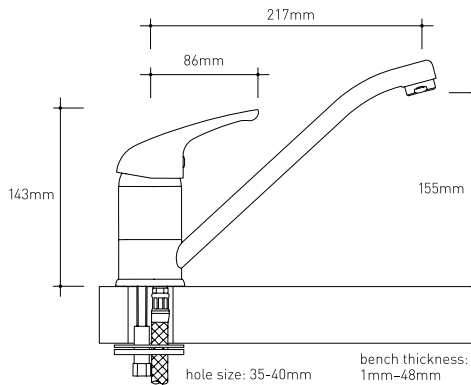

Billi Sink Mixer Tap dimensions

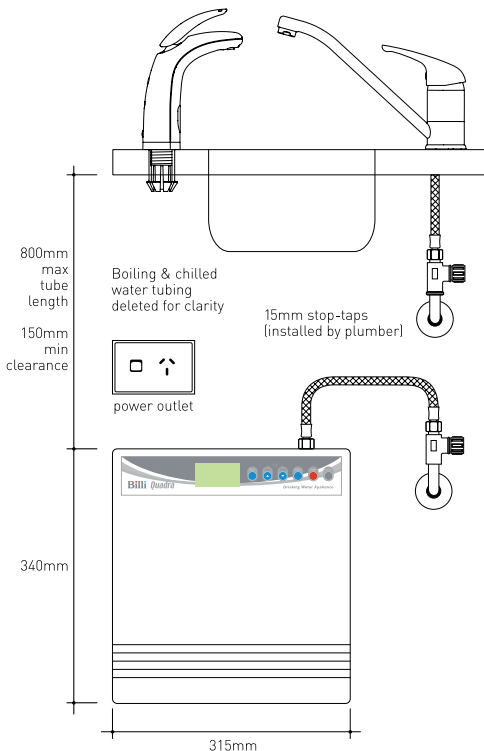

Preferred installation layout

Minimum cupboard dimensions:
Water-cooled unit: 475mm depth x 335mm width
Air-cooled unit: 520mm depth x 365mm width

new Easy installation

The new Billi **Quadra Plus** Dual-Temp Dispenser features a unique patented* dispenser top-mounting system, making it a plumber's dream to install. The 'snap-fit' base is secured into the mounting hole, pipework is fed through from the top and the dispenser securely clips into place.

Accessories included

The Billi **Quadra Plus** is supplied with all the tubing and fittings required for installation. A 450mm flexible braided steel hose with 15mm (1/2") female nut fittings is supplied for connection direct to the stop tap. Two 350mm flexible braided steel hoses with 15mm (1/2") female nut fittings are supplied for connection to the Sink Mixer Tap. A pressure regulator and dual-check backflow prevention device is built into the unit. No additional pressure reducing valve should be fitted.

Water supply

Two 15mm (1/2") stop-taps with male threads – one cold water supply to **Quadra Plus** and one cold water supply to the Sink Mixer Tap – should be installed in an easily accessible position. Water supply must be microbiologically safe to drink, with a minimum dynamic water pressure of 250kPa.

Power supply

The Billi **Quadra Plus 5** & **Quadra Plus 9** models require a standard 10 Amp power outlet and the **Quadra Plus 15** models require a standard 15 Amp power outlet in the cupboard area where the unit is to be installed. All models are supplied with a 1 metre flex cord and plug.

Replacement filters

Periodic replacement of filter cartridges is necessary to maintain water quality. Genuine replacement Billi filter cartridges are available from authorised Billi agents. Cartridges are also available to suit the needs of different water supply areas. Optional sub micron filters are NSF certified to safely remove health threatening giardia and cryptosporidium.

Warranty

The Billi **Quadra Plus** stainless steel boiling water tank is covered by a **5 year pro rata warranty**. All other components are covered by a **12 month warranty**. Filter cartridges are not covered by warranty, as water conditions and usage vary.

Certifications

Every Billi drinking water appliance is manufactured under a certified quality control system. The Billi **Quadra Plus** has been tested and complies with all required standards including: 4 star WELS rating; Watermark Licence Number 21525; Tested to AS3498 and AS/NZS4020; AS/NZS ISO 9001 Certificate Number QEC 11627; C-Tick approved; Complies with AS1428 Requirements for Access for the Disabled.



Billi Pty Ltd

42 Lucknow Crescent Thomastown
Victoria 3074 Australia
Telephone +61 3 9469 0400
Facsimile +61 3 9469 0499
Website www.billi.com.au

Designed and manufactured in Australia

As Billi Pty Ltd has a policy of continual improvement, all details are subject to change without notice. All goods are sold subject to our published terms and conditions.

Billi is a registered Trade Mark. Quadra Plus is a Trade Mark. QPlus 0609.

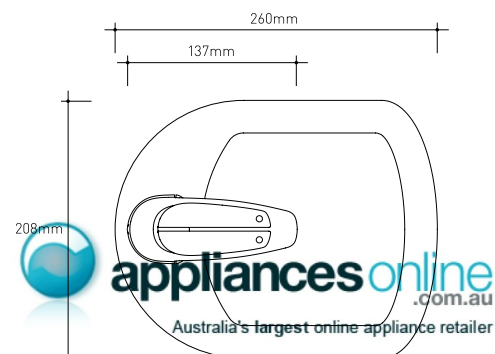

Billi Font benchtop layout

*Patent pending