

GAS
600mm

ACD6SG1



Colour:	Stainless Steel
Model:	ACD6SG1 60cm Gas Cooktop <i>as pictured</i>
Dimensions:	580mm (L) x 510mm (B) x 90mm (D)
Cut out Dimensions:	555 (L) x 473 x (B)
Features:	Front Left Burner -Triple/Wok Burner 1 x 14.0 Mj/h Front Right - Auxiliary Burner 1 x 4.5 Mj/h Back Left & Right Burners Semi Rapid Burners 2 x 6.0 Mj/h Cast Iron Pan Supports One Piece Stainless Steel Hob Electric Ignition Front Position Control Knobs
Natural Gas:	30.5 Mj/h
Propane:	29.5 0Mj/h
Power:	220-240 volt / 50Hz 10amp 3 pin plug
Warranty	2 years Parts and Labour
Customer Service:	Our Nationwide Service Team can be contacted on our Toll Free Customer Service Number 1800 805 300 or by logging on to customersupport.integratedappliancegroup.com.au



www.arcappliances.com.au

COOKTOPS



GAS
600mm

ACD6SG1

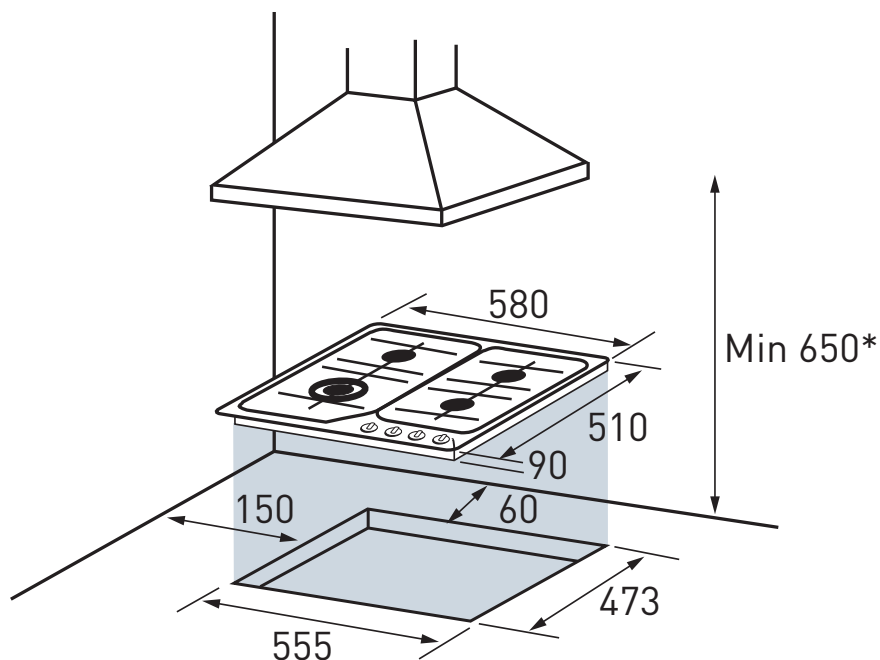

* Above cooktop highest point

All Arc Appliances have a complete 2-Year Warranty on parts and labour. Our Toll Free Customer Service Number 1800 805 300 provides helpful advice and ready access to a nationwide service team.



EXTENDED WARRANTY

All Arc electric or gas appliances for your kitchen are now available with an OPTIONAL full 5 year Parts and Labour Warranty.

Visit www.arcappliances.com.au or call our Toll Free Customer Service Number 1800 805 300 for details.

www.arcappliances.com.au

SPECIALIST APPLIANCE SUPPLIER TO THE KITCHEN INDUSTRY