

# Billi™

HOME

Designed with you in mind.  
Instant filtered water systems  
for your home.



# Introducing Billi Home.

---

## Designed with you in mind.

The Billi Home range provides you with the ultimate in drinking water appliances. Imagine the convenience of an instant supply of refreshing clean filtered water – boiling and chilled.

### The Billi story

At Billi, we design and manufacture a range of energy-efficient filtered water systems that offer our customers the very best in innovation, superior performance and reliability.

For more than 20 years, we have maintained a commitment to excellence and quality that is second to none. Our award-winning Billi filtered water systems are preferred by Australian designers and architects for their elegant styling and space-saving design.

The first Billi water system was launched in the early 1990s and was instantly recognised as the premium product of choice because of its high functionality, energy efficiency and space-saving design. From that first product, our range has grown to include a full complement of commercial and domestic systems now available throughout the world.

Today, we continue to innovate. Our designs keep pace with modern building techniques, contemporary interior concepts and changing lifestyle choices. And importantly, all our products continue to incorporate improved eco-technology features.

From design to manufacture, distribution and installation, every Billi water system is created to last. We offer premium aftersales assistance and product support, ensuring that our valued relationship with our customers doesn't end at purchase.

Billi is fully Australian-owned and all Billi products are Australian-made.



## Contents

Convenience, functionality and style	4
Premium filtration	6
Dual temp dispenser options	8
Instant boiling, chilled and ambient filtered water systems	9
Slimline dispenser options	10
Instant chilled and filtered water systems	11
Warranty and certifications	14
Installation specifications	15

Convenience,  
functionality and style.

---



---

**—Instant boiling water**

With the innovative Billi electronic temperature regulation system and precise temperature monitoring functions, your hot water will be delivered as close to boiling point as possible. You will never experience temperature drop off even during high use periods.

**—Water perfectly chilled**

Enjoy the convenience of being able to vary your chilled water temperature to suit your taste and the seasons. A simple adjustable control allows you to raise the temperature to 15°C or lower it to 6°C for your perfectly chilled, refreshing drinks, with your desired temperature being quickly reached and maintained.

**—Save on space**

With a focus on space-saving, the compact Billi Home systems have been designed to simply integrate into any storage module design. Less than half the size of other units on the market, it fits easily within a standard cupboard compartment and allows you to make the most of the available area.

**—Safety first**

Safety is paramount in the design of the dual temperature dispenser. With its heat-insulated body and concealed childproof safety-switch, you can be sure of a high level of user protection. Billi's Splash Free™ boiling water delivery means that flow is electronically varied, slowing momentarily to eliminate splashing as the water first enters your cup.

**—Leakguard detection system**

With the B-6000, B-5000, B-4000 and B-3000, there is no need to worry about water leakages. To ensure your peace of mind, a watertight base tray and water detection system have been incorporated into the system's design. If a water leakage should ever occur, the water supply is instantly shut off.

**—No ventilation required**

Because they generate far less heat than other systems, Billi Home systems do not require cupboard ventilation or an external cooling fan. Instead, its design incorporates a unique cooling system that further enhances energy efficiency and removes the need for cabinet alterations.

**—Disability conscious design**

Designed for all users, the dispenser's lever operations meet current Australian Standards relating to access for people with a disability.

**—Functional style**

You will find the elegantly styled and ergonomically designed Billi dispenser a pleasure to use. Colour-coded levers are position-sensitive, allowing control of boiling water flow rate. You simply press a lever for a single cup or lift for continuous flow. A swivel action allows you to swing the dispenser out of the way if you need more sink space. Cast from solid metal alloy, the dispenser is designed to withstand the rigours of high-use environments.

**—Energy efficient**

There is no need to compromise your lifestyle to lessen your carbon footprint. With the highly energy-efficient Billi Home systems, you can reduce your environmental impact and save on power bills. New Eco Intelligence™ software allows the B-5000 and B-4000 to operate only when required. Not only that, the system monitors your daily usage patterns and even recognizes evening and weekend changes in routine to effectively minimise your energy consumption. Or you can select an energy saving standby mode on any Billi Home system that will activate after a preset period of non-use.

**—High performance insulation**

Superior insulation is critical to the sustainability performance of any integrated boiling system. Designed with environmental factors in mind, the B-5000 and B-4000 utilise Billi's unique Thermostore™ technology and sophisticated insulating materials to operate at a level of efficiency which exceeds 50 times that of traditional hot water tanks.

**—Flexible font positioning**

Combining design flexibility with supreme functionality, the Billi Font can be easily installed wherever you choose, whether in the sink area or elsewhere – maximising the way you utilise your space. And with its classic simplicity, the Billi Font will coordinate with your other design features and appliances.

# Premium filtration.



990402 5 Micron replacement filter



990355 Sub Micron replacement filter



990356 Premium Sub Micron replacement filter

## —High-tech filtration system

Certified by global public safety agency NSF International, Billi's premium filters ensure that health threatening pollutants and impurities such as sediment, chemicals, heavy metals, chlorine and pesticides are safely removed leaving you with refreshingly clean drinking water, every time.

## —Replacement filters

Periodic replacement of filter cartridges is necessary to maintain water quality. Genuine replacement Billi filter cartridges are available online at [www.billihome.com.au](http://www.billihome.com.au) and from your local approved supplier. Cartridges are also available to suit the needs of different water supply areas.

## —Easy change replacement filter

Replacing your filter cartridge is simple. Flashing amber dispenser icons indicate when replacement is due. The swing-change filter simply swings forward and slides off. Fitting the new filter is just as easy – simply slide the filter in and swing it back. The cartridge locks into place.

## Filter options and product codes

Specifications	5 Micron	Sub Micron (standard with all systems)	Premium Sub Micron
Part number	990402	990355	990356
Suitable for:	All Billi Home Systems	All Billi Home Systems	All Billi Home Systems
Micron Rating	5	0.7	0.2
Capacity - Litres	8,700	8,450	8,350
Unit Flow Rate - Lpm	2.5	2.5	2.5
NSF42 certified	Yes	Yes	Yes
NSF53 certified	No	Yes	Yes
Retains fluoride	Yes	Yes	No

Good design is making  
something intelligible and  
memorable.  
Great design is making  
something memorable  
and meaningful.

Dieter Rams



# Dual temp dispenser options.

---



Optional brushed finish



Optional black finish

—Dispenser finishes  
Standard finish for the dispenser and font is bright chrome. Optional finishes include brushed and black



# Instant boiling, chilled and ambient filtered water systems.

## B-6000

### Instant boiling and chilled filtered water system

The flagship of our Billi Home range, the B-6000 is perfect for entertaining. It's space-saving efficiency and elegant, functional style are designed for high use and meet green building design principles, providing you with the ultimate in environmentally sensitive appliances.

#### —Specifications

Product Code	—916000
Initial Delivery Cups	—20
Boiling Water Delivery (Cups Per Hour)	—100
Chilled Water Delivery (Cups Per Hour)	—100
Heating Element (kw)	—2.4
Total Current Draw (amps)	—10
Height (mm)	—340mm
Width (mm)	—315mm
Depth (mm)	—365mm



Cupboard space saving - B-6000

## B-5000

### Instant boiling and chilled filtered water system

The most popular of our Billi Home range, the B-5000 is perfect for almost any household. Operating only when you need it, the B-5000 incorporates eco-intelligence software to eliminate unnecessary power consumption. It also complies with green building design guidelines, providing you with the ultimate in environmentally sensitive appliances.

#### —Specifications

Product Code	—915000
Initial Delivery Cups	—10
Boiling Water Delivery (Cups Per Hour)	—60
Chilled Water Delivery (Cups Per Hour)	—60
Heating Element (kw)	—1.5
Total Current Draw (amps)	—10
Height (mm)	—340mm
Width (mm)	—180mm
Depth (mm)	—500mm



Cupboard space saving - B-5000

## B-4000

### Instant boiling and ambient filtered water system

The petite Billi B-4000, the most space-saving of all the Billi drinking water systems, allows you to keep control of your cupboard while enjoying the convenience of instant boiling and an unlimited supply of ambient filtered water whenever you want it.

#### —Specifications

Product Code	—914000
Initial Delivery Cups	—10
Boiling Water Delivery (Cups Per Hour)	—60
Heating Element (kw)	—1.5
Total Current Draw (amps)	—10
Height (mm)	—340mm
Width (mm)	—180mm
Depth (mm)	—360mm



Cupboard space saving - B-4000

# Slimline dispenser options.



Optional brushed finish



Optional black finish

## —Optional Slimline Dispensers

A choice of square or rounded slimline tap styles gives you the perfect opportunity to match it with surrounding design elements

## —Dispenser finishes

Standard finish for the dispenser and font is bright chrome. Optional finishes include brushed and black

# Instant chilled and filtered water systems.

## B-3000 Instant chilled filtered water system

Vary the temperature of your chilled filtered water to suit the seasons by using an easily adjustable control. With a large chilling capacity, the B-3000 is whisper quiet, vibration free and completely unobtrusive. Its energy efficient design ensures minimal running costs.

### —Specifications

Product Code	—913000
Initial Delivery Cups	—10
Chilled Water Delivery (Cups Per Hour)	—60
Heating Element (kw)	—1.5
Total Current Draw (amps)	—10
Height (mm)	—340mm
Width (mm)	—180mm
Depth (mm)	—460mm

## B-1000 Instant filtered water system

Enjoy refreshing clean filtered water in your home all day, every day with Billi sub micron filtration. The B-1000 filter module fits comfortably in a standard shelf compartment, allowing you maximum usable cupboard space.

### —Specifications

Product Code	—911000
Height (mm)	—320mm
Width (mm)	—140mm
Depth (mm)	—130mm



Optional square profile slimline dispenser



Cupboard space saving - B-3000



Cupboard space saving B-1000

Life's too short to stand  
around waiting for  
a kettle to boil.





# Warranty and certifications.

---

## —Standard warranty

All components of the systems are covered by a 24-month\* warranty. Filter cartridges are a consumable and are not covered by warranty, as water conditions and usage vary.

## —Extended warranty

Further extended warranty, maintenance and filter contracts are available. For further information call Billi's national service centre on 1800 812 321.

\* 24-month warranty dependant on installation by Billi service technician.

## —Commitment to quality

A strong commitment to quality is as important to Billi as style, function and innovation. Recognising the importance of reliability to customers, all Billi water systems are manufactured to strict quality standards and built to last. Every system is designed to provide the highest possible standards of efficiency and energy savings.

## —Certifications

Every Billi drinking water appliance is manufactured under a certified quality control system. They have been tested and comply with all required standards. B-6000, B-5000 and B-4000 comply to; Watermark Licence Number 21525; tested to AS3498 and AS/ NZS4020. B-3000 and B-1000 comply to: Watermark Licence Number 21882. Tested to ATS 5200.105:2005; All Billi Home systems are also tested to: Victorian Electrical Safety Act 1998 Approval Number CS100600V; AS/NZS ISO 9002 Certificate Number QEC11627; C-Tick approved.



# Installation specifications.

## —Easy installation

The B-6000, B-5000 and B-4000 dispensers feature a unique top mounting system, making it simple to install. There is no need to reach up behind sink bowls to secure clamps or tubes - the 'snap-fit' base is secured into the mounting hole, pipework is fed through from the top and the dispenser securely clips into place. The B-3000 and B-1000 installation is just as simple. Colour coded flexible tubing and easy connect fittings ensure a rapid and trouble-free install.

## —Water supply

A single 15mm (1/2") stop-tap with a male thread should be installed in an easily accessible position. The water supply must be microbiologically safe to drink, with a minimum dynamic water pressure of 250kPa.

## —Power supply

Billi Home B-6000, B-5000, B-4000 and B-3000 systems require a standard 10 amp power outlet. It is supplied with a 1 metre flex cord and plug. B-1000 systems do not require a power supply.

## —Dispenser riser

70mm dispenser extension – supplied standard with the Billi dual temp Font. Optional finishes include brushed and black.

## —Extension kit

Available for installations where the dispenser needs to be offset from the underbench unit.

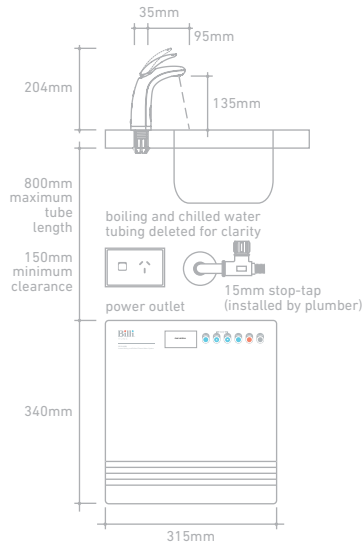

Tap hole size 35mm  
**B-6000 Preferred installation layout**

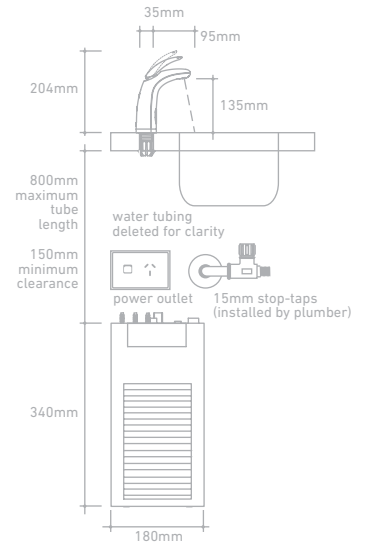

Tap hole size 35mm  
**B-5000 and B-4000 Preferred installation layout**

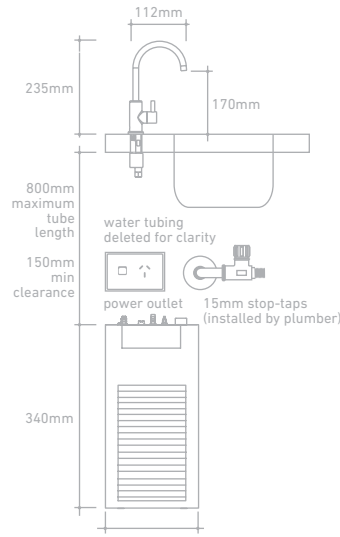

Tap hole size 22mm  
**B-3000 Preferred installation layout**

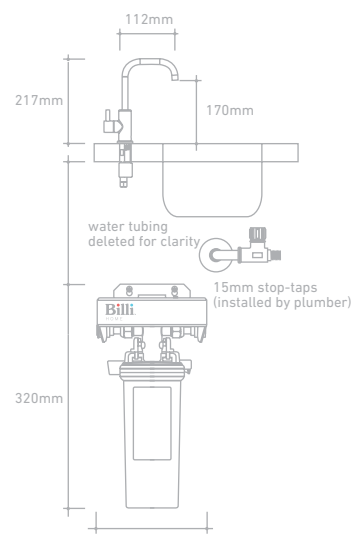

Tap hole size 22mm  
**B-1000 Preferred installation layout**

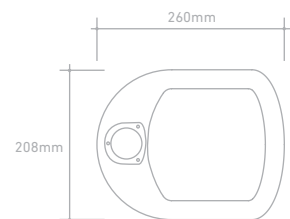

**Billi font benchtop layout**



---

Billi Pty Ltd  
42 Lucknow Crescent, Thomastown  
Victoria 3074 Australia

Telephone +61 3 9469 0400  
Facsimile +61 3 9469 0499

[www.billihome.com.au](http://www.billihome.com.au)

Designed and manufactured in Australia.

As Billi Pty Ltd has a policy of continual improvement, all details are subject to change without notice. All goods are sold subject to our published terms and conditions. Billi is a registered trademark. 1011