

BLANCO



Performance First

Instructions for the Use and Care and Installation of

BFS60CX

BFS60NX

BFS60NXFF

BFS60WX

BFS60WXFF

Freestanding Multifunction Ovens.

Dear customer,

You will find that the clean lines and modern look of your **Blanco** oven blends in perfectly with your kitchen décor. It is easy to use and performs to a high standard.

Blanco also makes a range of products that will enhance your kitchen – such as cook tops, rangehoods, dishwashers, microwaves, sinks and taps. There are models to complement your new Blanco oven. Blanco now has a range of laundry products to choose from.

Of course, we make every effort to ensure that our products meet all your requirements, and our Customer Relations Department is at your disposal, to answer all your questions and to listen to all your suggestions.

Please complete the warranty section of this manual and keep your receipt as proof of purchase. Retain all documents relating to the purchase of Blanco product.

Blanco is committed to providing increasingly efficient products that are easy to use, respect the environment and are attractive and reliable.

BLANCO

GENERAL WARNINGS

Read the following carefully to avoid an electric shock or fire.

It is most important that this instruction book should be retained with the appliance for future reference. Should the appliance be sold or transferred, always ensure that the book is left with the appliance in order that the new owner can get to know the functions of the appliance and the relevant warnings. These warnings are provided in the interest of safety. You **MUST** read them carefully before installing or using the appliance.

- The appliance is not intended for use by young children or infirmed persons without supervision.
- Young children should be supervised to ensure that they do not play with the appliance.
- **WARNING:** Ensure the appliance is switched off before replacing the lamp to avoid the possibility of electric shock.
- **WARNING** - In order to prevent accidental tipping of the appliance, for example by a child climbing onto the open oven door, the stabilizing means must be installed. Please refer to instructions for installation.
- **WARNING** - Accessible parts will become hot when in use. To avoid burns and scalds children should be kept away.
- Do not use a steam cleaner to clean a hob, oven or range.
- Do not spray aerosols in the vicinity of the appliance when it is in operation.
- Do not store or use flammable liquids or items in the vicinity of this appliance, eg aerosols.
- Accessible parts will become hot when in use. To avoid burns and scalds children should be kept away.
- Always turn the grill off immediately after use as fat left there may catch fire.
- Do not cover the insert with foil, as fat left there may catch fire.
- Always keep the grill dish clean as any fat left there may catch fire.
- Do not leave the grill on unattended.
- To avoid a fire, ensure that grill trays and fittings are always inserted into the appliance in accordance with the instructions.
- Switch the appliance off before removing the oven light glass for globe replacement.
- To avoid an accident, ensure that oven shelves and fittings are always inserted into the appliance in accordance with the instructions.
- Do not use the door as a shelf.
- Do not push down on the open oven door.
- Do not allow large cookware to overhang the hob onto the adjacent benchtop. This will cause scorching to the benchtop surface.
- An authorized person must install this appliance.
- Before using the appliance, ensure that all packing materials are removed from the appliance.
- In order to avoid any potential hazard, the installation instructions must be followed.
- Ensure that all specified vents, openings and airspaces are not blocked.
- Only authorized personnel should carry out servicing.
- Always ensure the appliance is switched off before cleaning or replacing parts.
- Always clean the appliance immediately after any food spillage.
- To maintain safe operation, it is recommended that the product be inspected every five years by an authorized service person.
- If the supply cord is damaged, it must be replaced by the manufacturer or its service agent or similarly qualified person in order to avoid a hazard.

Warning: Where this appliance is installed in marine craft or in caravans, it shall not be used as a space heater.

Warning: Never use the food-warmer drawer set at the bottom of the range to store flammable substances or matters that cannot withstand heat such as wood, paper, spray cans rags, etc.

2 INSTALLER'S GUIDE

2.1 COOKER INSTALLATION

The Manufacturer declines any and all responsibilities for damages to things or injuries to persons or animals deriving from incorrect installation or use of equipment.

The appliance has been certified by the Australian Gas Association and meets the requirements of AS4551/AG101 Domestic Gas Cooking Appliances.

This appliance shall be installed only by authorised personnel and in accordance with the manufacturer's installation instructions, local gas fitting regulations, municipal building codes, water supply regulations, electrical wiring regulations, AS 5601/AG 601 - Gas Installations and any other statutory regulations.

The gas and electricity conditions are indicated in labels near the gas / electricity inlets.

The materials used in the cabinet to house the oven must be able to withstand a temperatures of 90°C

Combustible materials, like curtains must be at the minimum distance of 500 mm

The furniture sided the cooker, if higher than the cooking plan, must be at a minimum distance of 150 mm from the side of the appliance - unless that surface is constructed of a suitable non-combustible material for the entire length of the cooking surface.

Any horizontal surface situated within 200mm from the edge of any hob burner must be a minimum of 10mm below the cooking surface or else comply with the above.

If the cooker is installed under a suspended element, this one must be placed at a minimum 700 mm of distance from the cooking plan.

The furniture over and sided the appliance must have a minimum clearance of 450 mm from the cooking surface.

Zero clearance is permitted on side and rear adjoining surfaces provided the surfaces are minimum 10mm below the hob.

Any rangehood above the cooker must be installed according to the manufacturer's instructions, with a minimum distance of 600 mm from the highest part of the hob to the rangehood.

The appliance must be installed in places with proper conditions relative to dimensions, ventilation and exhaust of combustion products.

This appliance is not designed to be connected to an exhaust combustion products device.

Ventilation must be in accordance with AS5601/AG 601 - *Gas Installations*. In general, the appliance should have adequate ventilation for complete combustion of gas, proper flueing and to maintain temperature of immediate surroundings within safe limits. It is recommended that a rangehood be fitted above the appliance and exhaust to the outside.

Before installing the cooker, remove the protective plastic sheathing covering some metal parts.

If the appliance is on a support, devices must be used to avoid sliding the appliance as damage may occur.

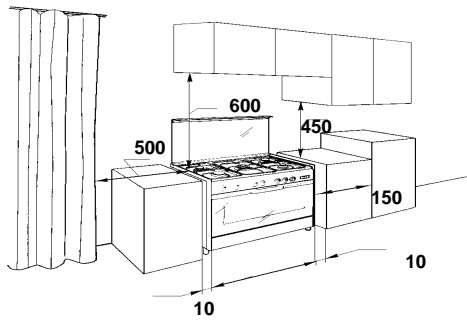

Anti – Tilt Device

The cooker is supplied with an anti-tilting chain to prevent accidental tilting of the cooker. The chain is to be restrained with a hook, which is to be fixed to the wall using a method that suits the wall material and restrains the weight of the cooker. The chain is a safety device and must be fitted to all cookers. Failure to fit the chain properly may cause personal burns injuries and damage to the gas pipe.

Important: After fixing the chain, ensure the chain is taut and appliance cannot tilt forward or sideways.

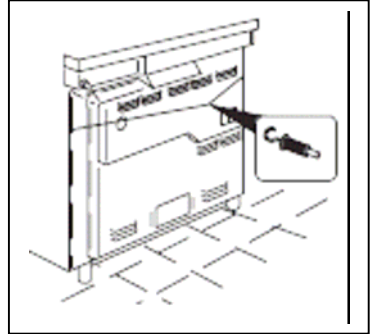

Important: For a situation where the appliance is between two cupboards and the anti tilt chain cannot be fitted please contact Blanco Technical Department for advice.

2.2 GAS CONNECTION

The cooker is provided with a label placed on the rear panel near the gas inlet, showing the type of gas and pressure for which the appliance has been originally adjusted.

Before connecting this appliance, check the data label to ensure that it matches the available gas type.

It may be necessary to convert the appliance to the appropriate gas type (see section 2.4).

Refer to your local gas authority for confirmation of the gas type, if in doubt.

The Gas Connection is male 1/2" BSP and is situated at the right hand rear of the appliance, 40mm from the side of the cooker and 555-570mm above floor level (depending on height of the adjustable legs).



This appliance is suitable for connection to Natural and Propane Gas. Refer to gas pressure shown on the data plate and in the table n° 1.

Never place a Propane gas bottle inside the building.

You may connect the appliance to a gas bottle fitted with a regulator, which will maintain a supply pressure of 2.75 kPa or a Propane Gas network, which supplies a pressure of 2.75 kPa to the appliance test point.

There are two ways to carry out the connection to the main gas line:

A. The cooker can be connected with rigid pipe as specified in AS5601 table 3.1.

B. The cooker can be connected with a Flexible Hose, which complies with AS/ANZ 1869 (AGA Approved), 10mm ID, class B or D, no more than 1.2m long and in accordance with AS5601 for a high level connection. The Hose should not be subjected to abrasion, kinking or permanent deformation and should be able to be inspected along its entire length. Unions compatible with the hose fittings must be used and connections tested for gas leaks. The fixed consumer-piping outlet should be at approximately the same height as the cooker connection point, pointing downwards and approximately 150mm to the side of the cooker. The hose should be clear of the floor when the cooker is in the installed position. The hose restraint chain supplied should be anchored to the wall so that the chain prevents strain on the hose connections when the cooker is pulled forward.

The gas supply must be connected with the Regulator supplied for natural gas installations, or Test Point Assembly supplied for Propane gas installations.

An isolation tap fitted in an easily accessible position is recommended.

Check that the gas pressure for Natural Gas is 1.00 kPa at the test point with the largest hotplate burner on maximum flame.

2.3 ELECTRIC CONNECTION

WARNING: ELECTRICAL WORK ON THIS APPLIANCE MUST ONLY BE DONE BY A QUALIFIED PERSON AUTHORISED BY THE LOCAL AUTHORITIES TO PERFORM THIS WORK. ELECTRICAL WORK DONE BY UNQUALIFIED PERSONS COULD RESULT IN A SAFETY HAZARD OR PROPERTY DAMAGE.

IMPORTANT: The appliance must be always connected to the ground, according to actual regulations by qualified personnel.

The earth connection conductor is green/ yellow.

In case of substitution, the section of the cables should not be less than is indicated in the table of technical characteristics, and concerning the quality; the cables must be types H05RRF.

According to the models, see table of technical characteristics, the alimention could be, 240 V ~, single-phase current (2+1 conductors) or 415V 2N ~, two-phase current (3+1 conductors), or three-phase current 415V 3N ~ (4+1 conductors).

A two-phase or three-phase current appliance could be transformed in single-phase current, if the electric installation is adequate.

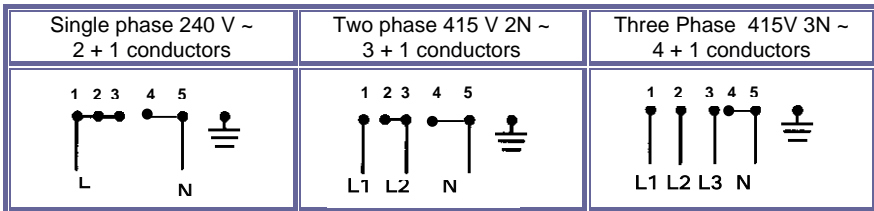

POWER CABLE CONNECTION

For a direct connection to the electric network is necessary to mount before the appliance an circuit breaker according to the electric charge.

Before connection to the electric network, check that the domestic system and the limiter valve can take the appliance load (see table of technical characteristics)

The Cable of alimention must be according with the technical characteristics.

The supply cable must be positioned that no point can reach a temperature 50°C higher than ambient temperature.

The producer is not responsible if the regulations are not respected.

The producer is not responsible for eventual direct or indirect damages owing to a wrong installation, regulations misunderstanding or standards in force not respected.

In the models BFS 60 NX FF (10 A) and BFS 60 WX (15 A) the plug must be like the figure.

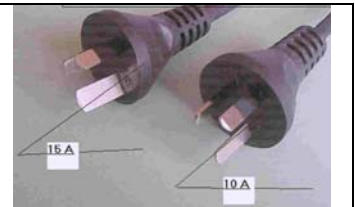

2.4 CONVERSION TO OTHER TYPE OF GAS

This operation must be executed always by qualified and authorised tradesperson.

This appliance has been designed to function with Propane or Natural gas.

This appliance is provided with a label on the rear panel, near the gas inlet, indicating the type of gas for which the cooker has been adjusted.

The gas types that the appliance is certified for installation are nominated on the data label, which is located on the inside of the storage compartment. Do not connect to any other gas type.

In order to convert from one type of gas to another, proceed as follows:

- 1 - Remove the pan supports from the hob, then remove the burner caps and burner head/skirts.
- 2 - Unscrew and remove the injectors, and replace them with those supplied corresponding to the gas available (see burner and injector table 1).
- 3 – Replace all burner component and the pan supports.
- 4 - After connecting the unit, check for gas leaks with soap and water solution. **NEVER USE A FLAME.**
- 5 - Place, near the inlet gas connection, a label indicating the type of gas for which the appliance is now prepared. "Appliance prepared for". Remove the old gas type Label.
- 6 - When converting from Natural Gas to Propane ensure that the NG regulator is removed and replaced with the Test Point Assembly. A gas regulator suitable for a supply pressure of 2.75kPa should be part of the gas tank supply and the test point pressure should be adjusted to 2.75kPa.

2.5 GAS TAPS/VALVES MAINTENANCE AND CLEANING

If the gas tap/valve is hard to turn, do not force it. It might need lubricating.

This operation must be executed always by qualified and authorised tradesperson.

To access the taps/valves, pull burner heads and remove the cooking top.

To lubricate the taps/valves, follow these instructions.

- With a screw-driver, remove the cover.
 - Pull the cone out of its housing.
 - Clean the cone with a dry lint-free cloth
 - Lubricate the cone carefully, with grease recommended (Molykote, Staburgs N32, Rocol HT, Optitemp HT2 EP), and take off the excess grease to avoid obstructing the gas passages.
 - Introduce the cone and the spring and screw the cover.
 - Turn the cone several times, to ensure it is not hard.
- Check for gas leaks, with the tap opened and closed. **NEVER USE A FLAME.**

BEFORE LEAVING.

Check all connections for gas leaks with soap and water. DO NOT use a naked flame for detecting leaks. Ignite all burners to ensure correct operation of gas valves, burners and ignition. Turn gas taps to low flame position and observe stability of the flame. When satisfied with the cooker, please instruct the user on the correct method of operation. In case the appliance fails to operate correctly after all checks have been carried out, please call TECHNICAL SERVICE.

3 USER'S GUIDE

3.1 HOW TO USE BURNERS FOR GAS COOKTOP MODELS

If you use the burners properly, it will maximise energy efficiency, thus saving energy.

The power of the burners (MJ/h) is shown in Table 1.

For optimum efficiency, you must choose pans according to the size of the burner see the table 3.

If the flame is wider than the pan then you are wasting energy.

The right position is indicated in this figure.

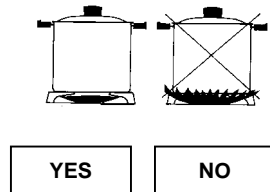

IMPORTANT (BFS60WXFF) :

In the models with triple ring burner, wok burner:

It is important to ensure that the burner caps are located correctly on the burner to ensure good burning.



IGNITION OF THE BURNERS

To ignite the burners proceed as follows:

- Press the knob. Selecting the burner to use, push the corresponding knob and turn it counter clockwise to the "full position", indicated by a large flame. 

- To reduce the power to turn the knob to the "low position", indicated by a small flame 

To switch off the burner, just turn the knob clockwise to the "off position", indicated by a black circle in the upper position of the panel 

COOKTOP BURNERS WITH FLAME FAILURE (BFS60NXFF; BFS60WXFF)

These models are fitted with flame failure.

If the gas supply is deficient or if the flame is extinguished accidentally, the gas circuit will be automatically closed.

To restart it is necessary to re-ignite the burner.

You will firstly need to verify that it is not a gas supply problem, wait at least one minute and repeat the lighting.

To ignite this type of burner it's necessary to depress and maintain pressure on the knob for 10 seconds.

After this time release the knob and the burner will then remain alight.

3.2 USING THE CERAN COOKTOP (BFS60CX)

Avoid any shocks with saucepans etc: The glass surface is highly resistant but not unbreakable.

Avoid rubbing with saucepans etc: as in time this will deteriorate the markings on the top of your ceramic hob.

Avoid using saucepans **with rough or dented bases**: They may hold and transport matter liable to stain or scratch the hob.

Any such faults, which are not the cause of breakdowns nor make the hob impossible to use, are not included in the guarantee.

Glass or porcelain saucepans may be used provided the base is flat.

The saucepan diameters should be according to the diameter of the work area.

Don't use saucepans with a smaller diameter to the work area see this figure :

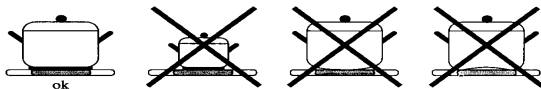

Cover the saucepan during cooking, to save energy.

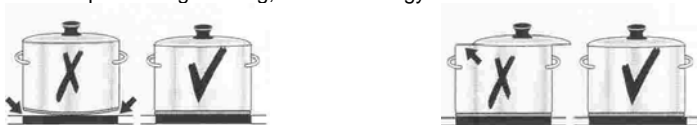

Always position saucepan before switching on the cooking zone.

How to use the work area :

Operation of the work area is realised by turning the knob through 3 positions, to the selected position (1 – minimum ; 3 – maximum).

For models with double heating. To activate the double zone, turn the knob clockwise until a click is heard. The area is then activated. To vary the control set the knob between 1 and 3.

To switch off the area, just turn the knob for the 0 position.

A light signal placed in the control panel indicates the working of a heating area.

A light signal placed in the front area of the glass indicates the “ residual heat “.

After being switched off, the cooking zones need some time to cool down. Look at the residual heat indicator.

Residual heat can be used for melting and keeping food warm

3.3 HOW TO USE THE MULTIFUNCTION OVEN

Various cooking options can be selected by the use of switching of different elements, and temperature that is controlled by a thermostat.

THERMOSTAT

For selecting and maintaining a temperature.

Oven light 

In this position only the light is in operation. The light stays on the other seven use positions.

Fan forced 

The circular heating element and fan come into operation and the heat is spread evenly to all shelf positions. Various types of food can be cooked on different shelves, naturally with the appropriate cooking times. The oven must be preheated before food is placed inside. Fan mode provides optimum results with: cakes large quantities of foods and cooking various dishes simultaneously.

To operate, select Fan Forced function along with the temperature.

Fan grill 

Use of the Grill Element and Fan. Use for grilling meats, vegetables and poultry. Preheat oven, place food on grill rack in baking tray and place in the middle of the oven. Other foods maybe cooked underneath whilst grilling.

Grill 

Grill Element - Use for toasting and melting cheese or browning. No longer than 5 minutes cooking time. To operate, select Full Grill Function along with the temperature.

Traditional 

The heat is provided from the top and bottom element. The oven must be preheated before food is placed inside. Static cooking provides optimum results with: cakes, pizzas, bread and for gentle slow cooking of casseroles.

Characteristics of static cooking: heat provided from above and below, cooking is possible only on middle shelf and should be centrally located in the oven.

Fan Assisted

The outside ring of the top element and the bottom element and fan come into operation and the heat is spread evenly to all shelf positions. Suitable for cooking pies and single layer baking. The oven must be preheated before food is placed inside. To operate, select Fan Assisted function along with the temperature.

The Oven door must be closed for all cooking functions

The accessible parts of the cooker can become hot, if the oven or the grill is in operation. Do not let children close to the appliance.

3.4 HOW TO USE THE ELECTRIC GRILL

The symbol “GRILL” indicates the functioning of the electric grill element.

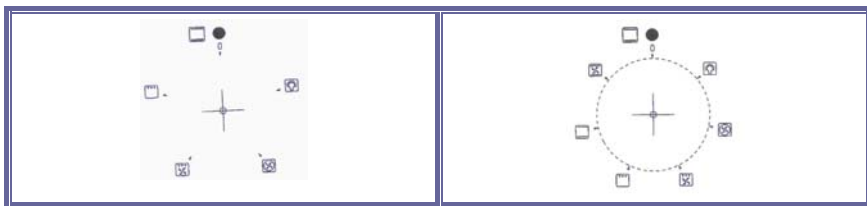

The electric power of the grill is indicated in table 3

Do not operate the grill with the door open.

3.5 OVEN LIGHT USE

With the light turned on you can watch the cooking through the oven glass window without opening the door for your convenience and economy.

To switch on the oven light turn the knob which is under the symbol and place the symbol in the upper position of the knob.

In some electric ovens the light turns on as soon as you turn the knob and stays alight until you turn off the oven.

3.6 MINUTE-COUNTER (BFS60NX; BFS60NXFF)

With the minute timer you can select time, from 0 to 120 minutes.

To use the minute-counter turn the knob one complete turn clockwise; then turn back counter clockwise and set to the required time.

When the pre-set time has elapsed, the bell rings.

The bell does not interrupt the working of any element of the cooker.

3.7 ELECTRONIC PROGRAMMER (MODELS BFS60CX; BFS60WX AND BFS60WXFF)

SETTING UP THE ACTUAL HOUR:

Once the electrical connection is made to the oven, the display blinks and shows 0.00.

Press keys (1) and (2) at the same time, then press keys (-) and (+) to set up the actual hour within 4 seconds; the oven remains in manual operation and no programming is necessary.

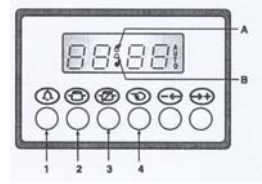

GENERAL REMARKS:

- Between 10.00 pm and 6.00 am the display intensity dims automatically.
- If not deactivated as per the following instructions, the acoustic signal is cut off after 2 minutes.
- Any programming described hereunder is activated after approx. 4 seconds from its setting up.
- 23 hours and 59 minutes is the maximum time allowed for programming the oven.
- If the supply voltage fails, all the programmed settings are erased. When the supply voltage returns, the display blinks and shows 0.00. Set up the actual hour and the programme again to reset the equipment operation.

SAFETY LOCK FOR CHILDREN

The programmer is provided with a safety lock which stops the cooking programming and consequently the oven operation;

Lock running:

- press both switches (1) (2) at same time for about 8 seconds
- the display shows "ON"; release the switches
- press switch (+); the display shows "OF" and the symbol "..key.."

Now the safety lock starts running and after about 5 seconds the display shows the current time and the symbol "..key.."

Lock deactivation:

- press both switches (1) (2) at same time for about 8 seconds
- the display shows "OF"; release the switches
- press switch (+); the display shows "ON"

Now the safety lock is deactivated and after about 5 seconds the display shows the current time.

3.8 RECOMMENDATION TO USE THE OVEN AND THE GRILL

The accessible parts of the cooker could be hot, if the oven or the grill is in operation. Do not let children close to the appliance.

Don't let children sit down or play with the oven door. Do not use the drop down door as a stool to reach cabinets above.



Pre-heat of the oven until it reaches the temperature, before placing food into the oven.

To minimize food splashes into the oven (which can sometimes produce smoke) deep baking dishes are recommended.

When the food is cooked directly on the shelf grid, you must place the baking dish below for collecting any residue.

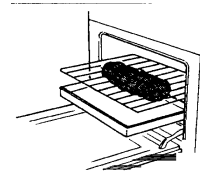

Never use the oven without the rubber seal

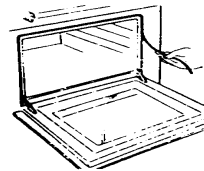

If the oven is operating - the oven door must be closed.

Avoid opening the door during the cooking, as temperature changes will spoil your cooking and increase energy consumption.

You can turn the oven off some minutes before the food is completely roasted as the residual temperature should be sufficient to complete the cooking.

4 INSTRUCTIONS FOR MAINTENANCE AND CLEANING

Warning: Servicing should be carried out only by authorised personnel.

Before maintenance or cleaning your cooker, switch off the circuit breaker, turn off the isolating gas valve or the gas mains and allow the cooker to cool down.

GENERAL CLEANING

Adequate maintenance and cleaning will prolong the life of the appliance, as well as ensure trouble-free service.

The cooker must be washed with warm water, using a damp sponge and ordinary detergent.

Never use scouring powder, steel wool or acids to clean the cooker.

The stainless steel parts should be washed, after the use, with water and dried with a soft cloth.

If the spots still persist, it may be necessary to use a non-abrasive detergent or warm water and vinegar.

The glass of the oven's door should be washed with warm water and a nylon pad soaked in ordinary detergent.

Avoid scrubbing the front panel, because this will erase the designs stencilled over each knob.

The enamelled grids of the hob can be washed in the dishwasher.

The cooker not must be cleaned with vapour equipments (eg. steam cleaners).

To maintain the characteristics of brightness of the enamelled parts it is necessary to clean the oven after each cooking. Once the oven is cold, you will be able to remove the fat deposits by means of a sponge or a cloth damp with warm soapy water. Never use abrasive cloths or sponges that could irreparably damage the enamel. After use, rinse the parts in stainless steel thoroughly and dry them with a soft cloth. In case of a persistent stain, use non-abrasive cleaning agents or some warm water and vinegar. Clean the door glass only with warm water, avoiding the use of rough cloths.

After removing the trivets for cleaning check that the rubber feet are still located in the feet of the trivet before replacing the trivet back into position on the hob.

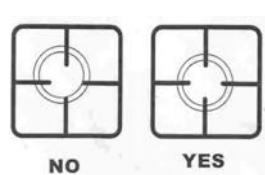

Laterals Grids

The laterals grids can be removed when cleaning the oven.

After cleaning relocate the grids like this :

- 1- Insert grid pins on the holes A located at the back panel of The oven.
- 2 - Insert grid pins on the holes B located at the lateral panels of the oven.
- 3 - Reverse this operation to remove the grids

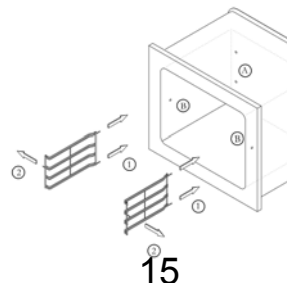

CLEANING CERAN COOKTOP (BFS60CX)

After use, once the cooker has cooled down, clean thoroughly as even small amounts of dirt can become impossible to remove when re-heated.

Do not use abrasive pads, sponges or powders to clean, as these products can scratch the surface of the glass.

Small amounts of dirt can be removed using a damp cloth or hot, soapy water.

Soap stains should be removed with water, and the glass should then thoroughly dried.

For encrusted dirt, it is recommended that you use a glass scraper, with a metal blade, which can easily be found on the market.

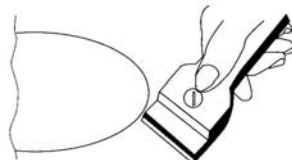

Only clean when the surfaces is cold.

BURNERS CLEANING (BFS60NX*; BFS60WX*)

The burners should be cleaned with soapy warm water and well rinsed and dried.

Ensure they are completely dry before using.

OVEN CLEANING

The oven should be washed with warm water and a nylon pad soaked in ordinary detergent.

REMOVING THE OVEN DOOR FOR CLEANING

For complete cleaning, we advise removing door working as follows:

- Set the door wide open
- Turn the brackets of the lower hinges upwards until hooking the upper hinges
- Set the door ajar, then lift lightly to remove the lower hinges from the slots
- Remove the door and the two upper hinges from their seats

Clean the door and reassemble reversing the above mentioned steps.

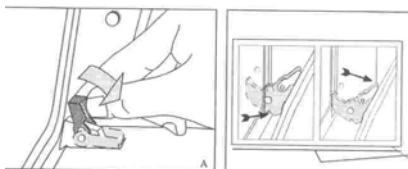

CLEANING OF THE FAN

Periodically the fan should be cleaned with warm water and suitable detergents:

Wait until the oven has cooled down.

Unscrew the four screws A

Unscrew the central nut C

Extract the fan D and clean it

Reassemble in the reverse order, paying attention that the central E seat coincides with the peg F placed on the motor shaft

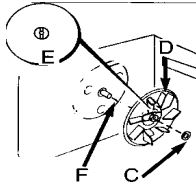
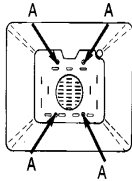

Protection Filter of the Oven Fan (Optional)

During the cooking, to minimise fat/debris going on to the fan, install the filter cover. When cooking is complete, remove the filter and wash it.

To install the filter, mount the filter leaning it against the rear wall at the same level of the fan, then push the "tang" downwards. Reverse this operation to remove the filter.

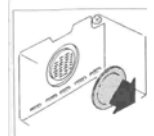

REPLACING THE OVEN BULB

Once the appliance has been electrically disconnected, unscrew the glass protection cap and the bulb, replacing it with another one suitable for high temperatures (300°C) having the following characteristics:

Voltage: 240 V

Power: 25 W

Socket: E14

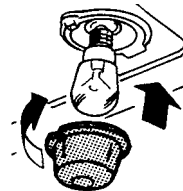

Reassemble the glass cup and reconnect the appliance.

Abnormal Operation

Any of the following are considered to be abnormal operation and may require servicing :

- . Yellow tipping of the hob burner flame.
- . Sooting up of cooking utensils.
- . Burners not igniting properly.
- . Burners failing to remain alight.
- . Burners extinguished by oven door.
- . Gas valves, which are difficult to turn.



In case the appliance fails to operate correctly, please call a TECHNICAL SERVICE CENTRE.



TABLES

Overall Dimensions (mm) 600W x 600D x 850/900H

TABLE 1 – GAS BURNERS					
	PROPANE GAS			NATURAL GAS	
Supply pressure	2.75kPa			1.13kPa	
Test Point Pressure	2.75kPa			1.00kPa	
SABAF II	Main Injector	By Pass Screw	Nominal Gas Consumption	Main Injector	Nominal Gas Consumption
Burners	mm	mm	MJ/h	mm	MJ/h
Auxiliary	0.53	0.29	3.8	0.90	4.0
Semi Rapid	0.68	0.34	6.3	1.20	7.2
Rapid	0.89	0.44	10.8	1.55	12.0
Wok	1.00	0.65	12.6	1.65	13.5

TABLE 2 – Recommended Pot Sizes		
	Recommended diameters, cm	
Burners	minimum	maximum
Auxiliary Ø 42	10	16
Semi-rapid Ø 62	15	22
Rapid Ø 92	20	26
Triple Ø 130	22	28

TABLE 3 – POWER, W		
	OVEN – STATIC	
	2 600 W	2 625 W

GRILL - STATIC 	GRILL - VENTILATED 
1 500 W	1 525 W







CIRCULAR RESISTANCE 	OVEN BULB 	VENTILATOR 
2300 W	25 W	25 W

PLATE HI-LIGHT Ø 145 mm  1200 W	PLATE HI-LIGHT Ø 180 mm  1800W	DOUBLE PLATE HI-LIGHT Ø 120/210 mm  700/2100W
		18

