

# Zip Domestic Chill Tap<sup>®</sup>

Undersink filtered / unfiltered domestic chilled drinking water



76121 - 60 Glass/Hr Filtered UCCT12FXV





## Read These Warnings First



Please read all installation requirements, installation procedures and precautions before installing any Zip Chill Tap.

Never attempt to install any Zip Chill Tap without reading all of the applicable instructions.

All electrical connections must comply with current wiring rules.

This appliance is not designed for use by young children or infirm people without supervision.

Young children should be prevented from having access to ensure they are not able to use or play with the chiller.

This appliance must be earthed.

If the power supply cord is damaged it must be replaced by a Zip Service Provider or a qualified electrician.

Do not remove the cover of the appliance under any circumstances without first isolating the appliance from the power supply.

## Domestic Installation Instructions

### Installing the Chiller

Sit the chiller unit into the cupboard as close to the proposed outlet tap position as is possible, to minimise the length of tubing exposed between the chiller unit and the outlet tap.

Allow at least 50 mm around the chiller unit to permit free airflow. Both the top and the front of the chiller must remain accessible for servicing purposes.

### Installing the Tap

If this model comes with a carafe filler, position and install the carafe filler at the back of the sink where there is a 45 mm wide flat area within the draining area of the sink.

Make sure the selected position allows the carafe filler spout to overhang the sink bowl.

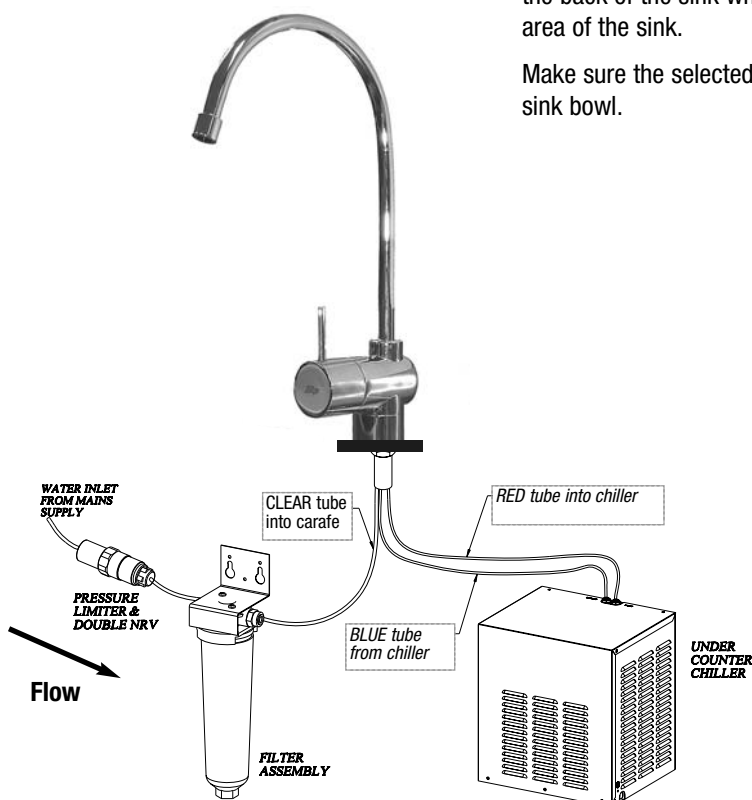

## Domestic Installation Instructions continued

Use a 25 mm sheet metal punch to create a neat hole without burrs.

Remove the nut and washer from the base of the carafe filler, leaving the rubber-sealing ring in place.

Fit the carafe filler and seal to the sink, oriented so that the operating lever is away from the sink bowl.

Slide the washer and nut over the tubes from under the sink, and tighten the nut to secure the carafe filler firmly into place.

### Connecting

If this model comes with a filtration kit, follow the separate filter kit installation instructions.

If this is an unfiltered model, only a 1/2" BSP to 1/4" tube adaptor is supplied.

You must separately supply and install an isolating valve in the supply line before the connection to the product.

If the pressure exceeds 700kPa, you must also supply and install a 350kPa pressure-limiting valve.

From the outlet of the pressure limiting valve or the outlet of the filter housing (if supplied) connect the CLEAR tubing from the vented carafe filler, cut excess off to ensure a neat job. Make sure all connections to John Guest fittings are pushed in past the "O"ring to full depth, at least 15-16mm.

Now measure and cut the RED tube to connect directly to the JG fitting marked INLET on the top right rear of the chiller unit. Insulate the BLUE tube with the loose length of the pipe insulation, cut both pieces to correct length. Now connect the BLUE tube to the JG fitting marked OUTLET on the top left rear of the chiller. Tap connection is now complete.

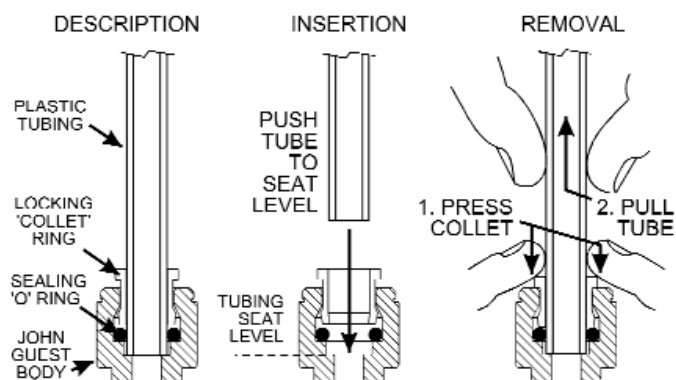

### Precautions

The plumbing installation must be done in accordance with local Water Authority regulations and these Installation Instructions.

As the installer, it is your responsibility to supply (if necessary) and install all valves as required by local regulations and relevant standards.

The chiller and filtration systems are indoor units and must not be exposed to the elements of nature.

## Domestic Installation Instructions continued

Take care, when bending rigid plastic tubing, to prevent it from kinking or crushing around a bend. As it is plastic tubing containing water under mains pressure, be careful not to nick, scratch or damage it during installation.

Cut the tube squarely with a sharp knife or tube cutter. Shake out and remove any swarf and debris.

Ensure there is adequate ventilation available through the cupboard. If there is inadequate ventilation, and the cupboard temperature rises to above 40°C, the chiller may become damaged and malfunction which will void the product warranty.

There must be a minimum 168cm<sup>2</sup> of cupboard cross-flow ventilation. Suitable holes or vents will need to be cut into the cupboard and door.

For safe operation, thoroughly flush the water through after non-use periods longer than 12 hours.

Filter cartridges (if fitted) should be replaced at least every 6-12 months, or sooner if you notice:

- A. a persistent reduction in water pressure from the product, or;
- B. an unpleasant taste or odour in the water.

Not changing the cartridges when required may cause the water to become biologically unsafe.

### Commissioning

Clip the tubing in the cupboard. After the appliance is installed and connected, turn "ON" the water supply. Check all connections for leaks. Repair any found.

The filters (if fitted), chiller and tubing are full of air until purged. Press the operating lever on the appliance outlet tap for a minimum of five minutes until all of the air has been purged from the system.

Plug the 3-pin power cord into a standard power point. Do NOT turn "ON" until after the unit is purged.

Wipe clean and dry the area.

Dispose of packaging wisely.



The use of this crossed out wheeled bin logo indicates that this product needs to be disposed of separately to any other household waste.

Within each of the European Union member countries, provisions have been made for the collection and recycling of unwanted electrical and electronic equipment. Outside of the EU it will be necessary to dispose of this product at your local community waste collection or recycling centre.

In order to help preserve our environment we ask that you dispose of this product correctly. Please contact your local city council for collection centre details

## Domestic Operating Procedures

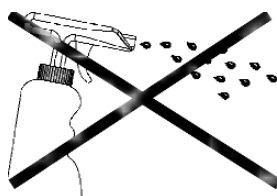
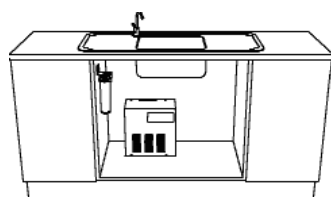

### Operation

Chilled water is obtained by rotating the lever on the carafe filler. The water is chilled by a refrigeration unit fitted within the cabinet stand, under the basin.

With the carafe filler, you can obtain chilled water within the rated capacity, for as long as you leave the lever in the open (vertical) position. When finished, return the lever to the OFF (upright) position.

### Cleaning

Never use strong, corrosive or abrasive cleaning materials on the Zip Chill Tap. Wipe clean the outer surfaces with a sponge or a soft cloth using a mild soap and water.

The louvres on the sides of the chiller unit need to be kept free of dust and lint to permit free flow of air through the vents. They should be checked regularly, at least monthly, and dusted or vacuumed.

### Filter Replacement

The Zip Chill Tap Under Counter Chiller may have a separate filtration system connected to the incoming water supply line, and which may be located within the same cupboard as the chiller unit.

For safe operation, the filter cartridge should be replaced every 6-12 months, or earlier if you notice a persistent reduction in water pressure from the appliance or an unpleasant taste or odour in the water.

### WARNING

**Not changing filtration cartridges when required, may cause the water to become biologically unsafe. Make an entry in your diary to check the water quality of the Chill Tap at least six months after installation and after every subsequent filter change.**

**Use only a Zip Filter to match that used with this Chill Tap (if fitted). Replacement filter cartridges can be obtained through plumbing suppliers or directly from Zip.**

**Replacement instructions come with the filter cartridges.**

**Before attempting to disconnect or remove the filter cartridge from the housing, isolate (turn off) the water supply prior to the filter system, and then relieve the system pressure by operating the chilled water outlet tap until the water ceases to flow.**

### Service

There are no user serviceable parts but there are dangerous voltages present within the unit. All service work must only be carried out by a suitably qualified and experienced service person.

Before calling for service, check that both the water and electricity supplies are turned 'ON' and OK.

Call an electrician, a plumber, or Zip for a free call in Australia on 1800-638-633, for assistance, service, spare parts, or enquiries.

## Domestic Warranty Information

Certain warranties may be implied by law into your contract with Zip. The warranty provided below is additional to these implied warranties and nothing set out below shall limit your statutory rights or rights at law.

Zip Heaters (Aust) Pty Ltd warrants that, should any part fail within 12 calendar months of installation, that part will be repaired or replaced free of charge by Zip or its Distributor or Service Provider, except as set out below, provided the appliance is installed and used strictly in accordance with the instructions supplied, and that failure is not due to accident, misuse, abuse, unsuitable water conditions, or to any alteration, modification or repair by any party not expressly nominated by Zip.

No costs are payable by the customer other than any mileage or travelling-time charges incurred by a Zip Service Provider or the cost of removal, cartage and re-installation of any component of the appliance if it needs to be returned for repair to Zip or its Distributor.

This warranty does not cover damage resulting from non-operation of the appliance, the use of non authorised parts or consequential damage to any other goods, furnishings or property.

No warranty applies to the life of any filtration cartridge installed with the appliance as cartridge life may vary according to water quality and the rate of water consumption.

Zip does not exclude, restrict or modify any liability that cannot be excluded, restricted or modified or which cannot, except to a limited extent, be excluded, restricted or modified as between the owner or user and Zip under the laws applicable.

Furthermore, this warranty does not displace any statutory warranty, but, to the extent to which Zip is entitled to do so, the liability of Zip under any statutory warranty will be limited at Zip's option to the replacement of the appliance or supply of equivalent appliance, the payment of the cost of replacing the appliance or acquiring an equivalent appliance, or the payment of the cost of having the appliance repaired or the repair of the appliance.

### **Registering Your Purchase**

Registering your Zip installation on the Zip website may help to establish date of installation should it become necessary to service the appliance under terms of the Zip warranty. To register your installation go to [www.zipheaters.com](http://www.zipheaters.com) and look under the heading "Warranty".

As Zip policy is one of continuous product improvement, changes to specifications may be made without prior notice. Images in this booklet have been modified and may not be true representations of the finished goods.

## Contact Details

### Head Office

Zip Heaters (Aust) Pty. Ltd.  
ABN 46 000 578 727  
67 Allingham Street  
Condell Park NSW 2200  
Postal: Locked Bag 80  
Bankstown 1885 Australia

Website: [www.zipheaters.com](http://www.zipheaters.com)  
Facsimile (02) 9796 3858  
Telephone (02) 9796 3100  
Free Call 1 800 638 633

