



INSTALLATION and SERVICE INSTRUCTIONS
USE and CARE INSTRUCTIONS

PYROLYTIC OVENS



distributed by
DèLonghi
Pty Ltd

Dear Customer,

Thank you for having purchased and given your preference to our product.

The safety precautions and recommendations reported below are for your own safety and that of others. They will also provide a means by which to make full use of the features offered by your appliance.

Please keep this booklet in a safe place. It may be useful in future, either to yourself or to others in the event that doubts should arise relating to its operation.

This appliance must be used only for the task it has explicitly been designed for, that is for cooking foodstuffs. Any other form of usage is to be considered as inappropriate and therefore dangerous.

The manufacturer declines all responsibility in the event of damage caused by improper, incorrect or illogical use of the appliance or be faulty installation.

PRODUCT LABEL



IMPORTANT PRECAUTIONS AND RECOMMENDATIONS FOR USE OF ELECTRICAL APPLIANCES

Use of any electrical appliance implies the necessity to follow a series of fundamental rules. In particular:

- Never touch the appliance with wet hands or feet;
- Do not operate the appliance barefooted;
- The appliance is not intended for use by young children or infirm persons without supervision
- Young children should be supervised to ensure they do not play with the appliance

The manufacturer cannot be held responsible for any damages caused by improper, incorrect or illogical use of the appliance.

This oven has been designed and constructed in accordance with the following codes and specifications:

- AS/NZS 60335-1 General Requirements for Domestic electrical appliances
 - AS/NZS 60335-2-6 Particular Requirements for Domestic electrical cooking appliances
 - AS/NSZ 1044 Electromagnetic Compatibility Requirements.
-

IMPORTANT PRECAUTIONS AND RECOMMENDATIONS

After having unpacked the appliance, check to ensure that it is not damaged. In case of doubt, do not use it and consult your supplier or a professionally qualified technician. Packing elements (i.e. plastic bags, polystyrene foam, nails, packing straps, etc.) should not be left around within easy reach of children, as these may cause serious injuries.

- Do not attempt to modify the technical characteristics of the appliance as this may become dangerous to use.
- Do not carry out cleaning or maintenance operations on the appliance without having previously disconnected it from the electric power supply.
- After use, ensure that the knobs are in the off position.
- The appliance is not intended for use by young children or infirm persons unless they have been adequately supervised by a responsible person to ensure that they can use the appliance safely.
- During and after use of the appliance, certain parts will become very hot. Do not touch hot parts. Care should be taken to avoid touching heating elements inside the oven.
- Keep children away from the appliance when it is in use.
- Young children should be supervised to ensure that they do not play with the appliance.
- Some appliances are supplied with a protective film on steel and aluminium parts. This film must be removed before using the appliance.
- Make sure that electrical cables connecting other appliances in the proximity of the oven are not entrapped in the oven door.
- Do not line the oven walls with aluminium foil. Do not place baking trays or the drip tray on the base of the oven chamber.
- **WARNING** When correctly installed, your product meets all safety requirements laid down for this type of product category. However special care should be taken around the rear or the underneath of the appliance as these areas are not designed or intended to be touched and may contain sharp or rough edges, that may cause injury.
- **Fire risk!** Do not store flammable material in the oven.
- Always use oven gloves when removing the shelves and food trays from the oven whilst hot.
- Do not hang towels, dishcloths or other items on the appliance or its handle – as this could be a fire hazard.
- Clean the oven regularly and do not allow fat or oils to build up in the oven base or tray. Remove spillages as soon as they occur.
- Do not stand on the open oven door.
- Always stand back from the appliance when opening the oven door to allow steam and hot air to escape before removing the food.
- This appliance is for domestic use only.
- Safe food handling: leave food in the oven for as short a time as possible before and after cooking. This is to avoid contamination by organisms which may cause food poisoning. Take particular care during warmer weather.
- The manufacturer declines all liability for injury to persons or damage to property caused by incorrect or improper use of the appliance.
- **WARNING: Taking care NOT to lift the oven by the door handle.**
- **IMPORTANT NOTE: This appliance shall not be used as a space heater, especially if installed in marine craft or caravans.**

CAUTION:

- This appliance must be installed in accordance with these installation instructions.
- This appliance shall only be serviced by authorized personnel.
- This appliance is to be installed only by an authorised person.
- Incorrect installation, for which the manufacturer accepts no responsibility, may cause personal injury or damage.
- Always disconnect the oven from mains power supply before carrying out any maintenance operations or repairs.

ELECTRICAL REQUIREMENTS

- The oven is supplied without a power supply plug and therefore if you are not connecting directly to the mains, a standardized plug suitable for the load must be fitted.
- Connection to the mains must be carried out by qualified personnel in accordance with current regulations.
- The appliance must be connected to the mains checking that the voltage corresponds to the value given in the rating plate and that the electrical cable sections can withstand the load specified on the plate.
- The plug must be connected to an earthed socket in compliance with safety standards.
- The appliance must be connected directly to the mains placing a two pole switch with minimum opening between the contacts of 3 mm between the appliance and the mains.
- The power supply cable must not touch the hot parts and must be positioned so that it does not exceed 75°C at any point.
- Once the appliance has been installed, the switch or socket must always be accessible.
- If the supply cord is damaged it must be replaced by the manufacturer or its Service Agent or a similarly qualified person in order to avoid a hazard.

- N.B.**
- The connection of the appliance to earth is mandatory.
 - For connection to the mains, do not use adapters, reducers or branching devices as they can cause overheating and burning.

If the installation requires alterations to the domestic electrical system call a qualified electrician. He should also check that the socket cable section is suitable for the power drawn by the appliance.

REPAIRS

REPLACING THE POWER SUPPLY CABLE

- Unhook the terminal board cover by inserting a screwdriver into the two hooks "A" (fig. 1.2).
- Open the cable gland by unscrewing screw "F" (fig. 1.3), unscrew the terminal screws and remove the cable.
- The new supply cable, of suitable type and section, is connected to the terminal board following the diagram fig. 1.1.

FEEDER CABLE SECTION TYPE HO5RR-F

Appliance power rating:	230 V~	3095 W (13.4 A)	3 x 1.5 mm ²
	240 V~	3370 W (14.0 A)	3 x 1.5 mm ²

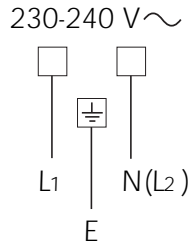
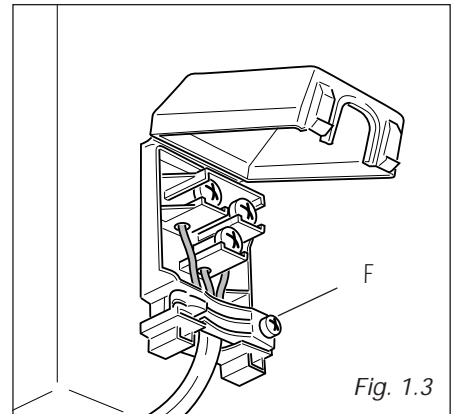
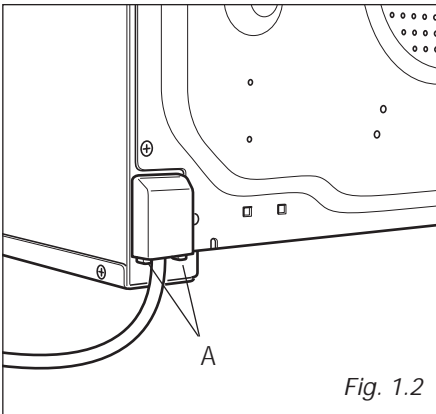

Fig. 1.1



ELECTRIC DIAGRAM - multifunction OVENS

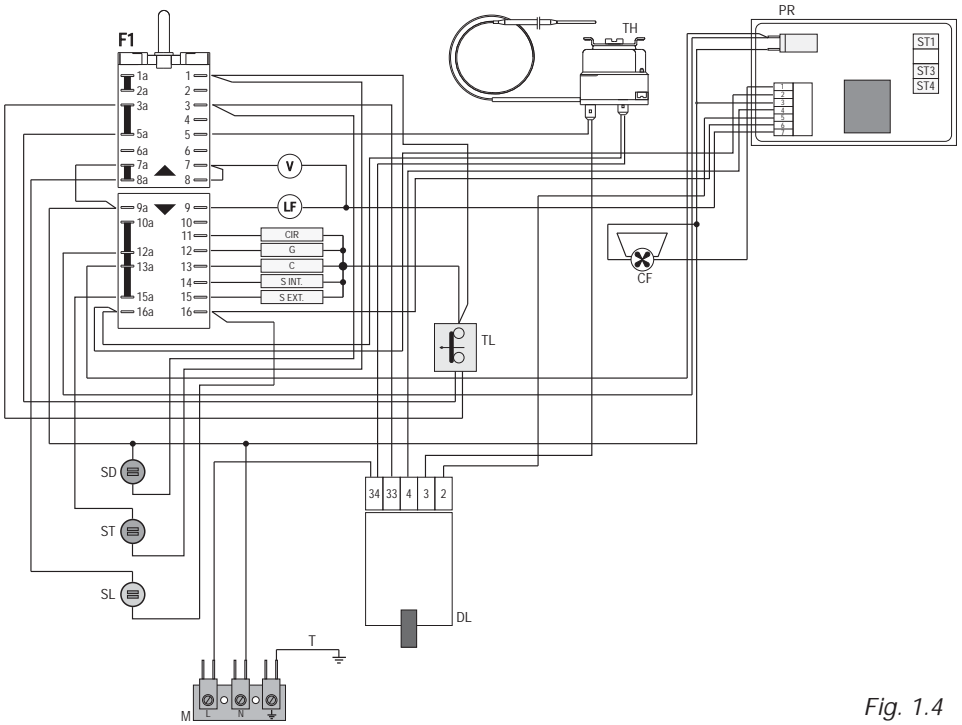

Fig. 1.4

F1	Oven switch	CIR	Circular element
TH	Safety thermostat	G	Grill element
ST1	Oven sensor switch	C	Top element
ST3	Oven door switch	S INT.	Bottom element 1
ST4	Encoder switch	S EXT.	Bottom element 2
PR	Programmer	M	Terminal block
TL	Thermal overload	T	Earth connection
DL	Door locking safety device		
CF	Cooling fan		
LF	Oven lamp		
V	Fan		
ST	Thermostat pilot lamp		
SL	Line pilot lamp		
SD	Door locking pilot lamp		

FITTING REQUIREMENTS

WARNING: Taking care NOT to lift the oven by the door handle.

The oven must be built-in in a standard module of furniture of 60 cm width and depth. It is to be fit up in a module having the clearance as shown in the pictures. On the lower side, the oven must lay on supports standing the oven weight. The ovens are secured by four screws that pass through the surround. They must locate firmly and squarely in the edges of the cabinet or add panels to achieve a secure location.

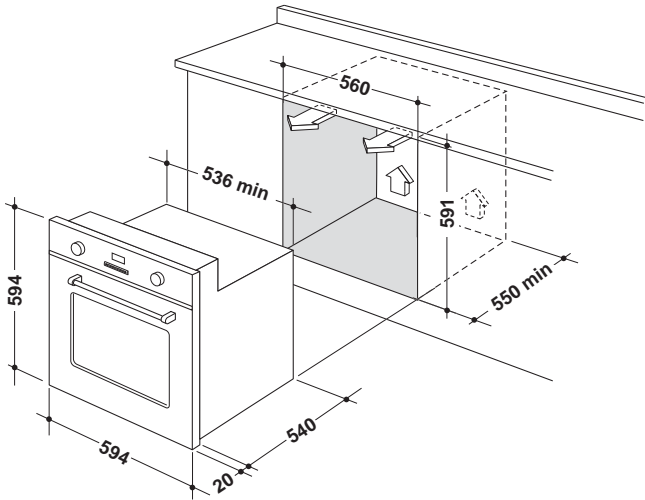

Fig. 1.5

FITTING THE OVEN INTO A BASE

The space available should be of the dimensions shown in the figure 1.5. Arrangements should be made for an adequate supply of the air to the oven to avoid overheating (fig. 1.6).

The walls surrounding the oven must be made of heat-resistant material. Both the veneered plastic and the adhesive used must be resistant to temperatures of 120°C in order to prevent unsticking and deformation.

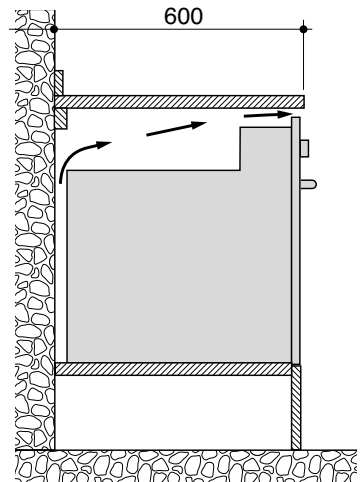

Fig. 1.6

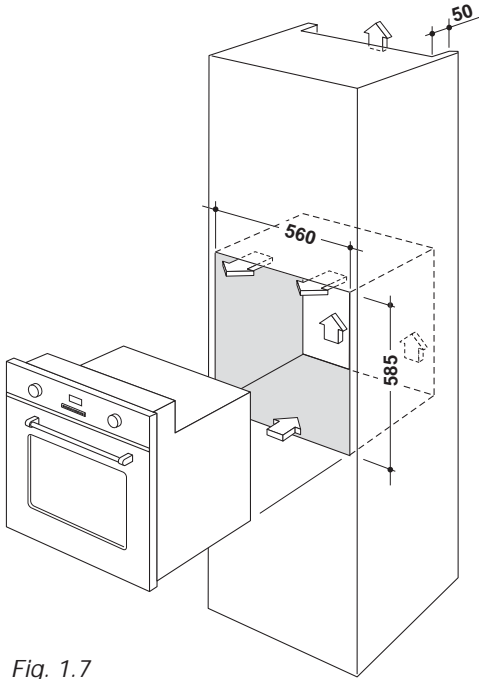

Fig. 1.7

FITTING THE OVEN INTO A COLUMN

The cabinet should have the dimensions as per fig. 1.7.

Furthermore it is necessary that the oven is provided with a chimney as per fig. 1.8.

If the column unit reaches the ceiling an outlet must be provided through which air can flow to the outside

WARNING

When correctly installed, your product meets all safety requirements laid down for this type of product category. However special care should be taken around the rear or the underneath of the appliance as these areas are not designed or intended to be touched and may contain sharp or rough edges, that may cause injury.

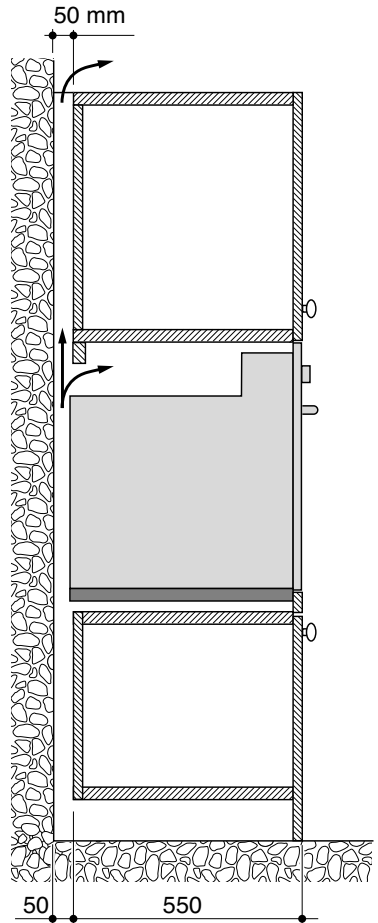

Fig. 1.8 9

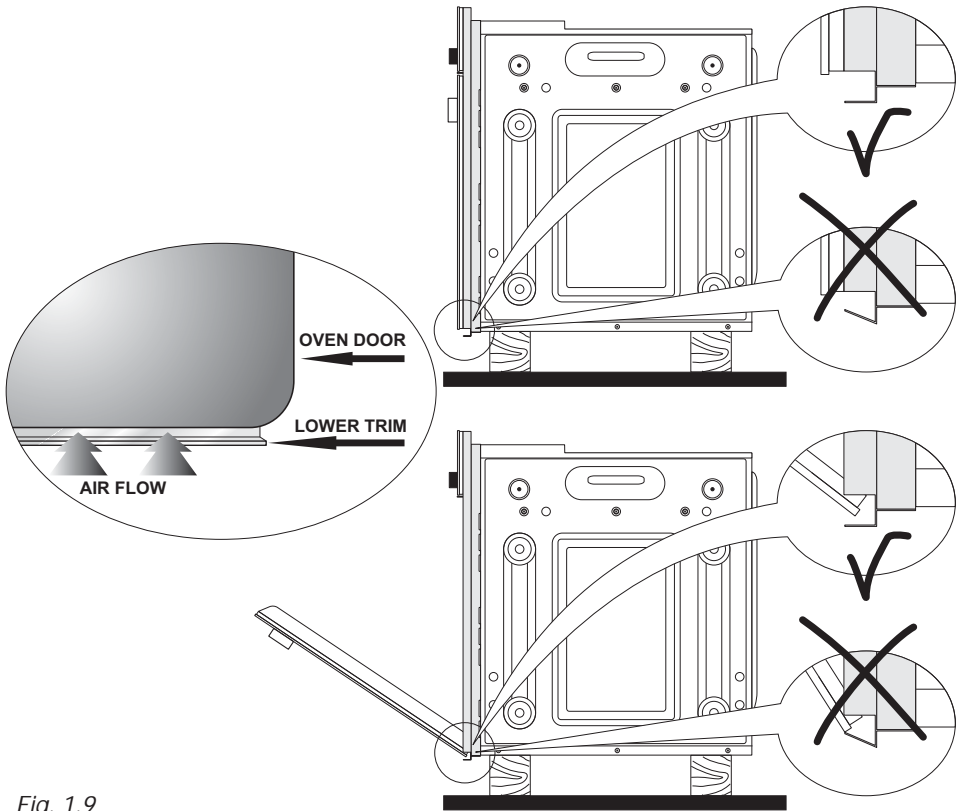

Fig. 1.9

IMPORTANT:

Please take extra care not to damage the lower trim of the oven.

Ensure the oven sits on wooden blocks or similar supports when it is removed from the carton as shown in above diagram. This will prevent any damage to the lower trim.

Should the lower trim become damaged, straighten the trim and ensure the oven door opens fully without obstruction from the lower trim.

After installation check the lower trim is still undamaged.

The space between the bottom of the door & the lower trim is important to allow proper air circulation into the oven.

The oven door should be opened slowly to it's fully open position ensuring there is adequate clearance between the bottom of the door and the lower trim.

The manufacturer does not accept responsibility for any damage to the oven resulting from incorrect installation.

CAUTION:

- This appliance must be used only for the task it has explicitly been designed for, that is for domestic cooking of foodstuffs. Any other form of usage is to be considered as inappropriate and therefore dangerous.
- Do NOT place combustible materials or products on this appliance at any time.

OVEN SHELVES

- The oven shelves are provided with a security block to prevent accidental extraction.
- They must be inserted operating as per figure 2.1.
- To pull them out operate in the inverse order.

GREASE FILTER

- Slide in the grease filter on the back of the oven as in fig. 2.2.
- Clean the filter after any cooking!

The grease filter can be removed for cleaning and should be washed regularly in hot soapy water (fig. 2.2).

- Always dry the filter properly before fitting it back into the oven.

CAUTION: The filter must be taken out of the oven before starting the pyrolysis cycle.

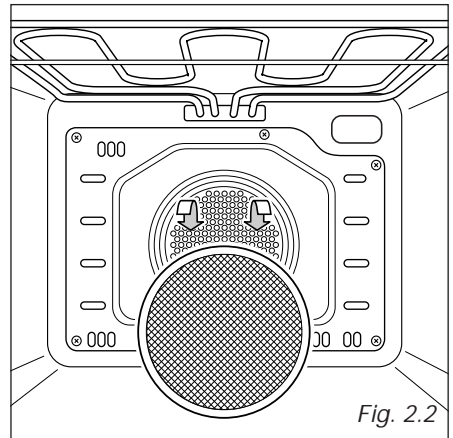
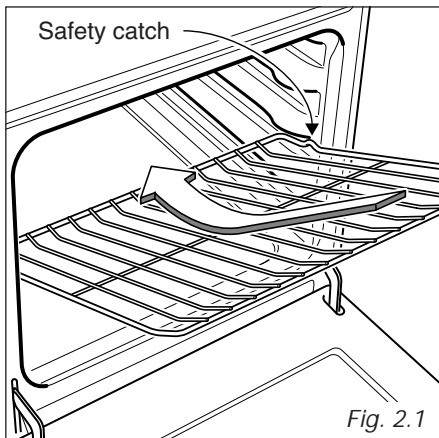

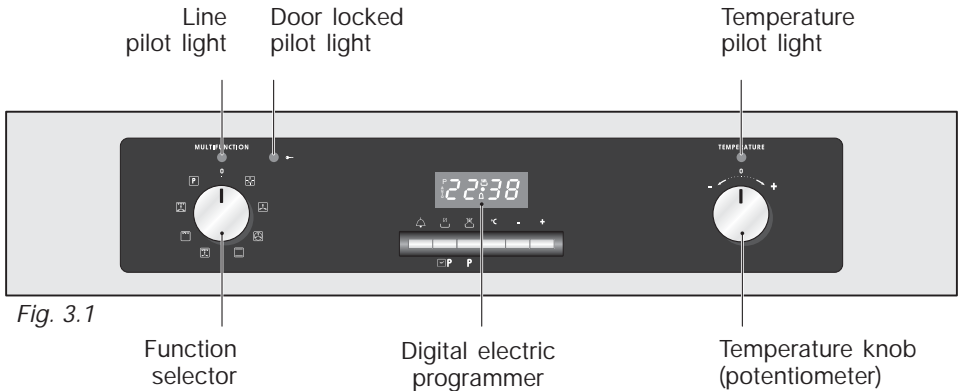

Fig. 3.1

GENERAL FEATURES

This oven has special operating features.

5 different functions can be used to satisfy all cooking needs; it also has a pyrolytic function which can clean the oven cavity at high temperature, a defrost function and an oven light function.

The functions are managed by an electronic programmer which keeps the temperature set constant by means of a probe inside the oven cavity.

The oven has the following heating elements:

- Lower heating element (double) 500 + 1300 W
- Upper heating element 1000 W
- Grill heating element 2000 W
- Circular heating element 2200 W

WARNING:

The door is hot, use the handle.

During use the appliance becomes hot. Care should be taken to avoid touching heating elements inside the oven.

OPERATING PRINCIPLES

Heating and cooking in the multifunction pyrolytic oven takes place as follows:

■ **by normal convection**

The heat is produced by the upper and lower heating elements.

■ **by forced convection**

A fan sucks in the air contained in the oven, which circulates it through the circular heating element and then forced back into the oven by the fan. Before the hot air is sucked back again by the fan to repeat the described cycle, it envelops the food in the oven, provoking a complete and rapid cooking. It is possible to cook several dishes simultaneously.

■ **by radiation**

The heat is radiated by the radiant grill element.

■ **by radiation and fan**

The radiated heat from the radiant grill element is distributed throughout the oven by the fan.

■ **by double radiation and fan**

The fan distributes the heat radiated by the grill heating element and the upper heating element in the oven.

■ **by ventilation**

The food is defrosted by using the fan only function without heat.

■ **by pyrolysis**

The heat produced by the heating elements cleans the internal oven cavity removing all residue of grease. **THIS IS NOT A COOKING FUNCTION**

USING THE OVEN FOR THE FIRST TIME

- Put in the shelves and trays.
- Switch the oven on empty (on a cooking function – **NOT PYROLYSIS**) at maximum power for about 2 hours to remove traces of grease and smells from the components.
- When the oven has cooled down and unplugging it, clean the inside of the oven with a cloth soaked in water and neutral detergent and dry it perfectly.

NOTES ON OVEN WORKING

A cooling fan starts automatically when the temperature inside the oven cavity is higher than 100°C and stops when the temperature drops below 100 °C.

For the pyrolytic function only, it starts immediately the pyrolytic cycle starts. The purpose of this fan is to reduce the temperature inside/outside the appliance.

Attention: the oven door becomes very hot during operation. Keep children away.

Note: The first time the oven is used or after a black-out the programmer must be started by pressing keys 2 and 3 simultaneously. See the chapter on the use of the electronic programmer.



SELECTING THE FUNCTIONS (fig. 3.2)

The cooking function is selected by turning the function selector knob and matching the mark with the symbol printed on the print.

Important: In all cooking functions the oven must always be used with the DOOR CLOSED.

If the door stays open "door" appears on the programmer display and after five minutes an audible warning sounds for 30 seconds and "door" flashes.



To silence the audible warning press any programmer pushbutton.

NOTE: The heating elements work even with the door open and this signal just indicates that energy is being wasted.

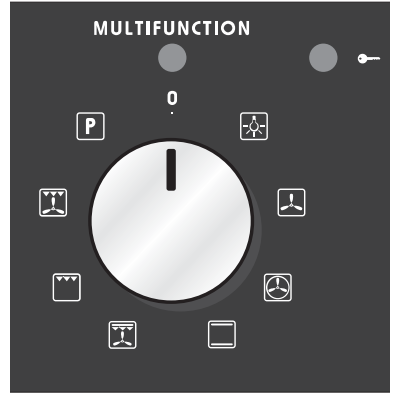

Fig. 3.2



OVEN LIGHT

On turning the knob to this position only the oven lamp lights up. The lamp is always on in all the cooking functions (not for the pyrolysis).



DEFROSTING FROZEN FOODS (this is not a cooking function)

Only the fan and the oven lamp switch on. Defrosting takes place by fan, without heating. The electronic programmer shows **dEF**.



Recommended for:

To rapidly defrost frozen foods; 1 kilogram requires about one hour. The defrosting times vary according to the quantity and type of foods to be defrosted.



HOT AIR COOKING

The circular heating element and the fan switch on. The heat is diffused by forced convection and the temperature can be set between 50 and 250 °C.

On selecting this function the electronic programmer starts cooking with a pre-heating time set at 180 °C. To vary the temperature see the "Setting the cooking" chapter.

Recommended for:

For foods that must be well done on the outside and tender or rare on the inside, i. e. lasagna, lamb, roast beef, whole fish, etc.



TRADITIONAL CONVECTION COOKING

The upper and lower heating elements switch on.

The heat is diffused by natural convection and the temperature must be set between 50 and 250 °C.

On selecting this function the electronic programmer starts cooking with a pre-heating time set at 200 °C. To vary the temperature see the "Setting the cooking" chapter.

Recommended for:

For foods which require the same cooking temperature both internally and externally, i. e. roasts, spare ribs, meringue, etc.



FAN COOKING WITH DOUBLE GRILL

The radiant grill, the upper heating element and the fan switch on. The heat is mainly diffused by radiation and the fan distributes it in the whole oven. The temperature can be set between 50 and 250 °C.

On selecting this function the electronic programmer starts cooking with a pre-heating time set at 240 °C. To vary the temperature see the "Setting the cooking" chapter.

Recommended for:

Meats which are to be cooked at a high temperature but which must remain tender. Fish remains more tender; turn it once during cooking.



GRILLING

The radiant heating element switches on.

The heat is diffused by radiation. The temperature can be set between 50 and 250 °C.

On selecting this function the electronic programmer starts cooking with a pre-heating time set at 210 °C. To vary the temperature see the "Setting the cooking" chapter.

Recommended for:

Intense grilling action for cooking with the broiler; browning, crisping, "au gratin", toasting, etc. For correct use see the "Grilling" chapter.



FAN GRILLING

The radiant heating element and the fan switch on. The heat is mainly diffused by radiation and the fan distributes it in the whole oven.

The temperature can be set between 50 and 250 °C.

On selecting this function the electronic programmer starts cooking with a pre-heating time set at 220 °C. To vary the temperature see the "Setting the cooking" chapter.

Recommended for:

For grill cooking when a fast outside browning is necessary to keep the juices in, i. e. veal steak, steak, hamburger, etc.

For correct use see the "Fan grilling" chapter.



PYROLYSIS FUNCTION

IMPORTANT NOTES:

This is not a cooking function but is only used to clean the oven.

Before starting the pyrolytic cycle:

- Take all the accessories out of the oven (drip tray and shelves). If the oven has an anti-grease filter unhook and remove it, as described on page 11.
- Clean any traces of liquid which have overflowed.
- Close the oven door and make sure that it is closed properly.

If there are cracks or flaws on the oven door glass (inside/outside) or if the gaskets are ruined or worn or if the door does not close perfectly, unplug the appliance and contact the After-Sales Service Centre.

GENERAL INFORMATION

- In this function the residual cooking greases on the inside walls of the oven cavity are pulverised by the high temperature. The fumes produced during this process are filtered by a special catalyst in the upper part of the appliance.
- Smells and fumes produced during pyrolysis are not a cause of alarm. Adequate ventilation should however be provided in the room where the oven is installed, e.g. by opening a window.
- Do not wait for the oven to be very greasy before performing this cleaning. It should not be performed after every cooking, either, but only when the level of dirt justifies it (on average 1 – 2 times a month depending on oven use).
- For safety reasons (high temperature of the oven cavity), when the pyrolysis starts the oven is automatically locked by an electronic device (on the control panel the pilot light with key symbol lights up). The door can no longer be opened and is only unlocked at the end of the cleaning cycle or, stopping the cycle, when the oven cavity has cooled to a temperature lower than 300 °C.
- When the pyrolytic function starts an internal fan starts automatically to cool the oven walls. It only stops at the end of the cycle, when the oven cavity temperature has dropped below 100 °C.
- The procedures for starting, stopping and completing the pyrolysis cycle and dealing with any problems are described in the following chapters:
 - "How to start the pyrolysis cycle"
 - "Problems in starting and during the pyrolysis cycle"
 - "How to stop the pyrolysis cycle"
 - "What to do when the pyrolysis cycle has finished"
 - "Abnormal situations and/or operating problems"
- Caution: during the pyrolytic cycle the accessible parts may become hot. Keep children away.

SETTING THE COOKING (only for the cooking functions)

Way 1: SETTING THE COOKING TEMPERATURE WITH THE TEMPERATURE KNOB (POTENTIOMETER)



Fig. 3.3

NOTE: The temperature knob (potentiometer) turns to right and left only to symbols + and -. Forcing the turning could irreparably damage the temperature knob.

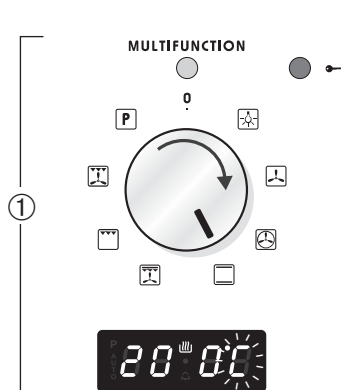

The temperature set is shown on the electronic programmer display and can be varied, with 5 °C intervals, by turning the potentiometer knob. During the cooking the oven temperature is measured by a sensor inside the cavity and is shown on the programmer display.

1. SELECTING THE COOKING FUNCTION Turn the selector knob to the cooking function required

The pre-set temperature appears on the programmer display. °C flashes on the display for 3 seconds. The heating elements start cooking immediately.

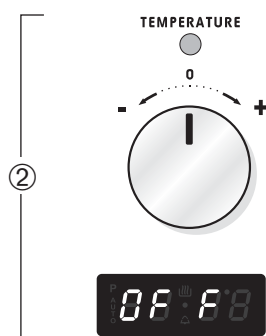

2. SETTING THE COOKING TEMPERATURE Turn the potentiometer knob clockwise to increase the temperature or anticlockwise to reduce it.

The maximum temperature which can be set is 250°C while the minimum temperature is 50 °C.

Note: When °C becomes steady the value shown on the display indicates the oven cavity temperature.

Caution: If a temperature below the minimum value (50 °C) is set the system switches off automatically and **OFF** appears.

In this case repeat the procedure from point 2.



3. SWITCHING OFF Turn the selector knob to position 0 (oven OFF). The programmer display shows the time.

SETTING THE COOKING (only for the cooking functions)

Way 2: SETTING THE COOKING TEMPERATURE WITH THE PROGRAMMER

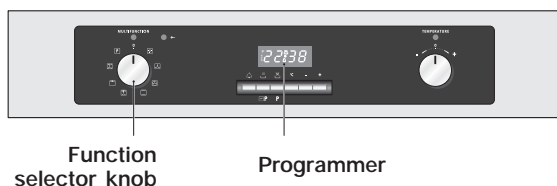
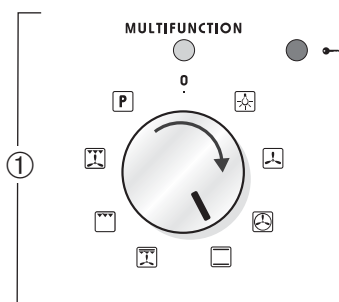

Fig. 3.4



The temperature set is shown on the electronic programmer display and can be varied, with 5 °C intervals, by turning the potentiometer knob. During the cooking the oven temperature is measured by a sensor inside the cavity and is shown on the programmer display.

1. SELECTING THE COOKING FUNCTION

Turn the selector knob to the cooking function required

The pre-set temperature appears on the programmer display. °C flashes on the display for 3 seconds. The heating elements start cooking immediately.

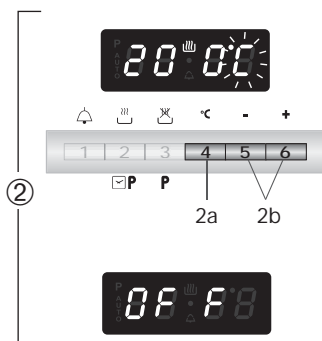

2. SETTING THE COOKING TEMPERATURE

The temperature can be changed when °C is flashing on the display

2a. If °C is not flashing press key 4 of the programmer.

2b. Press key 6 to increase the temperature or key 5 to reduce it.

The maximum temperature which can be set is 250 °C while the minimum temperature is 50 °C.

Note: When °C becomes steady the value shown on the display indicates the oven cavity temperature.

Caution: If a temperature below the minimum value (50 °C) is set the system switches off automatically and **OFF** appears.

In this case repeat the procedure from point 2.



3. SWITCHING OFF

Turn the selector knob to position **0** (oven OFF). The programmer display shows the time.

HOW TO START THE PYROLYSIS CYCLE

Important: the pyrolysis cycle must only be performed with the oven empty; so, before starting the cycle take all the accessories (shelves, drip tray, baking tray and anti-grease filter) out of the oven cavity and dry any traces of overflowed liquid.

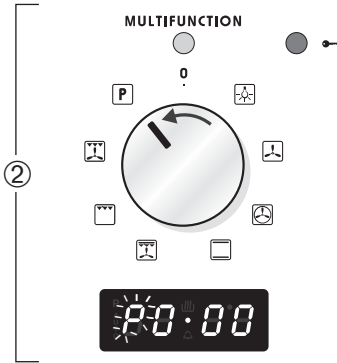

Do not use any degreasing products (e.g. degreasing sprays, detergents, etc.).

1. Close the oven door (if it is open or not closed properly the pyrolysis cycle will not start).

2. Turn the oven selector knob to the pyrolysis position (P); **P0•00** appears on the electronic programmer display with the letter **P** flashing.

3. Press pushbutton 3 on the programmer to start the cycle.

This combined confirmation operation offers greater safety when there are children; in fact turning the knob to the pyrolysis function has no effect if key 3 of the programmer is not then pressed.

- **P1•30** (pyrolysis time, 1 hour and 30 minutes) appears and the door is locked;

- On the control panel the pilot light with the key lights up to indicate that the door is locked.

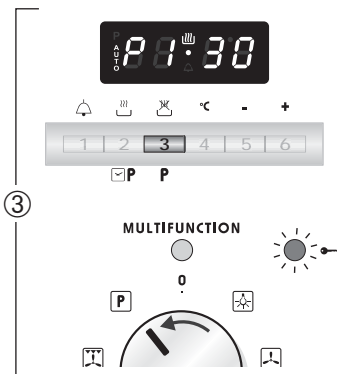

4. To increase the pyrolysis cycle time (max 3 hours) press key 2 of the programmer then key 6. To go backwards to the minimum of 1 hour and 30 minutes press key 2 then key 5.

- During the setting **AUTO** flashes and **P** disappears.

5. The pyrolysis cycle starts immediately and is completed in the programmed time.

- Throughout the pyrolysis cycle the programmer displays the time (hours and minutes) remaining until the cycle is finished.



VERY IMPORTANT:

The pyrolysis only starts with the oven door closed. If the door is open or not closed properly the oven CANNOT perform the pyrolysis; electronic safety devices prevent the pyrolysis from starting.

PROBLEMS ON STARTING AND DURING THE PYROLYSIS CYCLE



1. Steady door

The function selector has been turned to the pyrolysis position with the oven door open or not perfectly closed. Or the door has been opened before the cycle has been started with confirmation from key 3

What to do:

Close the door and repeat the operations to start the cycle.

- If after 5 minutes the door has not been closed **door flashes and an audible signal sounds for 30"**.

What to do:

Close the door, press any programmer key to silence the audible signal and repeat the operations to start the cycle.



2. door with AUTO flashing

The oven door has been opened after the pyrolysis cycle has started. The pyrolysis cycle is zeroed.

What to do:

1. Close the door. **P0•00** appears on the electronic programmer display with the letter **P** and **AUTO** flashing.
2. Turn the function selector to **0** and repeat the operations to start the cycle.

- If after 5 minutes the door has not been closed **door flashes and an audible signal sounds for 30"**.

What to do:

Close the door, press any programmer key to silence the audible signal and repeat the operations to start the cycle..



3. F0.00 with AUTO flashing

The pyrolysis cycle has been stopped and then started again when it was quite a way through. The message is displayed after about 10 minutes and the pyrolysis cycle is zeroed.

What to do:

1. Put the switch to **0**.
2. Wait for at least 15 minutes.
3. Repeat the operations to start the Pyrolysis cycle.
4. If after several attempts the message continues contact the After-Sales Service Centre.

Caution: It is advisable not to stop the pyrolysis cycle and then start it again when it is quite a way through.







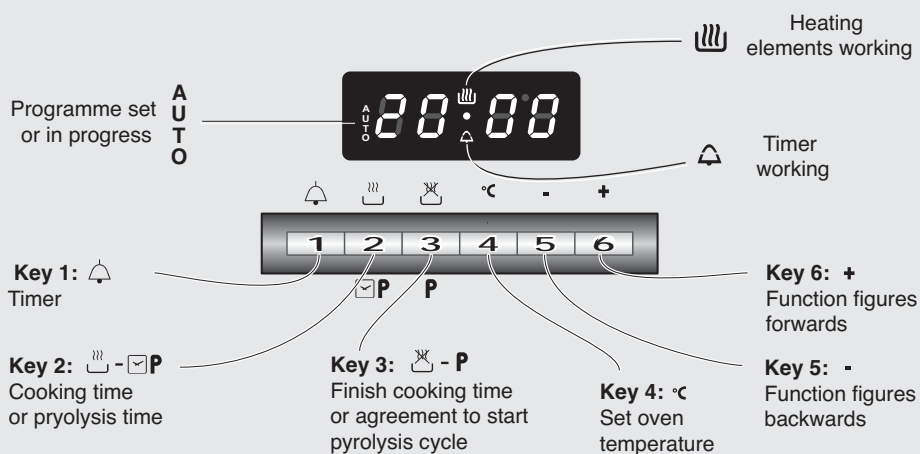











PYROLYTIC OVEN - QUICK GUIDE

Quick guide to be removed and used as a reminder after reading the instruction booklet carefully.



PROGRAMMER MESSAGE	MESSAGE MEANING	WHAT TO DO
	There has been a power cut or it is the first time the oven has been switched on	Set the time by pressing first keys 2 and 3 together, then keys 5 or 6.
 variable	Time	To set the time press keys 2 and 3 together, then keys 5 or 6.
 variable	Time with bell symbol ON. Timer counting backwards.	To display the timer count press pushbutton 1. To cancel the timer press pushbutton 1 then the key - until 00.00 appears.
 variable	Time with AUTO ON. Cooking programme set. The cooking has not yet started; the oven is OFF.	To display the end of cooking time press key 3; to display the cooking time press key 2. To cancel the programme turn the function selector knob to 0 .
 variable	Time with AUTO and cooking symbol ON. Cooking programme in progress. The oven is ON.	To display the end of cooking time press key 3; to display the cooking time press key 2. To cancel the programme turn the function selector knob to 0 .

PROGRAMMER MESSAGE		MESSAGE MEANING	WHAT TO DO
 variable		Cooking time set or oven temperature measured by the internal sensor.	To change the cooking temperature press key 4 of the programmer, then keys 5 or 6.
		A temperature below 50°C has been set. The oven has switched off.	Press key 4 of the programmer, then keys 5 or 6.
		dEF = defrost The “defrosting frozen food” function has been set.	To turn the oven off turn the function selector knob to 0 .
		End with AUTO flashing and audible signal. End of the programmed cooking.	Press any programmer key to silence the audible signal OFF appears (see specific note).
		00.00 with bell symbol flashing and audible signal. End of the timer countdown.	Press any programmer key to silence the audible signal. The time appears.
		Start of the Pyrolysis cycle.	To increase the cycle length, up to max 3 hours, press key 2 of the programmer then key 6. To reduce to the minimum 1 hour 30 minutes press key 2 of the programmer and then key 5.
		P0.00 with P flashing. This appears after do.Lo , because the function selector knob has been moved from the Pyrolysis function to a cooking function. The temperature has dropped below 300°C. The key LED goes out and the door unlocks.	Turn the oven selector knob to 0 and repeat the operations to start the Pyrolysis cycle.
		P0.00 with P flashing. The oven selector knob has been moved to the Pyrolysis function (P).	To start the Pyrolysis cycle press key 3 of the programmer. To cancel the operation turn the oven function selector knob to 0 .
		AUTO flashing. End of the pyrolysis cycle. This message remains until the door unlocks.	Wait for the door to unlock.

PROGRAMMER MESSAGE		MESSAGE MEANING	WHAT TO DO
		<p>After the Pyrolysis cycle AUTO and P flashing. The door is unlocked and can be opened.</p> <p>During the Pyrolysis cycle AUTO and P flashing. The door has been opened and closed again. The Pyrolysis cycle is cancelled.</p>	<p>Turn the oven function selector knob to 0.</p> <p>Turn the oven selector knob to 0 and repeat the operations to start the Pyrolysis cycle.</p>
	door locked	<p>During the Pyrolysis cycle There has been a power cut.</p> <p>During the Pyrolysis cycle The oven function selector knob has been moved from the Pyrolysis function to a cooking function. The oven cavity temperature is higher than 300°C.</p> <p>During the Pyrolysis cycle The oven function selector knob has been moved to 0 to cancel the Pyrolysis cycle. The oven cavity temperature is higher than 300°C.</p> <p>During a cooking function Oven operation fault.</p>	<p>Turn the function selector knob to 0 and wait for the flashing 12.00 to appear. Then start the programmer, set the time and start the pyrolysis cycle again. If the display goes out see the specific chapter.</p> <p>Wait for the door to unlock. This happens automatically when the temperature inside the oven has dropped below 300°C (key LED goes out); P0.00 will appear with P flashing. Turn the oven selector knob to 0 and repeat the operations to start the Pyrolysis cycle.</p> <p>When the door unlocks, which happens automatically when the temperature inside the oven has dropped below 300°C (key LED goes out), the time will appear on the display again.</p> <p>Turn the function selector knob to 0 and wait for the oven to cool down so that the door unlocks. Then unplug the oven and call the After-Sales Service.</p>
		<p>door flashing and cooking symbol on. Waste of energy symbol. The oven door is open while cooking is taking place.</p>	<p>Close the oven door.</p>
		<p>door flashing, cooking symbol on and audible signal. Waste of energy symbol. The oven door has been open for 5 minutes while cooking is taking place.</p>	<p>Close the oven door and press any programmer key to switch the audible signal off.</p>

PROGRAMMER MESSAGE		MESSAGE MEANING	WHAT TO DO
		<i>door</i> . The oven function selector knob has been turned to the pyrolysis function with the oven door open.	Close the oven door and repeat the operations to start the Pyrolysis cycle.
		<i>door</i> flashing and audible signal. The function selector knob has been turned to the pyrolysis function for 5 minutes with the oven door open.	Close the oven door, press any programmer key to switch off the audible signal and repeat the operations to start the Pyrolysis cycle.
		<i>door</i> with AUTO flashing. The oven door has been opened with the Pyrolysis cycle in progress. The Pyrolysis cycle cancels.	Close the oven door and repeat the operations to start the Pyrolysis cycle.
		<i>door</i> with AUTO flashing and audible signal. The oven door has been opened for 5 minutes with the Pyrolysis cycle in progress. The Pyrolysis cycle is cancelled.	Close the oven door, press any programmer key to switch off the audible signal and repeat the operations to start the Pyrolysis cycle.
		Temperature sensor measurement error during the Pyrolysis cycle. This may be due to the Pyrolysis cycle being stopped and started again when it was quite a way through.	Turn the oven selector knob to 0 . Wait for at least 15 minutes before repeating the operations to start the Pyrolysis cycle. If the message is still given after several attempts call the After-Sales Service.
		Oven temperature sensor broken or not working properly. The cooling fan stays on in every cooking function and if the pyrolysis cycle is in progress the door stays locked.	Turn the function selector knob to 0 . The 30 minute countdown will start (see below).
		30 FO or 30 F1 . 30' countdown. If the selector knob is turned and then returned to 0 the count starts again from 30.	Wait for the countdown to stop. The fan stops and the door, if locked, unlocks. Unplug the oven and contact the After-Sales Service because the oven can no longer be used.
		Programmer with display off.	Turn the function selector knob to 0 , wait for the oven to cool down completely, switch the electricity off for a few seconds. If after this procedure the display is still off unplug the oven and contact the After-Sales Service. The oven must not be used.

HOW TO STOP THE PYROLYSIS CYCLE

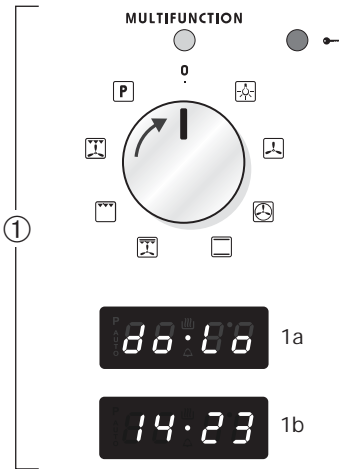

1. Turn the function selector to **0** (oven OFF)
 - *If the oven cavity temperature is higher than 300 °C*
 - 1a. **do•Lo** (door locked) appears steadily on the programmer display.
 - 1b. When the oven cavity temperature drops below 300°C:
 - the time appears on the programmer display again
 - the key pilot light goes out
 - the door unlocks
 - *If the oven cavity temperature is lower than 300 °C*
 - 1c. The time appears on the programmer display
 - 1d. After a technical time:
 - the key pilot light goes out
 - the door unlocks

ACCIDENTAL INTERRUPTION OF THE PYROLYSIS CYCLE

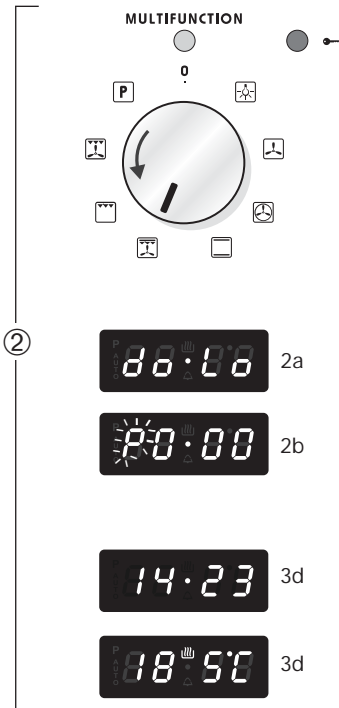

2. The function selector has been turned to any cooking function
 - *If the oven cavity temperature is higher than 300 °C*
 - 2a. **do•Lo** (door locked) appears steadily on the programmer display.
 - 2b. When the oven cavity temperature drops below 300°C:
 - **P0•00** appears with **P** flashing
 - the key pilot light goes out
 - the door unlocks
 - 3c. To reset normal conditions turn the function selector to **0** (oven OFF). The time appears on the programmer display.
 - *If the oven cavity temperature is lower than 300 °C*
 - 3d. The time appears on the programmer display, or the oven cavity temperature (**caution:** in this case the heating elements are working).
 - 3e. After a technical time:
 - the key pilot light goes out
 - the door unlocks
 - 3f. To reset normal conditions turn the function selector to **0** (oven OFF). The time appears on the programmer display.

WHAT TO DO WHEN THE PYROLYSIS CYCLE HAS FINISHED

- ① 
1. **P0.00** with **AUTO** flashing.
Wait for the oven to cool down and the door to unlock.
The pyrolytic cycle has finished. **P0.00** will remain until the door is unlocked.
The door remains locked until the cavity temperature has dropped below 300 °C.

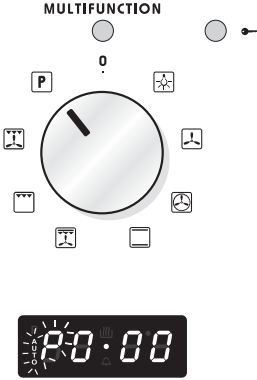
- ② 
2. The light with the key symbol goes out (when the temperature has dropped below 300 °C). **AUTO** and the letter **P** flash.
The door is unlocked and can be opened.
 3. Turn the function selector knob to **0** (oven OFF).
The time appears on the programmer display.

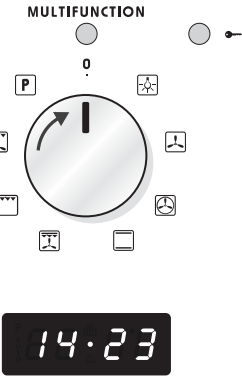
- ③ 
4. Wait for the oven to cool down completely.
 5. **Remove the pulverised dirt.**
Open the oven door and remove the residue of pulverised dirt inside the oven with a damp cloth.
- Before switching the oven on again in any function wait for the appliance to cool down completely.

ABNORMAL SITUATIONS AND/OR OPERATION PROBLEMS

during cooking or the pyrolysis cycle.

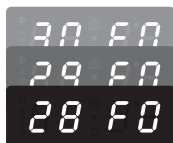

1. 30 F0 or 30 F1 appear during the cooking or pyrolysis cycle

Oven temperature sensor broken or not working properly. The cooling fan stays on and if the pyrolysis cycle is in progress the door remains locked.

What to do:

1. Turn the oven function selector to **0** (oven OFF). A 30 minute countdown will start. If the selector is turned and then returned to **0** the count will start again from 30.
2. Wait for the countdown to finish.
The fan switches off and the door, if locked, unlocks.
3. Disconnect the oven from the mains and contact the After-Sales Service Centre because the oven can no longer be used.

Caution: If the function selector is not turned to **0** (oven OFF), the cooling fan will continue to work and the oven door, if locked, remains locked.

2. do.Lo appears during the pyrolysis cycle

2a. There has been a black-out

The oven door is locked. The programmer is zeroed and the Pyrolysis cycle cancelled.

What to do:

1. Turn the oven function selector to **0** (oven OFF).
2. Wait for the oven cavity to cool down. When the temperature has dropped **12.00** will flash on the display
3. Start again and set the programmer time
4. Start the pyrolysis cycle again.

2b. The oven function selector has been moved from the Pyrolysis function to a cooking function.

The Pyrolysis cycle is cancelled.

What to do:

1. Wait for the door to unlock. This happens automatically when the temperature inside the oven has dropped below 300 °C; **P0.00** will appear with **P** flashing.
2. Turn the function selector to **0** (oven OFF),
- 3 Repeat the operations to start the pyrolysis cycle.



2c. The oven function selector has been moved to 0 (oven OFF) to cancel the Pyrolysis cycle.

What to do:

1. Wait for the door to unlock. This happens automatically when the temperature inside the oven has dropped below 300 °C.
2. The time appears and the oven can be used.



3. *do.Lo* appears during cooking

Oven not working properly.

What to do:

1. Turn the function selector to **0** (oven OFF),
2. Wait for the oven to cool down completely so that the door opens
3. Disconnect the oven from the mains.
4. Call the After-Sales Service Centre.



4. Display OFF

Oven not working properly.

What to do:

1. Turn the function selector to **0** (oven OFF)
2. Wait for the oven to cool down completely so that the door opens
3. Switch the oven off for a few seconds.

If after this procedure the display is still off:

4. Disconnect the oven from the mains.
5. Call the After-Sales Service Centre. The oven must not be used.

COOKING ADVICE

STERILIZATION

Sterilization of foods to be conserved, in full and hermetically sealed jars, is done in the following way:

- Turn the switch to position 
- Set the thermostat knob to position 175 °C and preheat the oven.
- Fill the grill pan with hot water.
- Set the jars into the grill pan making sure they do not touch each other and the door and set the thermostat knob to position 130 °C.

When sterilization has begun, that is, when the contents of the jars start to bubble, turn off the oven and let cool.

REGENERATION

Turn the switch to position  and set the temperature to 150 °C.



Bread becomes fragrant again if wet with a few drops of water and put into the oven for about 10 minutes.

ROASTING

To obtain classical roasting, it is necessary to remember:

- the pre-set temperature should be maintained
- that the cooking time depends on the quantity and the type of foods.

COOKING DIFFERENT DISHES AT THE SAME TIME

The MULTIFUNCTION oven at positions  and  of the function selector can cook various different foods at the same time. Fish, cakes and meat can be cooked together without the smells and flavours mixing.

The only precautions required are the following:

- The cooking temperatures must be as close as possible with a maximum difference of 20 - 25 °C between the different foods.
- Different dishes must be placed in the oven at different times according to the cooking time required for each one. This type of cooking obviously provides a considerable saving on time and energy.

USE OF THE GRILL

Turn the switch knob to position . Set the temperature if a temperature different from the pre-set one is required.

Leave to warm up for approximately 5 minutes with the door closed.

Introduce the food to be cooked, positioning the grill pan as close to the grill as possible. The dripping pan should be placed under the rack to catch the cooking juices and fats.

Always grill with the oven door closed.

COOKING WITH FAN GRILL

Grilling may be done by selecting grill+fan setting  with the function selector knob, because the hot air completely envelops the food that is to be cooked.

Set the temperature if a temperature different from the pre-set one is required.

Simply put the food on the shelf.

Put the drip tray under the shelf to collect the cooking juices.

Close the door and let the oven operate until grilling is done.

Adding a few dabs of butter before the end of the cooking time gives the golden “au gratin” effect.

Grilling with the oven door closed.

**ATTENTION: the oven door becomes very hot during operation.
Keep children away.**

IMPORTANT: In all cooking functions the oven must always be used with the door closed.

The electronic programmer is a device which groups together the following functions:

- 24 hours clock with illuminated display
- Timer (up to 23 hours and 59 minutes)
- Program for semi-automatic oven cooking.
- Program for automatic oven cooking
- Management of the cooking functions. The programmer can manage setting the temperature in the various cooking functions.
- Management of the pyrolysis function.

Description of the pushbuttons:



Timer (1)



Cooking time or pyrolysis time (2)



End of cooking time or allowance to start pyrolysis cycle (3)



Setting oven temperature (4)



Countdown of the figures of all the functions or of the temperature to be set (5)



Advance of the figures of all the functions or of the temperature to be set (6).

Description of the light symbols:

AUTO Indicates that a programme has been set



Indicates that the heating elements are working



Indicates that the timer is working

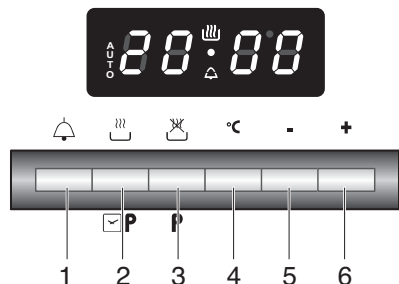

Fig. 4.1

ON SWITCHING ON FOR THE FIRST TIME OR AFTER A BLACK-OUT



After the appliance has been connected to the mains or after there has been a black-out the programmer must be activated so that it can work.

12:00 flashes on the display.

1. Press keys 2 and 3 at the same time.
The programmer starts to work.

SETTING THE TIME

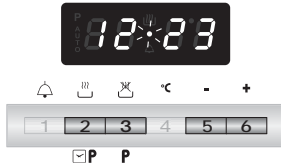

The programmer has an electronic clock with luminous figures which indicate hours and minutes.

Note: Setting the clock will zero any programmes in progress or set.

1. Press pushbuttons 2 and 3 at the same time.
2. Press pushbuttons 5 or 6 until the exact time is set. During this phase the dot between hours and minutes will flash on the display. If the plus or minus keys are kept pressed for a few seconds, the figures will scroll more quickly.

AUDIBLE SIGNAL

The intermittent audible signal, duration 30 seconds, sounds when the timer or semi-automatic or automatic cooking have reached the end of the time set. It also sounds to signal that the door is open (see oven use chapters).

To silence the audible signal press any of the programmer keys

SEMI-AUTOMATIC COOKING

Start immediate cooking or switch the oven off automatically after the programmed cooking time.



Setting

1. Set the cooking function by turning the oven selector to the function required.
2. The cooking temperature appears on the display. To change it proceed as described in the Setting the cooking chapter
3. Press pushbutton 2. **AUTO** starts to flash and **0.00** appears.
4. Press pushbuttons 5 or 6 to set the cooking time (cooking time in hours and minutes: set it to ten minutes less than the time required because the stored heat will complete the cooking).
5. On the display **AUTO** becomes steady and the cooking programme starts.

During cooking

6. During the cooking cycle, the display shows the oven temperature measured by the probe. Press key 2 to display the time remaining until the end of cooking. The cooking time and temperature can be varied at any time, as described above.

At the end of cooking

7. **End** appears on the display, **AUTO** flashes and the audible signal sounds. The cooking cycle has finished and the oven is OFF.
8. Press any programmer pushbutton to stop the audible signal.
9. **OFF** appears (oven OFF).
10. Turn the function selector to **0** (oven OFF).
11. The programmer display shows the time.

Note: At the end of the programme always turn the function selector knob to 0 (oven OFF).

AUTOMATIC COOKING

Start cooking at the programmed time and switch the oven off automatically after the programmed cooking time.

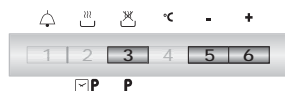
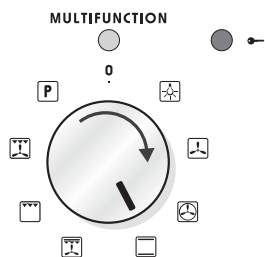

Setting

1. Set the cooking function by turning the oven selector to the function required.
2. The cooking temperature appears on the display. To change it proceed as described in the Setting the cooking chapter.
3. Press pushbutton 2. **AUTO** starts to flash and **0.00** appears.
4. Press pushbuttons 5 or 6 to set the cooking time (cooking time in hours and minutes: set it to ten minutes less than the time required because the stored heat will complete the cooking).
5. On the display **AUTO** becomes steady and the cooking programme starts.
6. Press pushbutton 3 (**AUTO** starts to flash).
7. Press pushbuttons 5 or 6 to set the time when the cooking should finish.
The values set must be correct; e.g. if it is 08:00 a cooking time of 3 hours, ending at 10:00, cannot be set. In this case the programmer automatically sets the end of cooking time for 11:00.
8. On the display **AUTO** becomes steady and the time appears again. The cooking symbol goes out.

Starting cooking

9. The pan symbol lights up. The oven switches on and the cooking cycle set starts.



During cooking

10. During the cooking cycle, the display shows the oven temperature measured by the probe.

Press key 2 to display the length of cooking set.

Press key 3 to display when the cooking will finish.

The cooking time, end of cooking time and cooking temperature can be varied at any time, as described above.



At the end of cooking

11. **End** appears on the display, **AUTO** flashes and the audible signal sounds.

The cooking cycle has finished and the oven is OFF.

13. Press any pushbutton to stop the audible signal.

14. **OFF** appears (oven OFF).

15. Turn the function selector to **0** (oven OFF).

16. The programmer display shows the time.



Note: At the end of the programme always turn the function selector knob to **0** (oven OFF).

CANCELLING A SET PROGRAMME

To cancel any programme just turn the function selector to **0** (oven OFF).

Note: if during a set programme the function selector is turned to **0** (oven OFF), **P** (pyrolysis) or **oven lighting**, the programme is cancelled.

EXAMPLES OF PROGRAMMING AUTOMATIC COOKING

② Time needed to cook the food (2 hours)

③ Time when the food to be cooked must be ready

① Time when cooking the food is programmed (08:00)

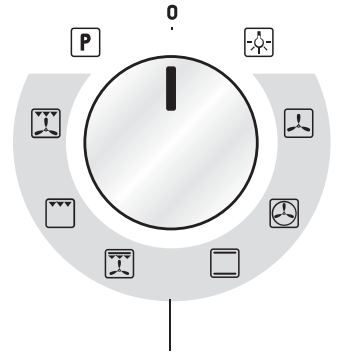
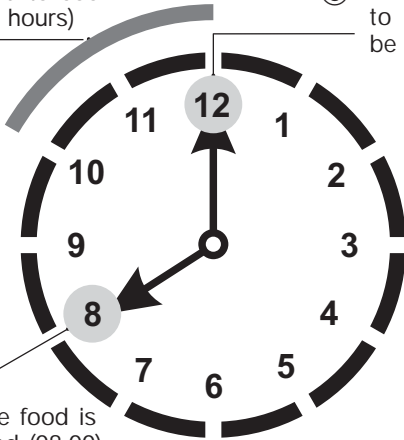

Programmable functions



GENERAL ADVICE

- Before you begin cleaning, you must ensure that the appliance is switched off.
- It is advisable to clean when the appliance is cold and especially when cleaning the enamelled parts.
- Avoid leaving alkaline or acidic substances (lemon juice, vinegar, etc.) on the surfaces.
- Avoid using cleaning products with a chlorine or acidic base.
- **Do not use a steam cleaner because the moisture can get into the appliance thus make it unsafe.**

WARNING

When correctly installed, your product meets all safety requirements laid down for this type of product category.

However special care should be taken around the rear or the underneath of the appliance as these areas are not designed or intended to be touched and may contain sharp or rough edges, that may cause injury.

Before any cleaning or maintenance operation, disconnect the oven from mains power supply.

ENAMELLED PARTS

- All of the enamelled parts must be washed only with a sponge and soapy water or with non-abrasive products.
- Dry preferably with a microfibre or soft cloth.

GLASS CONTROL PANEL

Clean using an appropriate product. Always dry thoroughly.

Do not use harsh abrasive cleaners or sharp metal scrapers to clean the control panel since they can scratch the surface, which may result in shattering of the glass.

STAINLESS STEEL SURFACES WITH ANTI-FINGERPRINT TREATMENT

CAUTION:

- The stainless steel front surfaces used in this oven are protected with a Special Lacquer to reduce finger-print marks.
- To avoid damaging this lacquer, do not clean the stainless steel with abrasive cleaners or abrasive cloths or scouring pads.

ONLY SOAP/WARM WATER MUST BE USED TO CLEAN THE STAINLESS STEEL SURFACES.

STAINLESS STEEL AND ALUMINIUM PARTS AND SILK-SCREEN PRINTED SURFACES

- Clean using an appropriate product. Always dry thoroughly.

IMPORTANT: these parts must be cleaned very carefully to avoid scratching and abrasion. You are advised to use a soft cloth and neutral soap.

INSIDE OF OVEN

- The oven should always be cleaned after use when it has cooled down.

The cavity should be cleaned using a mild detergent solution and warm water. Suitable proprietary chemical cleaners may be used after first consulting with the manufacturers recommendations and testing a small sample of the oven cavity. Abrasive cleaning agents or scouring pads/cloths should not be used on the cavity surface.

- **NOTE:** The manufacturers of this appliance will accept no responsibility for damage caused by chemical or abrasive cleaning.

Do not store flammable material in the oven.

GREASE FILTER

- Clean the filter after any cooking! The grease filter can be removed for cleaning and should be washed regularly in hot soapy water (fig. 2.2 at page 11).
- Always dry the filter properly before fitting it back into the oven.

CLEANING THE OVEN CAVITY

The oven has a specific "PYROLYSIS FUNCTION" which can clean the cavity by pulverising the residual cooking greases by high temperature.

Do not wait for the oven to be very greasy before performing this cleaning. It should not be performed after every cooking, either, but only when the level of dirt justifies it (on average 1 – 2 times a month depending on oven use).

To use this function see the specific chapters: "Selecting the functions – PYROLYSIS FUNCTION", "How to start the pyrolysis cycle", "Problems in starting and during the pyrolysis cycle", "How to stop the pyrolysis cycle" and "What to do when the pyrolysis cycle has finished".

Take the drip tray, shelf and grease filter (if fitted) out of the oven. They can be washed in the sink.

REPLACING THE OVEN LAMP

WARNING: Ensure the appliance is switched off before replacing the lamp to avoid the possibility of electric shock.

- Let the oven cavity and the heating elements to cool down;
- Switch off the electrical supply;
- Remove the protective cover **A** (fig. 5.1);
- Unscrew and replace the bulb **B** with a new one suitable for high temperatures (300 °C) having the following specifications:
230-240V 50 Hz, E14 and same power (check watt power as stamped in the bulb itself) of the replaced bulb.
- Refit the protective cover

NOTE: Oven bulb replacement is not covered by your guarantee

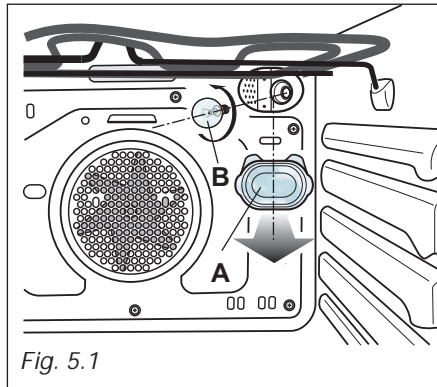

REMOVING THE OVEN DOOR

The oven door can easily be removed as follows:

- Open the door to the full extent (fig. 5.2a).
- Open the lever "A" completely on the left and right hinges (fig. 5.2b).
- Hold the door as shown in fig. 5.2.
- Gently close the door (fig. 5.2c) until left and right hinge levers "A" are hooked to part "B" of the door (fig. 5.2b).
- Withdraw the hinge hooks from their location following arrow "C" (fig. 5.2d).
- Rest the door on a soft surface.
- To replace the door, repeat the above steps in reverse order.

Do not use harsh abrasive cleaners or sharp metal scrapers to clean the oven door glass since they scratch the surface, which may result in shattering of the glass.

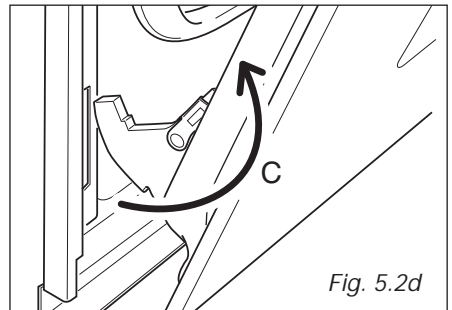
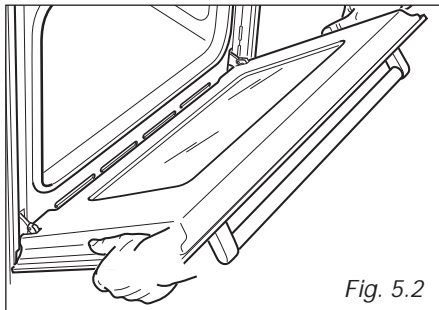
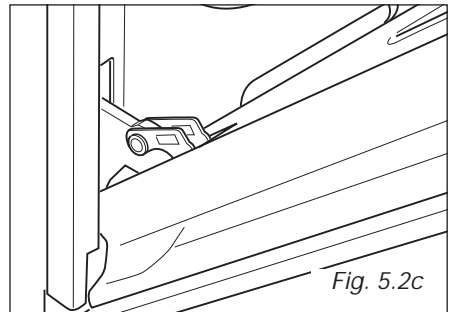
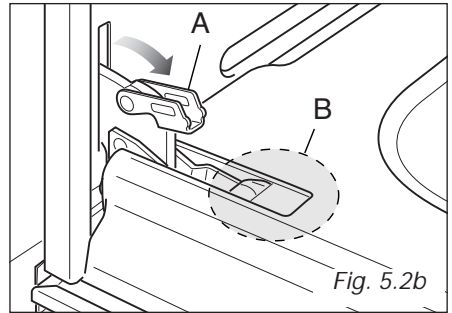
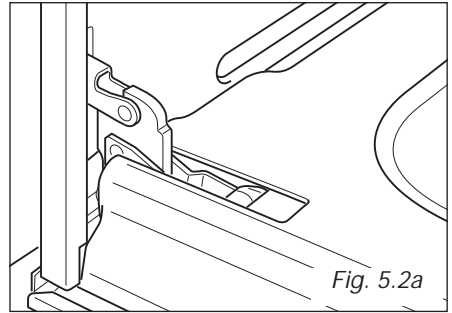

TROUBLESHOOTING:

If you experience a problem with your oven, check the following points before calling our Customer Service Centre for assistance.

1. The power is switched on.
2. The controls are switched on.
3. None semi-automatic or automatic cooking program has been selected.
4. Both the fuse and the mains fuse are intact.

Should you still require assistance please contact our Customer Service Centre for your nearest Authorised Delonghi Service Agent.



Descriptions and illustrations in this booklet are given as simply indicative. The manufacturer reserves the right, considering the characteristics of the models described here, at any time and without notice, to make eventual necessary modifications for their construction or for commercial needs.



Living innovation

cod. 1103197 - B2