



INSTALLATION and SERVICE INSTRUCTIONS
USE and CARE INSTRUCTIONS

DE 926 GWF
DUAL FUEL COOKER



distributed by
DèLonghi
Pty Ltd

Dear Customer,

Thank you for having purchased and given your preference to our product.

The safety precautions and recommendations reported below are for your own safety and that of others. They will also provide a means by which to make full use of the features offered by your appliance.

Please keep this booklet in a safe place. It may be useful in future, either to yourself or to others in the event that doubts should arise relating to its operation.

This appliance must be used only for the task it has explicitly been designed for, that is for cooking foodstuffs. Any other form of usage is to be considered as inappropriate and therefore dangerous.

The manufacturer declines all responsibility in the event of damage caused by improper, incorrect or illogical use of the appliance or be faulty installation.

Important:

This appliance is designed and manufactured solely for the cooking of domestic (household) food and is not suitable for any non domestic application and therefore should not be used in a commercial environment.

The appliance guarantee will be void if the appliance is used within a non domestic environment i.e. a semi commercial, commercial or communal environment.

PRODUCT LABEL

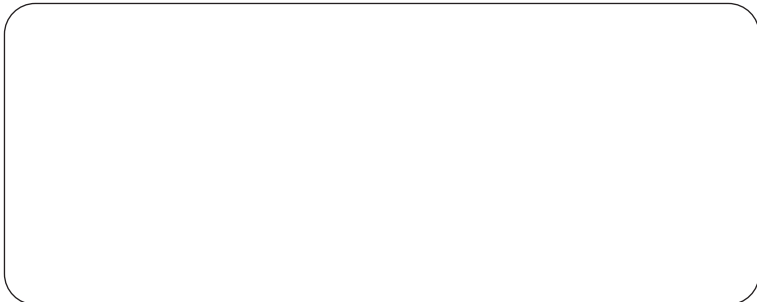

USING THE OVEN FOR THE FIRST TIME

You are advised to carry out the following operations:

- Furnish the interior of the oven.
- Switch the empty oven ON at maximum temperature for about two hours to eliminate traces of grease and smell from the components.
- Disconnect the appliance from the electric power supply and clean the interior of the oven with a cloth soaked in water and neutral detergent and dry thoroughly.

IMPORTANT PRECAUTIONS AND RECOMMENDATIONS FOR USE OF ELECTRICAL APPLIANCES

Use of any electrical appliance implies the necessity to follow a series of fundamental rules. In particular:

- Never touch the appliance with wet hands or feet;
- do not operate the appliance barefooted;
- The appliance is not intended for use by young children or infirm persons without supervision
- Young children should be supervised to ensure they do not play with the appliance

The manufacturer cannot be held responsible for any damages caused by improper, incorrect or illogical use of the appliance.

This cooker has been designed and constructed in accordance with the following codes and specifications:

AGA101 (AS 4551)	Approval Requirements for Domestic Gas cooking appliances
AS/NZS 60335-1	General Requirements for Domestic electrical appliances
AS/NZS 60335-2-6	Particular Requirements for Domestic electrical cooking appliances
AS/NSZ 1044	Electromagnetic Compatibility Requirements.

IMPORTANT PRECAUTIONS AND RECOMMENDATIONS

After having unpacked the appliance, check to ensure that it is not damaged.

In case of doubt, do not use it and consult your supplier or a professionally qualified technician.

Packing elements (i.e. plastic bags, polystyrene foam, nails, packing straps, etc.) should not be left around within easy reach of children, as these may cause serious injuries.

- Do not attempt to modify the technical characteristics of the appliance as this may become dangerous to use.
- Do not carry out cleaning or maintenance operations on the appliance without having previously disconnected it from the electric power supply.
- After use, ensure that the knobs are in the off position.
- The appliance is not intended for use by young children or infirm persons unless they have been adequately supervised by a responsible person to ensure that they can use the appliance safely.
- During and after use of the appliance, certain parts will become very hot. Do not touch hot parts. Care should be taken to avoid touching heating elements inside the ovens.
- Keep children away from the appliance when it is in use.
- Young children should be supervised to ensure that they do not play with the appliance.
- Some appliances are supplied with a protective film on steel and aluminium parts. This film must be removed before using the appliance.
- Make sure that electrical cables connecting other appliances in the proximity of the cooker cannot come into contact with the hob or become entrapped in the oven doors.
- Do not line the oven walls with aluminium foil. Do not place baking trays or the drip tray on the base of the oven chamber.
- **WARNING** When correctly installed, your product meets all safety requirements laid down for this type of product category. However special care should be taken around the rear or the underneath of the appliance as these areas are not designed or intended to be touched and may contain sharp or rough edges, that may cause injury.
- **Fire risk!** Do not store flammable material in the ovens and in the storage compartment.
- Always use oven gloves when removing the shelves and food trays from the oven whilst hot.
- Do not hang towels, dishcloths or other items on the appliance or its handle – as this could be a fire hazard.
- Clean the oven regularly and do not allow fat or oils to build up in the oven base or tray. Remove spillages as soon as they occur.
- Do not stand on the open oven door/s.
- Always stand back from the appliance when opening the oven door to allow steam and hot air to escape before removing the food.
- This appliance is for domestic use only.
- Safe food handling: leave food in the oven for as short a time as possible before and after cooking. This is to avoid contamination by organisms which may cause food poisoning. Take particular care during warmer weather.
- The manufacturer declines all liability for injury to persons or damage to property caused by incorrect or improper use of the appliance.
- **WARNING: Taking care NOT to lift the cooker by the door handle/s.**
- **IMPORTANT NOTE: This appliance shall not be used as a space heater, especially if installed in marine craft or caravans.**

INSTALLATION

CAUTION:

- This appliance must be installed in accordance with these installation instructions.
- This appliance shall only be serviced by authorized personnel.
- This appliance is to be installed only by an authorised person.
- Incorrect installation, for which the manufacturer accepts no responsibility, may cause personal injury or damage.
- Always disconnect the cooker from mains power supply before carrying out any maintenance operations or repairs.
- In the room where the cooker is installed, there must be enough air to allow the gas to burn correctly, according to the current local regulations.

ELECTRICAL REQUIREMENTS

- The appliance must be connected to the mains checking that the voltage corresponds to the value given in the rating plate and that the electrical cable sections can withstand the load specified on the plate.
- The appliance must be connected directly to the mains placing a two pole switch with minimum opening between the contacts of 3 mm between the appliance and the mains.
- The power supply cable must not touch the hot parts and must be positioned so that it does not exceed 50°C above ambient.
- Once the appliance has been installed, the switch must always be accessible.
- **If the supply cord is damaged it must be replaced by the manufacturer or its Service Agent or a similarly qualified person in order to avoid a hazard.**

WARNING: This cooker must be connected to electrical supply using V105 insulated cable.

N.B. The connection of the appliance to earth is mandatory.

If the installation requires alterations to the domestic electrical system call a qualified electrician.

He should also check that the domestic electrical system is suitable for the power drawn by the appliance.

Appliance power rating: 230 V~ 4200 W (18.2 A)
 240 V~ 4550 W (18.9 A)

CLEARANCES

Installation clearances and protection of combustible surfaces shall comply with the current local regulations eg. AG 601 (AS 5601) Gas Installations code.
Installation shall comply with the dimension in Fig. 1a bearing in mind that.

Overhead Clearances

In no case shall the clearances between the highest part of the cooker be less than 600mm or for an overhead exhaust fan 750mm. All other downward facing combustible surfaces less than 600mm above the cooker surface shall be protected for the full width of the cooking surface in accordance with the standards noted above. In no case shall the clearance be less than 450mm.

Rear and Side Clearances

Where the dimensions from the periphery of the nearest burner to any vertical combustible surface is less than 200mm the surface shall be protected in accordance with the standards to a height of not less than 150mm above the cooking surface for the full width or depth of the cooking surface

Where the dimensions from the periphery of the nearest burner to any horizontal combustible surface is less than 200 mm, the horizontal surface shall be greater than 10 mm below the surface of the hob, or the horizontal surface requirement above.

Protection of combustible surfaces.

The standards above specify that where required protection shall ensure that the surface temperature of the combustible surface does not exceed 65°C above room temperature.

If the cooker is located on a pedestal it is necessary to provide safety measures to prevent falling out.

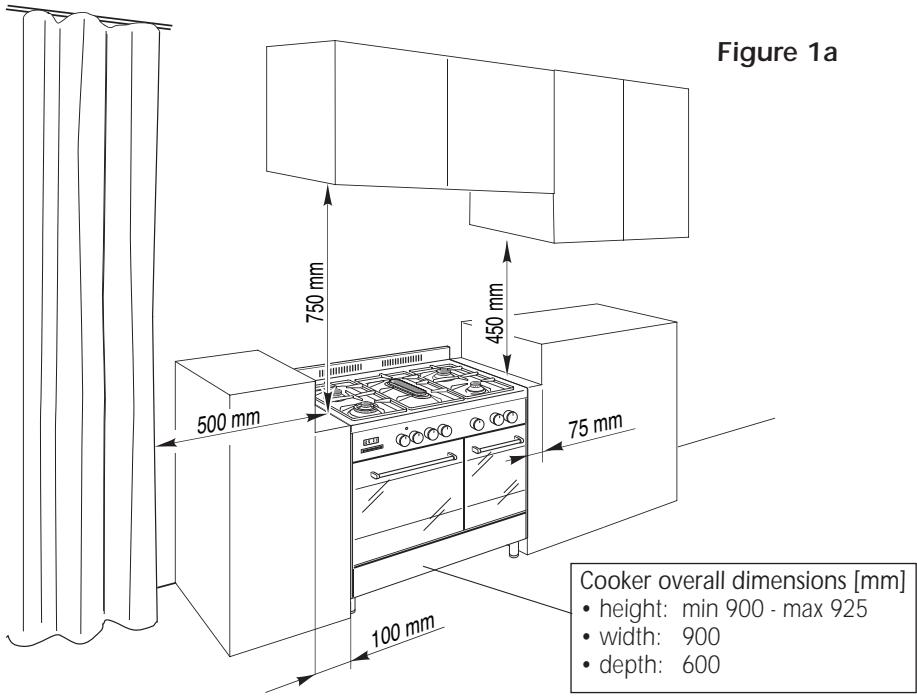

GAS AND ELECTRIC CONNECTION

Figure 1b

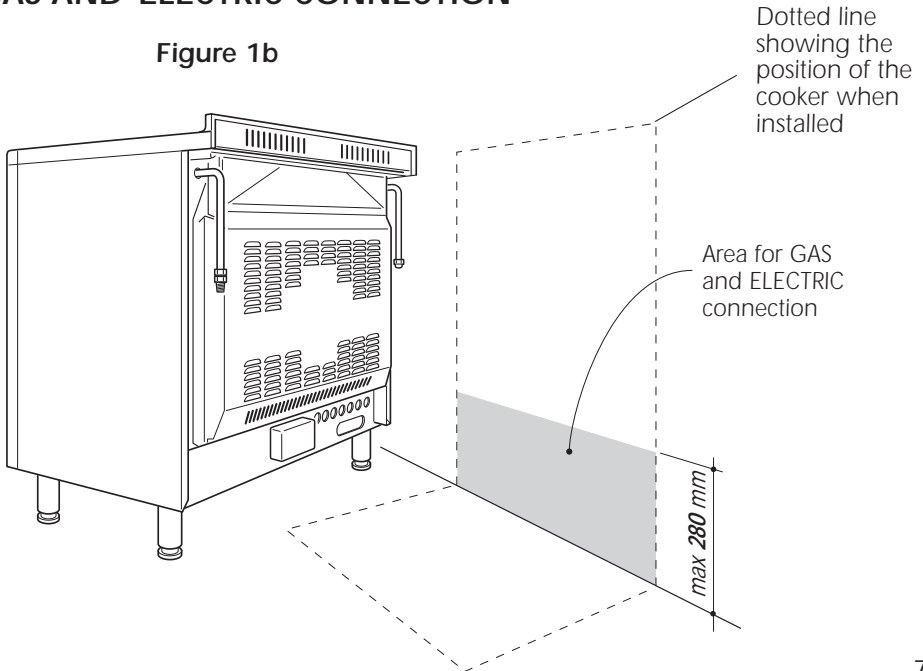

FITTING THE ADJUSTABLE FEET

The adjustable feet must be fitted to the base of the cooker before use.

Rest the rear of the cooker on a piece of the polystyrene packaging exposing the base for the fitting of the feet.

Fit the 4 legs by screwing them tight into the support base as shown in figure 3.

Figure 2

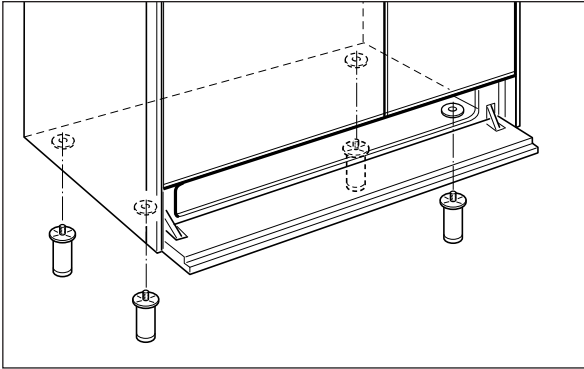
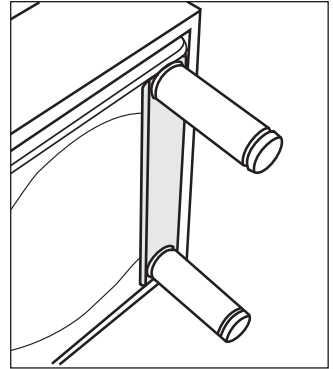

Figure 3



LEVELLING THE COOKER

The cooker may be levelled by screwing the lower ends of the feet IN or OUT (fig. 4).

Figure 4

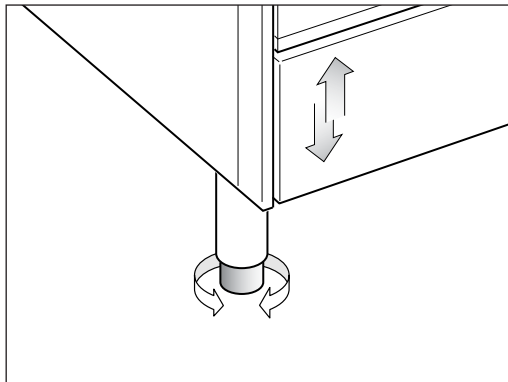

MOVING THE COOKER

WARNING

When raising cooker to upright position always ensure two people carry out this manoeuvre to prevent damage to the adjustable feet (fig. 5).

Figure 5

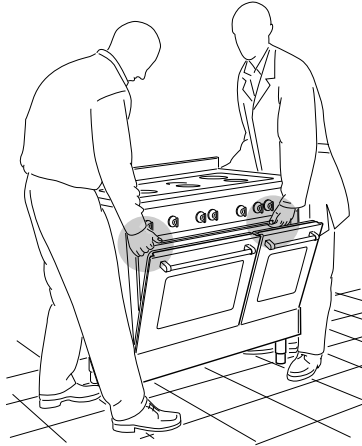

WARNING

Be careful: do not lift the cooker by the door handle when raising to the upright position (fig. 6).

Figure 6

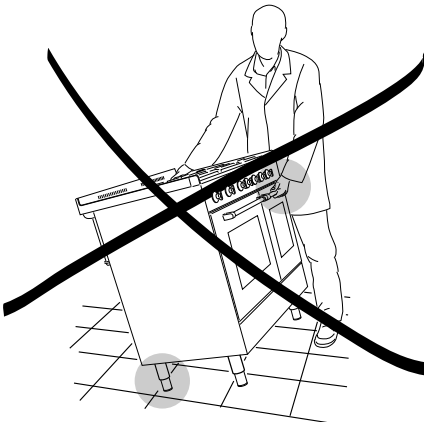

WARNING

When moving cooker to its final position **DO NOT DRAG** (fig. 7). Lift feet clear of floor (fig. 5).

Figure 7

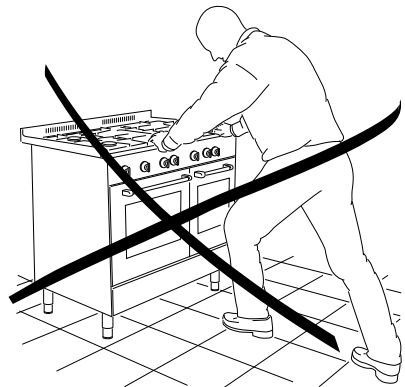

ANTI-TILT BRACKET

Important!

To restrain the appliance and prevent it tipping accidentally, fit a bracket to its rear to fix it securely to the wall. Make sure you also fit the supplied lock pin to the anti-tilt bracket.

To fit the anti-tilt bracket:

1. After you have located where the cooker is to be positioned, mark on the wall the place where the two screws of the anti-tilt bracket have to be fitted. Please follow the indications given in Fig. 8a.

2. Drill two 8 mm diameter holes in the wall and insert the plastic plugs supplied.

Important!

Before drilling the holes, check that you will not damage any pipes or electrical wires.

3. Loosely attach the anti-tilt bracket with the two screws supplied.
4. Move the cooker to the wall and adjust the height of the anti-tilt bracket so that it can engage in the slot on the cookers back, as shown in Fig. 8a.
5. Tighten the screws attaching the anti-tilt bracket.
6. Push the cooker against the wall so that the anti-tilt bracket is fully inserted in the slot on the cooker's back.
7. Access the bracket and fit the lock pin:

- Open the pivoting panel (Fig. 8b).
- Fit the lock pin through the bracket, as shown (Fig. 8c).
- Close the pivoting panel.

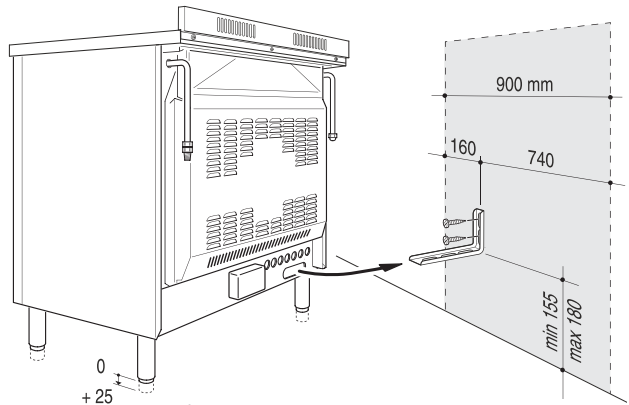

Figure 8a Fitting the anti-tilt bracket

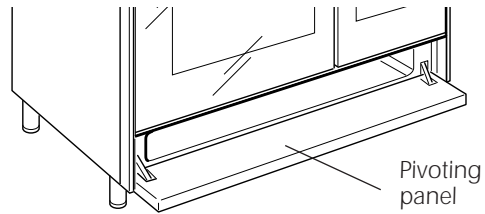

Figure 8b Opening the pivoting panel

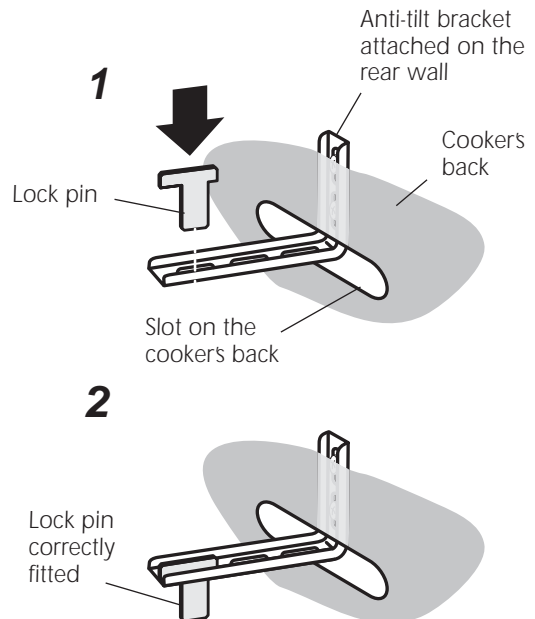

Figure 8c Fitting the lock pin through the bracket

BACKGUARD

Before installing the cooker, assemble the backguard "C" (fig. 9).

- The backguard "C" can be found packed at the rear of the cooker.
- Before assembling remove any protective film/adhesive tape.
- Remove the two spacers "A" and the screw "B" from the rear of the cooktop.
- Assemble the backguard as shown in figure 9 and fix it by screwing the central screw "B" and the spacers "A".

Figure 9

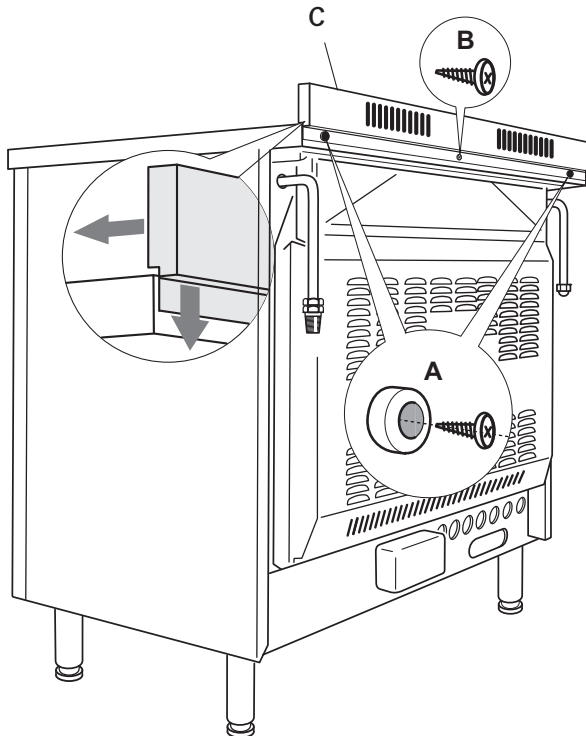

GAS SUPPLY:

- The connection must be performed by an authorised person according to the relevant standards.
- Before connecting the appliance to the gas main, mount the brass conical adaptor onto the gas inlet pipe, upon which the gasket has been placed (figures 10-11).
Conical adaptor and gasket are supplied with the appliance (packed with conversion kit for use with Natural Gas or ULPG).
- This appliance is suitable for use with Natural Gas or ULPG. (Check the "gas type" sticker attached to the appliance).
- For Natural Gas models the gas supply is connected to the pressure regulator which is supplied with the appliance (fig. 11). Adjust the regulator to obtain a test point pressure of 1 kPa with the two semi-rapid (SR) burners operating at the maximum.
- For ULPG models the gas supply is connected to the test point adaptor which is supplied with the appliance (fig. 10) and ensure that the supply pressure is regulated to 2.75 kPa.
- The connection must be made at the rear of appliance (left or right); the pipe does not cross the cooker.
- The inlet not used must be closed off with the cap and sealing gasket supplied.
- **IMPORTANT:** Use two spanners to tighten or loosen the connecting pipe (fig. 13)

Figure 10

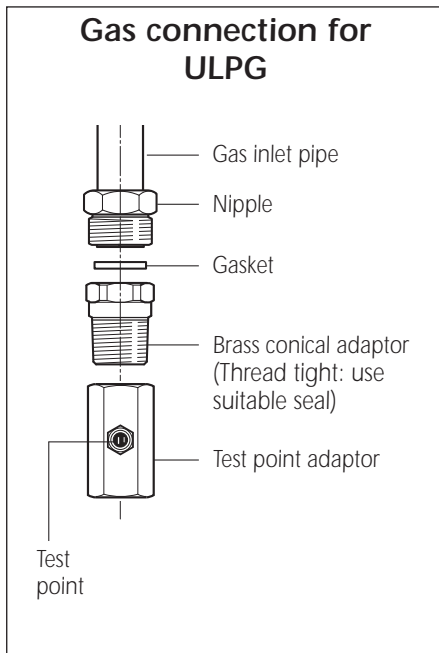
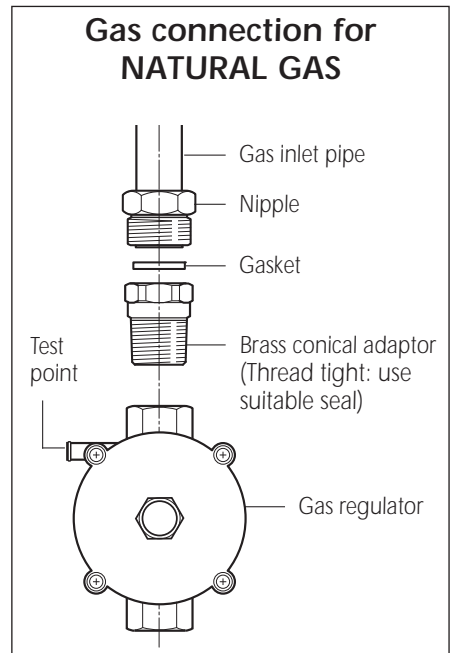

Figure 11



1. After connecting the gas supply, check the piping and connections for leaks using a soap and water solution. The presence of bubbles indicates a leak, tighten or replace connections as appropriate.
Warning: Do not use any naked flame to check for leaks.
2. Adjust the test point pressure or supply pressure to the value which is appropriate for the gas type.
3. The operation of the appliance must be tested when installation is completed.
4. Turn on the appliance gas controls and light each burner individually and in combination. Check for a well defined blue flame without any yellow tipping. If any abnormality is evident then check that the burner cap is located properly and the injector nipple is aligned correctly.
5. Check the minimum burner setting by quickly rotating the gas control knob from the maximum to the minimum position, the flame must not go out. If adjustment is required carry out the "minimum burner setting adjustment" procedure described
6. If satisfactory performance cannot be obtained, the installer shall check the installation and notify the local gas supply authority for a gas supply problem, or if it is an appliance problem, our Customer Service Centre should be called to obtain the nearest authorized Delonghi Service Agent.

WARNING, This appliance **IS NOT SUITABLE** for installation with a hose assembly.

Figure 12

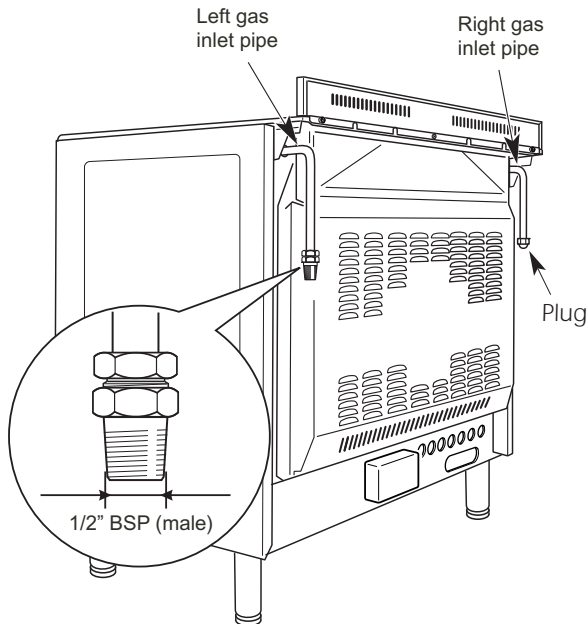
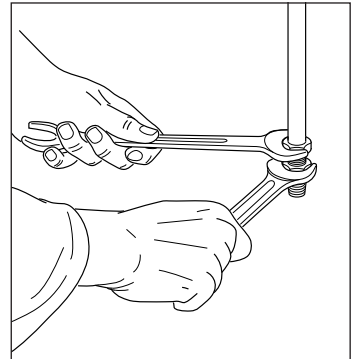

Figure 13



CONVERSION PROCEDURE (to convert to Natural gas or to ULPG)

REPLACING THE INJECTORS

This appliance is suitable for use with Natural gas or ULPG (check the “gas type” sticker attached to the appliance). A label stating the type of gas used after replacing the injectors must be attached at the rear of the appliance, in proximity of the gas inlet connection. The nominal gas consumption and injector size details are provided in table at page 16.

To replace the injectors proceed as follows:

- Remove pan supports and burners from the cooktop.
- Using a spanner, remove the injector J (figs. 14a, 14b) and replace it with one according to the gas type (see following tables - page 16).
- Affix to the rear of the appliance, in proximity of the gas inlet connections, the warning label (supplied with the conversion kit) stating that the cooker has been converted for use with ULPG / Natural gas.

IMPORTANT

- If the cooker is suitable for use with Natural gas and must be converted for use with ULPG, before connecting to gas main remove the appliance gas regulator and replace with test point adaptor (see figs. 10-11)
- If the cooker is suitable for use with ULPG and must be converted for use with Natural gas, before connecting to the gas main remove the appliance test point adaptor and replace with gas regulator (see figs. 10-11).

NOTE:

Gas regulator and test point adaptor are supplied with the appliance (packed with conversion kit)

The burners are designed so that regulation of primary air is not required.

Figure 14a

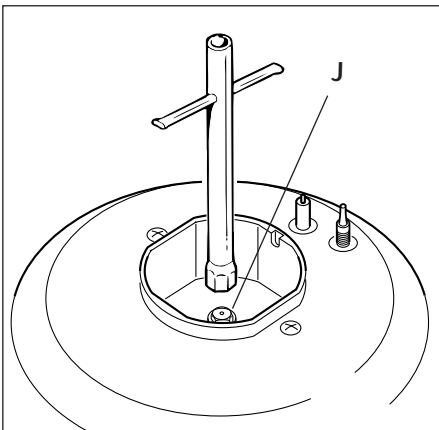
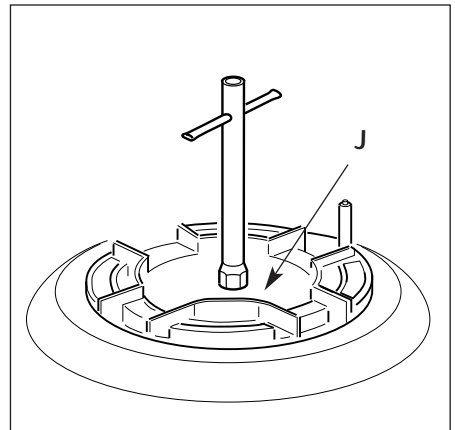

Figure 14b



MINIMUM BURNER SETTING ADJUSTMENT

Check whether the flame spreads to all burner ports when the burner is lit with the gas tap set to the minimum position. If some ports do not light, increase the minimum gas rate setting.

Check whether the burner remains lit even when the gas tap is turned quickly from the maximum to the minimum position. If the burner does not remain lit, increase the minimum gas rate setting.

The procedure for adjusting the minimum gas rate setting is described below.

- Turn on the burner
- Turn the tap to the MINIMUM position
- Take off the knob
- With a small flat screwdriver turn the screw "F" (fig. 15) to the correct regulation.

Normally for ULPG, the regulation screw is tightened up.

Figure 15

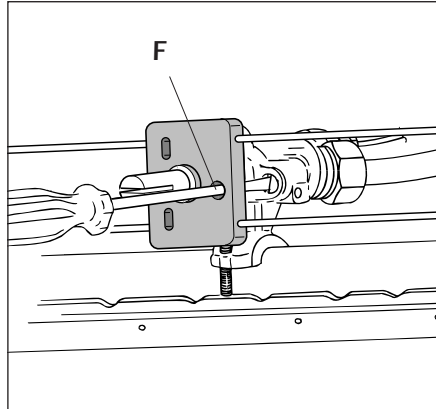

TABLE FOR THE CHOICE OF THE INJECTORS

	Natural gas		ULPG	
Test Point Pressure [kPa]	1.0		2.75	
BURNER	Injector Orifice Dia.	Gas Consumption	Injector Orifice Dia.	Gas Consumption
	[mm]	[MJ/h]	[mm]	[MJ/h]
Auxiliary (A)	0.85	3.60	0.53	3.60
Semi-rapid (SR)	1.12	6.30	0.70	6.30
Triple ring (TC)	1.65	13.30	0.95	11.90
Fish burner (FB)	1.45	10.60	0.91	10.60

LUBRICATION OF THE GAS TAPS

If the gas tap becomes stiff, it is necessary to dismantle it carefully and clean it with petroleum spirit. Specialist high temperature resistant grease should be used to lubricate the tap before replacing.

The operations must be carried out by an authorised person/service agent.

Figure 16

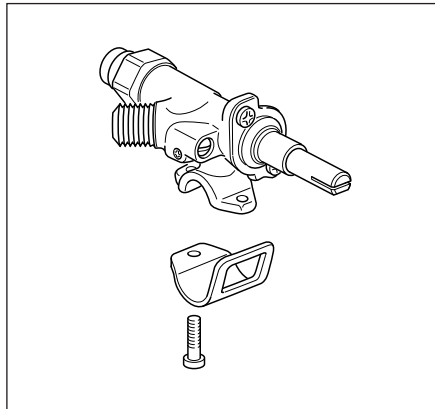



USE and CARE

CAUTION:

- This appliance must be used only for the task it has explicitly been designed for, that is for domestic cooking of foodstuffs. Any other form of usage is to be considered as inappropriate and therefore dangerous.
- Do NOT place combustible materials or products on this appliance at any time.
- Do NOT spray aerosols in the vicinity of this appliance while it is in use.

USING THE RIGHT CONVENTIONAL OVEN FOR THE FIRST TIME

- Clean the inside of the conventional oven with a cloth soaked in water and neutral detergent and dry thoroughly.
- Slide in the wire racks on the oven walls as in Fig. 17.
- Position the shelf and tray as per Fig. 18.
- To eliminate traces of grease in manufacture it is necessary to pre-heat the oven at the maximum temperature.
 - For 60 minutes in the  position, and for another 15 minutes in the  position.

WARNING: The door is hot, use the handle.

Figure 17

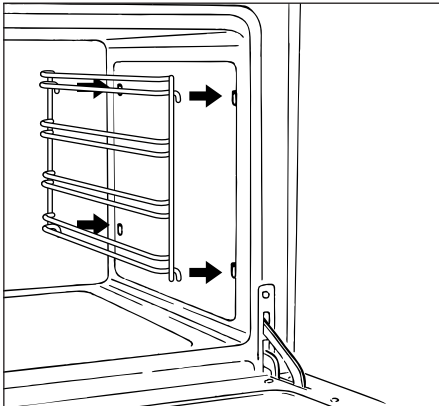
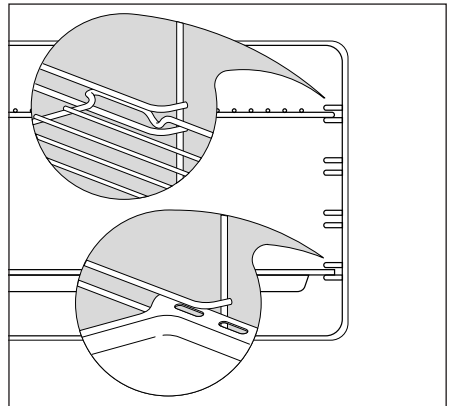





Figure 18



SLIDING SHELVES (LEFT MAIN OVEN ONLY)

- They facilitate the insertion and removal shelves during cooking. These shelves support all accessories and the dishwasher safe.
- The shelves block when pulled to the maximum position.
- The sliding shelves can be removed easily by lifting slightly and detaching them from the oven walls.

USING THE LEFT MULTIFUNCTION MAIN OVEN FOR THE FIRST TIME

- Slide off the sliding shelves and the catalytic liners to the oven wall as in Fig. 19.
- Clean the inside of the oven with a cloth soaked in water and neutral detergent and dry thoroughly.
- Slide in the catalytic liners and sliding shelves on the oven wall as in Fig. 19.
- Slide in the grease filter on the back of the oven as in Fig. 21.
- Position the tray and the shelf as per Fig. 20.
- To eliminate traces of grease in manufacture it is necessary to pre-heat the oven at the maximum temperature.
 - For 60 minutes in the  position, for 30 minutes in the  position and for another 15 minutes in the  position.

WARNING: The door is hot, use the handle.

Figure 19

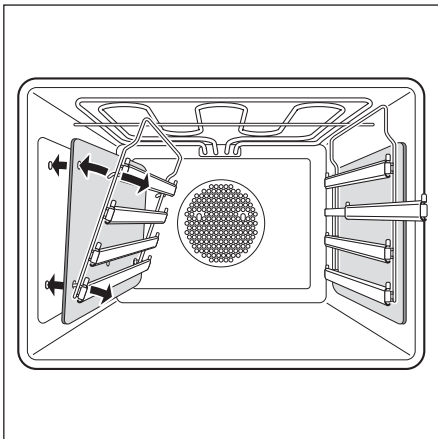
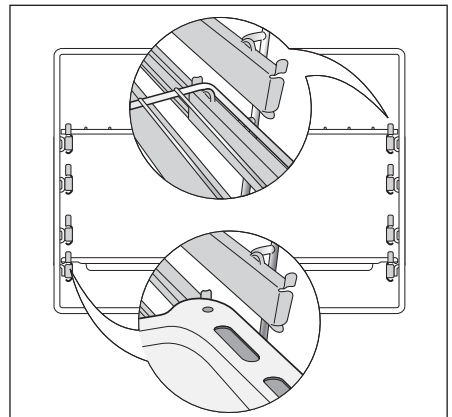

Figure 20



GREASE FILTER

- A special screen is provided at the back of the multifunction main oven to catch grease particles, mainly when meat is being roasted (fig. 21).
- When baking pastry etc. this filter should be removed.
- Always clean the filter after cooking as any solid residues on it might adversely affect the oven performance.

Figure 21

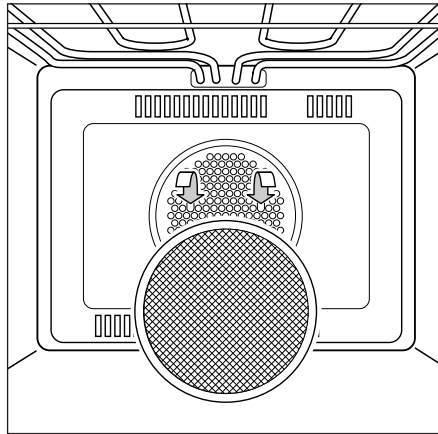

GAS HOB

Figure 22

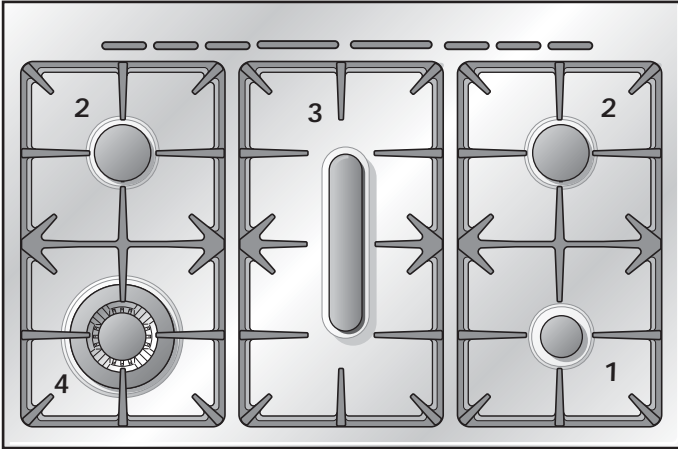

GAS BURNERS



	Natural Gas MJ/h	ULPG MJ/h
1. Auxiliary burner (A)	3.6	3.6
2. Semi-rapid burner (SR)	6.3	6.3
3. Fish burner (FB)	10.6	10.6
4. Triple ring burner (TC)	13.3	11.9

LIGHTING GAS BURNERS

FITTED WITH SAFETY VALVE DEVICE AND ELECTRONIC IGNITION

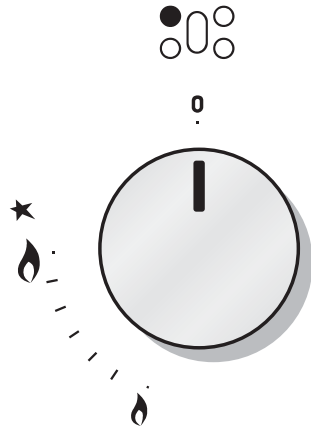
Figure 23



- Check that the electricity is switched on to allow spark ignition.
- Make sure that all controls are turned to zero.
- The gas flow to the burner is controlled by taps with safety cutout device. If the burner flame should go out, the safety cut-off valve will automatically stop the gas flow. The switch for the electric ignition is incorporated in the knobs.
- You control the flow by turning the knob indicator to line up with the following symbols:
 - Symbol  : tap closed (burner off)
 - Symbol  : High (maximum)
 - Symbol  : Low (minimum)
- To ignite automatically, push the required knob down and turn it to maximum, keeping the knob down until the burner lights. When the flame is lit, wait for about ten second with the knob down (safety cut-off activation delay).
- You can control the temperature by the knob to “High” (maximum) from “Low” (minimum).
- To switch off, turn the knob clockwise until you hear the safety click.
- Note that, if you are using a burner at the minimum setting, you turn the knob clockwise past the maximum setting before reaching the off position.
- Whenever the lighting of the burners is difficult due to peculiar conditions of the gas features or supply, it is advised to repeat the ignition with the knob on “minimum” position.
- If when lighting any of the burners an abnormal flame appears, switch the burner off and relight using the minimum setting.
- If the flame is still not correct, turn the burner off and call our Customer Service center for your nearest Authorized Delonghi Service Agent.
- In the case of a mains failure light the burner with a match or lighted taper.

CHOICE OF BURNER

The burner must be chosen according to the diameter of the pans and energy required.

For optimum efficiency use a wok or pan no smaller than 230 mm diameter.

Figure 24

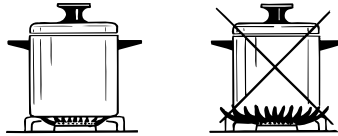

do not use pans with concave or convex bases

Burners	Pan diameter
Auxiliary	*12 - 14 cm
Semi-rapid	16 - 24 cm
Triple ring	26 - 28 cm
Fish-burner	from 12x30 to 18x40 cm
Wok	max 36 cm

(*) with grill for small cookware: minimum diameter 6 cm.

Saucepans with handles which are excessively heavy, in relationship to the weight of the pan, are safer as they are less likely to tip.

Pans which are positioned centrally on burners are more stable than those which are offset.

It is far safer to position the pan handles in such a way that they cannot be accidentally knocked.

When deep fat frying fill the pan only one third full of oil.

DO NOT cover the pan with a lid and **DO NOT** leave the pan unattended. In the unfortunate event of a fire, leave the pan where it is and turn off all controls.

Place a damp cloth or correct fitting lid over the pan to smother the flames.

DO NOT use water on the fire.

Leave the pan to cool for at least 30 minutes.

CORRECT USE OF TRIPLE-RING BURNER

- The flat-bottomed pans are to be placed directly onto the pan-support.
- To use the WOK, you must place the wok stand in the **CORRECT** position as shown in Fig. 25a-25b.

IMPORTANT:

The special grille for wok pans (fig. 25b) **MUST BE PLACED ONLY** over the pan-rest for the triple-ring burner.

Figure 25a

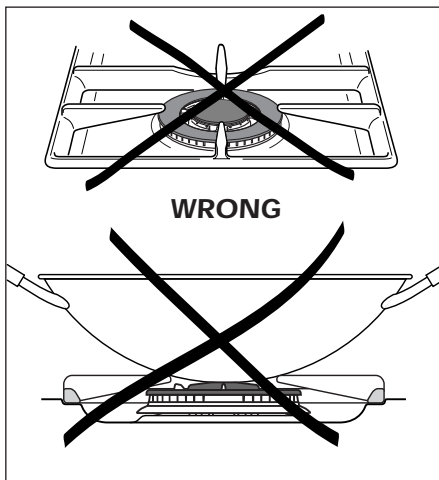

Figure 25b

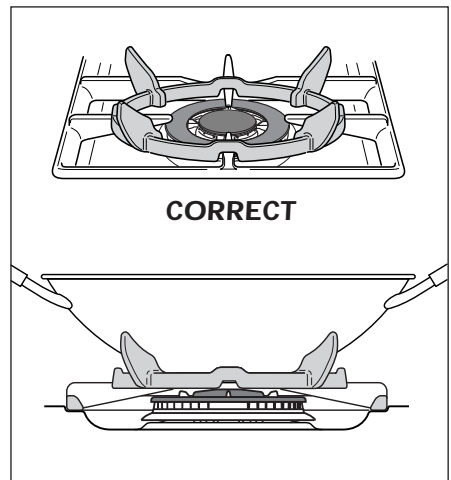
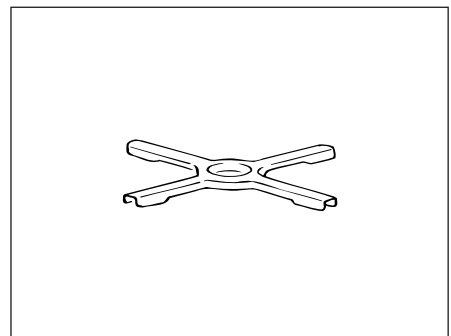

Figure 25c

GRATE FOR SMALL PANS

(fig. 25c)

This grate is to be placed on top of the (smaller) auxiliary burner when using small diameter pans, in order to prevent them from tipping over.



CONTROL PANEL

Figure 26

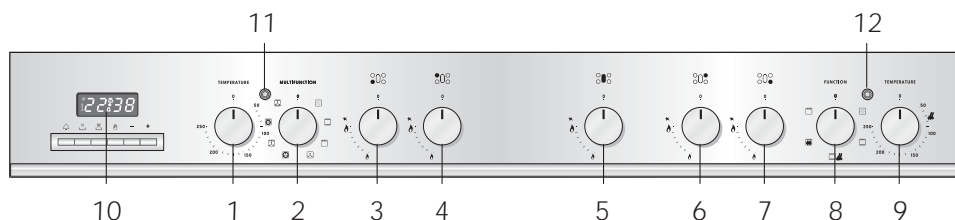

Controls description

1. Multifunction main oven thermostat knob
2. Multifunction main oven switch knob
3. Front left burner control knob
4. Rear left burner control knob
5. Fish burner control knob
6. Rear right burner control knob
7. Front right burner control knob
8. Conventional oven switch knob
9. Conventional oven thermostat knob
10. Electronic programmer (main oven only)



Pilot lamp:

11. Main oven thermostat indicator light
12. Conventional oven thermostat indicator light

Please note: This appliance incorporates a safety cooling fan which you will hear operating whenever the oven or grill are in use. This fan is to reduce the external temperature of the appliance and cool the internal components.

LEFT MULTIFUNCTION MAIN OVEN

GENERAL FEATURES

With your new Multi-Function oven it is possible to cook a variety of food using the 6 different cooking functions.

These 6 functions are obtained using a combination of the 4 different heating elements plus a defrost function using the fan only.

OPERATING PRINCIPLES

Heating and cooking in the **MULTI-FUNCTION** oven are obtained in the following ways:

a. by normal convection

The heat is produced by the upper and lower heating elements.

b. by forced convection

The fan draws in air contained within the oven housing at the rear of the oven and forces it over the circular heating element. The hot air envelops the food in the oven giving faster and more even cooking before it is drawn back into the housing to repeat the cycle. It is possible to cook several dishes simultaneously due to the even distribution of heat within the oven.

c. by forced semi-convection

The heat produced by the top and bottom heating elements is distributed throughout the oven by the fan.

d. by radiant heat

The food is grilled by the infra red grill element.

e. by radiant heat and ventilation

The food is grilled by the grill element is distributed throughout the oven

f. by ventilation

The food is defrosted by using the fan only function without heat.

WARNING:

The door is hot, use the handle.

During use the appliance becomes hot. Care should be taken to avoid touching heating elements inside the oven.



GRILLING

The infrared grill element at the top of the oven comes on. The heat is dispersed by radiation. Use with the **oven door closed** and the thermostat knob to position **225 °C** for max 15 minutes, then to position **175 °C**.

For cooking hints, see the chapter "USE OF THE GRILL".

Ideal for:

Intense grilling, browning, cooking au gratin and toasting etc.

It is recommended that you do not grill for longer than 30 minutes at any one time.

Attention: the oven door becomes very hot during operation.

Keep children away.



DEFROST

Only the oven fan comes on. Use with the thermostat knob set to "0" - other temperature have no effect. The food is thawed by ventilation without heating.

Ideal for:

Quick thawing of frozen foods; one kg requires approximately 1 hour.

Thawing times vary according to the quantity and type of food to be thawed.



FAN FORCED

The circular element and fan come on. The heat is dispersed by forced convection and the temperature can be varied to between 50 °C and 250 °C via the thermostat knob. The oven does not require preheating.

Ideal for:

Food which has to be well-cooked outside and soft or rosy inside, for example lasagne, lamb, roast beef, whole fish etc.



FAN GRILL

Both the grill and the fan come on. Most of the cooking is done by grilling and then the hot air circulated around the oven. The oven door should be kept **closed**.

The temperature can be set between 50 °C and 200 °C max.

The oven should be preheated for 5 minutes before cooking. For further cooking hints see "GRILLING AND COOKING AU GRATIN".

Ideal for:

Quick sealing in of food juices for example such as hamburger, chicken pieces, chops.

It is recommended that you do not grill for longer than 30 minutes at any one time.

Attention: the oven door becomes very hot during operation.

Keep children away.



MAINTAINING TEMPERATURE AFTER COOKING OR SLOWLY HEATING FOODS

The upper element, the circular element and the fan come on. The heat is circulated by forced convection with greater intensity in the upper part. The temperature can be set to between 50 °C and 140 °C via the thermostat knob.

Ideal for:

Keeping food warm after any type of cooking. Slow heating of cooked food.



MULTI-FUNCTION

The upper and lower heating elements come on and the fan comes on - the heat from the element being circulated by the fan. The temperature range can be set to between 50 °C and 250 °C using the thermostat.

Ideal for:

Large bulky quantities of food that require even cooking throughout for example large roasts, turkey, roast turkey, cakes etc.

COOKING ADVICE

Remember to keep children away from the appliance when you use the grill or oven, since these parts become very hot.

STERILIZATION

Sterilization of foods to be preserved, in full and hermetically sealed jars, is done in the following way:

- Set the switch to position .
- Set the thermostat knob to position 185 °C and preheat the oven.
- Fill the dripping pan with hot water.
- Set the jars onto the dripping pan making sure they do not touch each other and the door and set the thermostat knob to position 135 °C.

When sterilization has begun, that is, when the contents of the jars start to bubble, turn off the oven and let cool.

Check your recycle book for full instructions.

WARMING BREAD

Set the switch to position  and the thermostat knob to position 150 °C. Bread becomes fragrant again if wet with a few drops of water and put into the oven for about 10 minutes at the highest temperature.

SIMULTANEOUS COOKING OF DIFFERENT FOODS

The oven set on position  can cook several different foods together. Foods as diverse as fish and cakes can be cooked together without the cross transference of flavours. This is because the fats and cooking smell that would normally be deposited on the different foods are oxidised and are not absorbed by the foods. The cooking temperature of the foods, however must be within 20 - 25 °C of each other. The food with the longest cooking time will be put into the oven first and the other foods are added as necessary according to their cooking times.

ROASTING

To obtain classical roasting, it is necessary to remember:

- that it is advisable to maintain a temperature between 180 °C and 200 °C.
- that the cooking time depends on the quantity and the type of foods.

GRILLING AND COOKING AU GRATIN

As the hot air completely covers the food to be cooked, grilling may be done with the food on the rack in the oven. The knob should be switched to position . The thermostat should be set to 50 °C and 200 °C max and the oven pre-heated. The food should be placed on a rack in the oven for the required cooking time. Adding a few dabs of butter before the end of the cooking time gives the golden "au gratin" effect.

It is recommended that you do not grill for longer than 30 minutes at any one time.

USE OF THE GRILL

Preheat the oven for about 5 minutes with the door closed.

Introduce the food to be cooked, positioning the rack as close to the grill as possible. The dripping pan should be placed under the rack to catch the cooking juices and fats.

Do not grill for longer than 30 minutes at any one time.

WARNING: Accessible parts may become hot when the grill is used. Children should be kept away.

RIGHT CONVENTIONAL OVEN

GENERAL FEATURES

This is a conventional oven with 4 cooking positions, thermostatically controlled, obtained by 3 heating elements (top, bottom and grill).

This oven is equipped with a special dish rack for use with the special function “”. In this setting you can use your conventional oven to warm the plates (at about 60 °C) before serving dinner.

For correct use of this function see the chapters “PLATE WARMING OR TRADITIONAL BAKE” and “USE OF SPECIAL DISH RACK”.

OPERATING PRINCIPLES

Heating and cooking in the **CONVENTIONAL** oven are obtained in the following ways:

a. by normal convection

The heat is produced by the upper and lower heating elements.

b. by radiat heat

The food is grilled by the infra red grill element.

WARNING:

The door is hot, use the handle.

During use the appliance becomes hot. Care should be taken to avoid touching heating elements inside the oven.

Figure 28

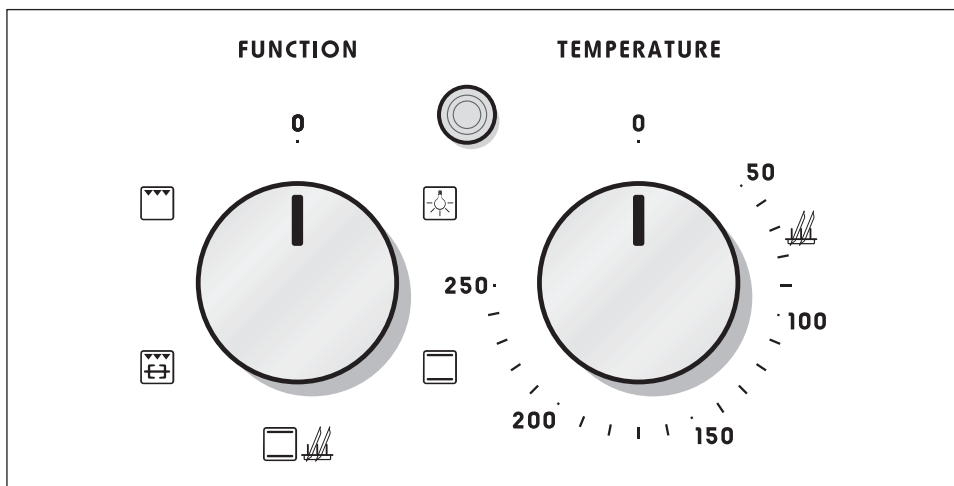

THERMOSTAT KNOB

This only sets the cooking temperature and does not switch the oven on. Rotate clockwise until the required temperature is reached (from 50 °C to 250 °C).

FUNCTION SELECTOR KNOB

Rotate the knob clockwise to set the oven for one of the following functions.



OVEN LIGHT

By setting the knob to this position, only the oven light comes on. It remains on in all the cooking modes.



TRADITIONAL BAKE

The upper and lower heating elements come on. The heat being dispersed by natural convection. The temperature range must be set between 50 °C and 250 °C using the thermostat. The oven must be preheated before cooking.

Ideal for:

Food that requires the same degree of cooking both inside and out, for example roasts, spare pork ribs, meringues etc.



PLATE WARMING OR TRADITIONAL BAKE

The upper and lower heating elements come on. The heat being dispersed by natural convection.

The temperature knob must be set to position  "Plate warming" to obtain the plates heating at about 60 °C.

This function can also be used for traditional bake. In this case the thermostat knob must be regulated between 50 °C and 250 °C.

Ideal for:

Dish warming using the special rack. For correct use see the chapter "USE OF SPECIAL DISH RACK".

KEEP ATTENTION: Plates are hot after warming. It is advisable to handle the plates using oven gloves.



GRILLING

The infrared grill element at the top of the oven comes on. The heat is dispersed by radiation.

Use with the **oven door closed** and the thermostat knob to position **225 °C** for max 15 minutes, then to position **175 °C**.

In the  position the rotisserie motor come on for cooking with the rotisserie.

For cooking hints, see the chapter "USE OF THE GRILL" "ROTISSERIE" and "USE OF THE ROTISSERIE".

Ideal for:

Intense grilling, browning, cooking au gratin and toasting etc.

It is recommended that you do not grill for longer than 30 minutes at any one time. Attention: the oven door becomes very hot during operation. Keep children away.

COOKING ADVICE

OVEN COOKING

Before introducing the food, preheat the oven to the desired temperature.

For a correct preheating operation, it is advisable to remove the tray from the oven and introduce it together with the food, when the oven has reached the desired temperature.

Check the cooking time and turn off the oven 5 minutes before the theoretical time to recuperate the stored heat.

USE OF THE GRILL

Switch the grill on, setting the two knobs:

- Function selector to  or  position.
- Thermostat selector to position **225 °C** for 15 minutes then to **175 °C**.

Leave to warm up for approximately 5 minutes with the **door closed**.

Place the food inside positioning the rack as near as possible to the grill.

Insert the drip pan under the rack to collect the cooking juices.

Grilling with the oven door closed and do not for longer than 30 minutes at any one time.

Attention: the oven door becomes very hot during operation. Keep children away.

ROASTING

To obtain classical roasting, it is necessary to remember:

- that it is advisable to maintain a temperature between 180 °C and 200 °C.
- that the cooking time depends on the quantity and the type of foods.

ROTISSERIE

This is used for spit roasting under the grill and comprises:

- an electric motor fitted to the rear of the oven
- a stainless steel skewer provided with slide-out heatless handgrip and two sets of adjustable forks
- a skewer support to be fitted in the middle runner.

The rotisserie motor is operated by the oven selector to  position.

USE OF THE ROTISSERIE (Fig. 29)

- Insert the tray into the lowest rack holders of the oven and insert the rod support into the intermediate rack holders.
- Put the meat to be cooked onto the rod, being careful to secure it in the center with the special forks.
- Insert the rod into the motor opening and rest it onto the support of the spit collar; then remove the grip by turning it to the left.

The rotation direction of the rotisserie can be either clockwise or counter-clockwise.

Figure 29

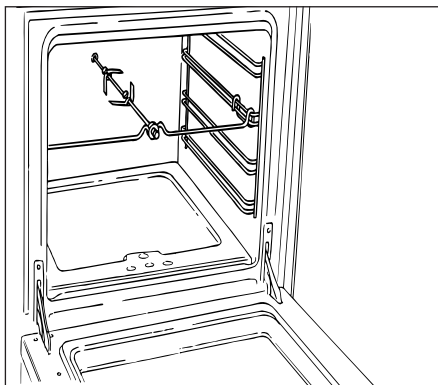

USE OF SPECIAL DISH RACK

This special shelf can be used as dish rack or turning over, as normal shelf for oven cooking.

It must be inserted between the guides of the lateral racks.

USING THE SPECIAL SHELF AS A DISH RACK

Slide in the shelf on the guides, on the lower level of the lateral racks.

The prongs where the plates are to be inserted, must be turned upwards.

The shelf must be fitted so that the safety catch, which stops it sliding out, faces the bottom of the oven (see detail of figure 30).

The plates must be positioned as indicated in figure 30.

To facilitate this operation, pull the special rack up to the safety lock.

KEEP ATTENTION: Plates are hot after warming. It is advisable to handle the plates using oven gloves.

USING THE SPECIAL RACK FOR NORMAL COOKING

Slide in the shelf on the guides: the safety catch must be turned toward the oven base (see detail of figure 31).

The flat surface can be used to put cooking pans or food directly on the rack - the dripping pan should be placed under the rack to catch the cooking juices and fats.

Figure 30

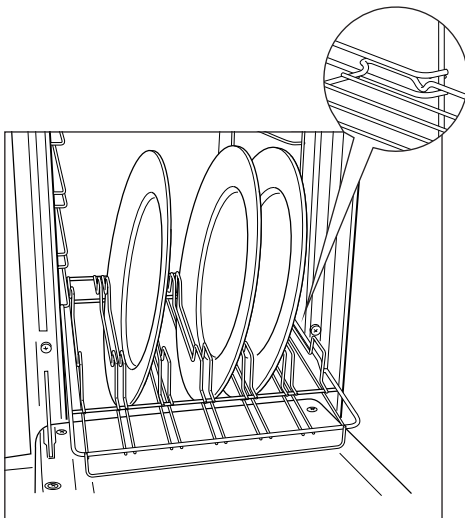
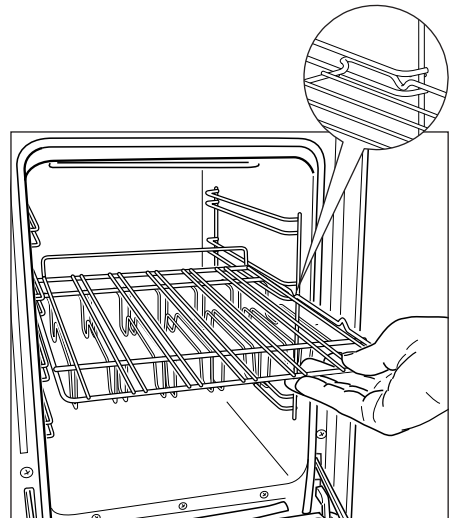

Figure 31



RECOMMENDED COOKING TEMPERATURE

Food	°C	°F	Gas Mark	Shelf Position*	Cooking Time (approx)
CAKES					
Victoria sandwich	190	375	5	2 or 3	20-25 mins
Small cakes/buns	190	375	5	1 and 2	15-20 mins
Maidera cake	180	350	4	2 or 3	20 mins
Fruit cake	170	325	3	3	1¾ hours
Rich fruit cake	150	300	2	3 or 4	2½ hours
Scones	225	425	8-9	2	8-10 mins
PASTRY					
Puff	225	425	8-9	2	10-20 mins
Short crust	200	400	6	2	20-30 mins
Plate tarts	200-210	400-410	6	1 or 2	30-35 mins
Quiches and flans	200-210	400-410	6	1 or 2	40-45 mins
YEAST					
Bread loaf	225	425	7-8	2	35-55 mins
Bread rolls	220	425	7	1 or 2	15-20 mins
Pizza dough	230	450	8	2	20 mins
ROAST MEAT					
Beef – Medium	190	375	5	2 or 3	20 mins/lb + 20 mins
Lamb	190	375	5	2 or 3	25-30 mins/b + 25 mins
Pork	190-200	375-400	5-7	2 or 3	30 mins/lb + 30 mins
Veal	190	375	5	2 or 3	30 mins/b + 30 mins
Chicken	190	375	5	2 or 3	30 mins/b + 30 mins
Turkey up to 10lb	180	350	4	2 or 3	18-20 mins/b + 20 mins
Stews/casseroles	150-170	300-325	2-3	2 or 3	1½-2 hours

N.B. For fan ovens reduce the temperature by 10-20 °C. For any dish taking one hour or over to cook, reduce the cooking time by 10 minutes per hour.







* Shelf positions have been counted from the top of the oven to the base. A fan oven creates more even temperature throughout, therefore the shelf positions are not as critical.

ELECTRONIC PROGRAMMER (Main left oven only)

The electronic programmer is a device which groups together the following functions:

- 24 hours clock with illuminated display
- Timer (up to 23 hours and 59 minutes)
- Program for automatic oven cooking (main oven only)
- Program for semi-automatic oven cooking (main oven only)



Description of the buttons:

-  Timer
-  Cooking time
-  End of cooking time
-  Manual position and cancellation of the inserted cooking programme
-  Advancement of the numbers of all programs
-  Turning back of the numbers of all programs and changing the frequency of the audible signal.

 Automatic cooking taking place

 Timer in operation

 and **AUTO** - flashing - Programme error.
(The time of day lies between the calculated cooking start and end time).

Note: Select a function by the respective button and, in 5 seconds, set the required time with the  /  buttons ("one-hand" operation). A power cut zeroes the clock and cancels the set programmes.

Description of the lighted symbols:

AUTO - *flashing* - Programmer in automatic position but not programmed

AUTO - *always lighted* - Programmer in automatic position with programme inserted.

Figure 32

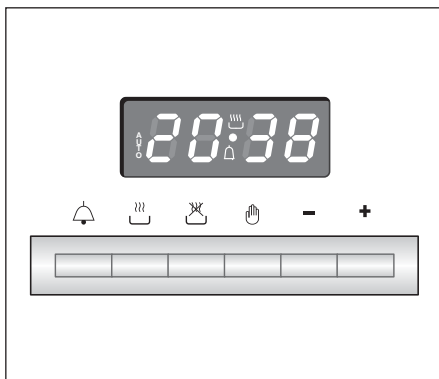
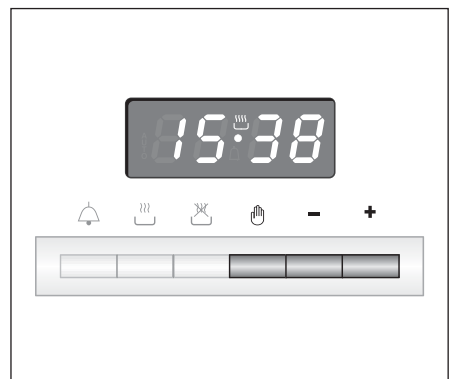





Figure 33







ELECTRONIC CLOCK (fig. 33)

The programmer is equipped with an electronic clock with lighted numbers which indicate hours and minutes.



Upon immediate connection of the oven or after a blackout, three zeroes will flash on the programmer panel.

To set the hour it is necessary to push the  button and then the  or  button until you have set the exact hour (fig. 33).

Alternatively, simultaneously push the   two buttons and at the same time push the  or  button.

Note: Setting the clock deletes any programme.

NORMAL COOKING WITHOUT THE USE OF THE PROGRAMMER

To manually use the oven, that is, without the aid of the programmer, it is necessary to cancel the flashing **AUTO** by pushing the button  (AUTO will be switched off and the symbol  will go on - Fig. 34).



Attention: If the AUTO is not flashing (which means a cooking programme has already been inserted), by pushing the button  you have cancelled the programme and switched to manual.



Figure 34



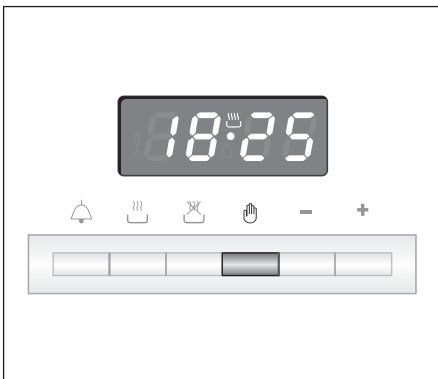

ELECTRONIC TIMER

The timer programme consists only of a buzzer which may be set for a maximum period of 23 hours and 59 minutes.

If the **AUTO** is flashing push the  button.

To set the time, push the  button and the  or  until you obtain the desired time (fig. 35).

Having finished the setting, the normal time will appear on the panel and the  symbol will appear.

The countdown will start immediately and may be seen at any moment on the panel by simply pressing the button .

At the end of the time, the  symbol will be switched off and an intermittent buzzer will go off; this can be stopped by pressing any one of the buttons.

ALTERING THE AUDIBLE SIGNAL

By pressing the  button you can choose from three variations.

Figure 35











AUTOMATIC OVEN COOKING

To cook food automatically in the oven, it is necessary to:

1. Set the length of the cooking time
2. Set the end of the cooking time
3. Set the temperature and the oven cooking programme.

These operations are done in the following way:

1. Set the length of the cooking time by pushing the  button and the  button to  advance, or to go back if you have passed the desired time (fig. 36). The **AUTO** and the  symbol will be on.
2. Set the end of the cooking time by pressing the  button (the cooking time already added to the clock time will appear), and the  button (fig. 37); if you pass the desired time you may get back by pushing the  button.

After this setting, the  symbol will go off. If after this setting, the **AUTO** flashes on the panel and a buzzer goes off, it means there was an error in the programming.

In this case, modify the end of cooking time or the cooking time itself by following the above instructions again.

Figure 36

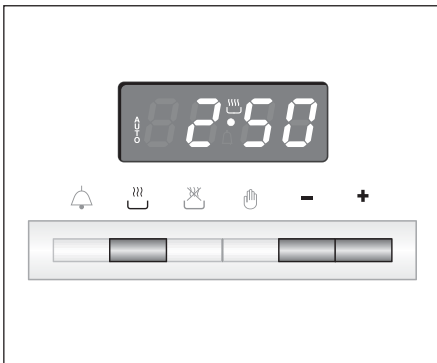



3. Set the temperature and the cooking programme by using the switch and thermostat knobs of the oven (see specific chapters).

Now the oven is programmed and everything will work automatically, that is the oven will turn on at the right moment to end the cooking at the established time.

During cooking, the  symbol remains on.

By pushing the  button you can see the time that remains until the end of cooking.

The cooking programme may be cancelled in any moment by pushing .

At the end of the cooking time the oven will turn off automatically, the  symbol will turn off, **AUTO** will flash and a buzzer will sound, which can be turned off by pushing any of the buttons.

Turn the switch and thermostat knobs to zero and put the programmer onto "manual" by pressing the  button.

Attention: A power cut makes the clock go to zero and cancels the set programmes.

After a power cut three zeroes will flash on the panel.

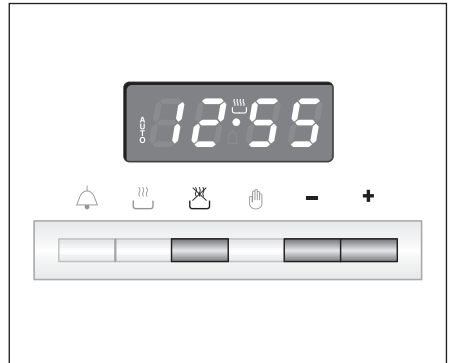

Figure 37





SEMI-AUTOMATIC COOKING

This is used to automatically switch off the oven after the desired cooking time has elapsed.

There are two ways to set your oven:



1. Set the length of the cooking time by pushing the  button and the  button to advance, or  to go backwards if you have passed the desired time (Fig. 38).

or

2. Set the end of the cooking time by pushing the  button and the  button to advance, or  to go backwards if you have passed the desired time (Fig. 39).

AUTO and the  symbol will be on. Then set the temperature and the cooking programme using the oven switch and thermostat knobs (see specific chapters).

The oven is switched on and it will be switched off automatically at the end of the desired time.

During cooking, the  symbol remains on and by pressing the button  you can see the time that remains till the end of the cooking.

The cooking programme can be cancelled at any moment by pushing the  button.

At the end of cooking, the oven and the  symbol will turn off, the **AUTO** will flash and a buzzer will sound; that can be stopped by pushing any of the buttons.

Turn the switch and thermostat knobs to zero and put the programmer onto "manual" by pressing the  button.

Figure 38



Figure 39

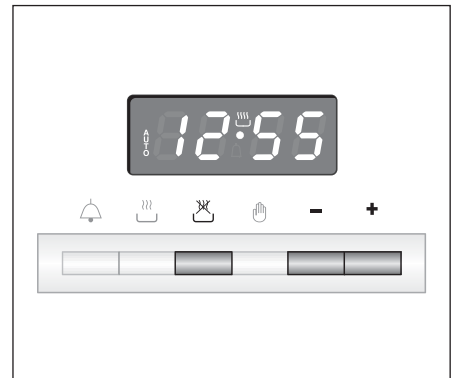

Cleaning and Maintenance

Maintenance Period	Description
Daily	<ul style="list-style-type: none">• Clean gas cooktop as per instructions below
Monthly	<ul style="list-style-type: none">• Remove burner caps, burner rings & base and clean using non abrasive detergent & rinse in cold water & dry thoroughly before replacing back on hob• Clean ignitor tip & thermocouple using damp soapy cloth and dry thoroughly
3 - 4 Yearly	<ul style="list-style-type: none">• Contact your local authorized gas Service Agent to perform a thorough check on all gas components on the gas cooker

GENERAL ADVICE

- **Before you begin cleaning, you must ensure that the appliance is switched off.**
- It is advisable to clean when the appliance is cold and especially when cleaning the enamelled parts.
- Avoid leaving alkaline or acidic substances (lemon juice, vinegar, etc.) on the surfaces.
- Avoid using cleaning products with a chlorine or acidic base.
- **Do not use a steam cleaner because the moisture can get into the appliance thus make it unsafe.**

WARNING

When correctly installed, your product meets all safety requirements laid down for this type of product category. However special care should be taken around the rear or the underneath of the appliance as these areas are not designed or intended to be touched and may contain sharp or rough edges, that may cause injury.

ENAMELLED PARTS

All the enamelled parts must be cleaned with a sponge and soapy water only or other non-abrasive products.

Dry preferably with a microfibre or soft cloth.

STAINLESS STEEL SURFACES

The stainless steel front panels on this cooker (facia, oven doors, storage compartment) are protected by a finger-print proof lacquer. To avoid damaging this lacquer, do not clean the stainless steel with abrasive cleaners or abrasive cloths or scouring pads.

ONLY SOAP/WARM WATER MUST BE USED TO CLEAN THE STAINLESS STEEL SURFACES.

INSIDE OF OVEN

- The oven should always be cleaned after use when it has cooled down. The cavity should be cleaned using a mild detergent solution and warm water. Suitable proprietary chemical cleaners may be used after first consulting with the manufacturers recommendations and testing a small sample of the oven cavity. Abrasive cleaning agents or scouring pads/cloths should not be used on the cavity surface.
- **NOTE:** The manufacturers of this appliance will accept no responsibility for damage caused by chemical or abrasive cleaning.
- **Do not store flammable material in the oven.**

ADVICE FOR USE AND MAINTENANCE OF CATALYTIC PANELS (left main oven only)

The catalytic panels are covered with special microporous enamel which absorbs and does away with oil and fat splashes during normal baking over 200°C.

If, after cooking very fatty foods, the panels remain dirty, operate the oven "idling" on max temperature for about 30 minutes. These panels do not require to be cleaned, however it is advised to periodically remove them from the oven (at least the side panels) and to wash them with tepid soapy water and then wipe off with a soft cloth.

DO NOT CLEAN OR WASH THEM WITH ABRASIVE PRODUCTS OR WITH PRODUCTS CONTAINING ACIDS OR ALKALIS.

The side panels are reversible and when the catalytic microporous enamel degrades, they can be turned to the other side.

GAS TAPS

If the gas taps are not working properly, call our Customer Service Centre to obtain the nearest Authorized Delonghi Service Agent.

GRILL HEATING ELEMENT

The heating element is self-cleaning and does not require maintenance.

REPLACING THE OVEN LIGHT BULB

Switch the cooker off at the mains.

When the oven is cool, unscrew and replace the bulb with another one resistant to high temperatures (300°C), voltage 230-240 V~ (50 Hz), E14 and same power (check watt power as stamped in the bulb itself) of the replaced bulb.

Note: Oven bulb replacement is not covered by your guarantee.

BURNERS

They can be removed and washed only with soapy water. Detergents can be used but must not be abrasive or corrosive.

Do not use abrasive sponges or pads.

Do not put in dishwasher.

After each cleaning, make sure that the burner-caps, as well as the burners, have been well wiped off and **CORRECTLY POSITIONED**.

It is essential to check that the burner flame distributor **F** and the cap **C** has been correctly positioned (see fig. 40) - failure to do so can cause serious problems.

Check that the electrode **S** (fig. 40) is always clean to ensure trouble-free sparking.

Check that the probe **T** (fig. 40) next to each burner is always clean to ensure correct operation of the safety valves. Both the probe and ignition plug must be very carefully cleaned.

Note:

The electrode S must be very carefully cleaned. To avoid damage to the electric ignition do not use it when the burners are not in place.

Figure 40

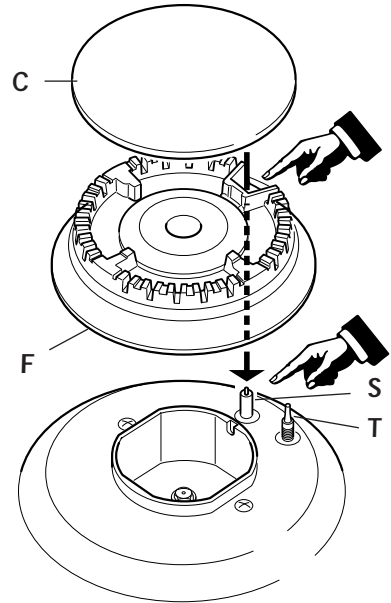

TRIPLE RING BURNER

The triple ring burner must be correctly positioned (see fig. 41); the burner rib must be located in position as shown by the arrow.

The burner correctly positioned must not rotate (fig. 42).

Then position the cap **A** and the ring **B** (fig. 42).

Figure 41

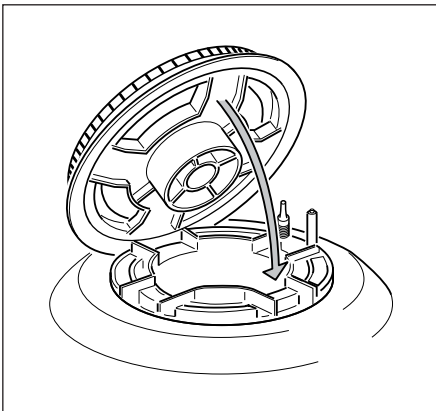
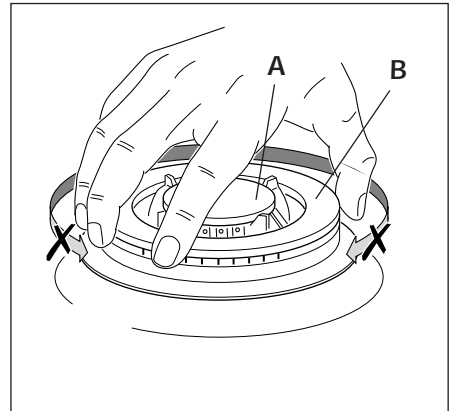

Figure 42



CORRECT POSITION OF THE FISH BURNER

This burner must be correctly positioned as shown in the figure 43.

Both the probe and ignition plug must be very carefully cleaned.

Figure 43

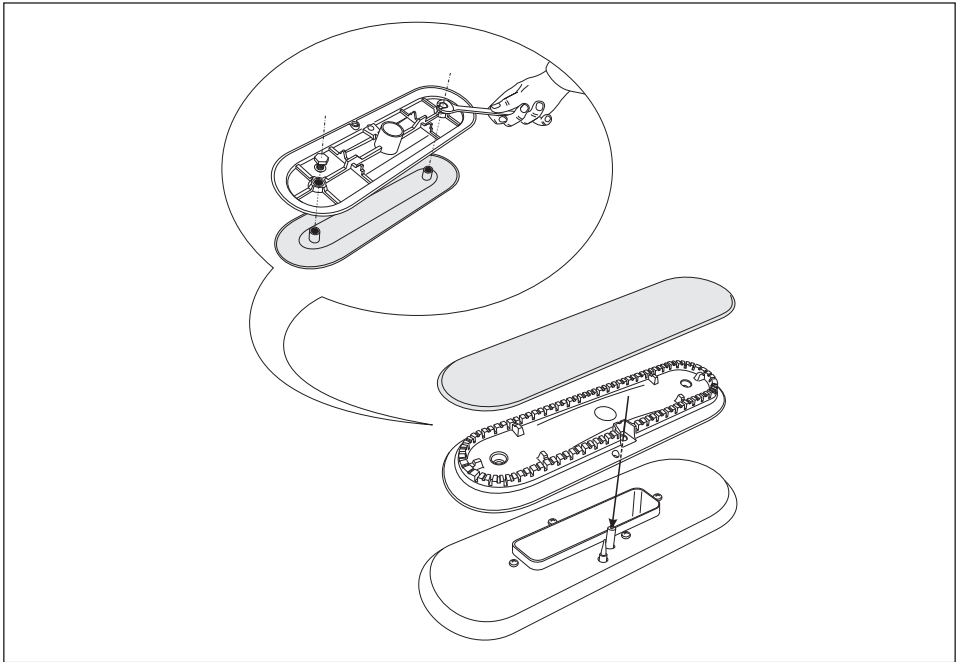

REMOVAL OF THE INNER GLASS DOOR PANEL

- The inner glass door panel can easily be removed for cleaning by unscrewing the two screws (fig. 44).
- When re-assembly ensure that the inner glass is correctly positioned and do not over tighten the screws.

Do not use harsh abrasive cleaners or sharp metal scrapers to clean the oven door glass since they can scratch the surface, which may result in shattering of the glass.

Figure 44

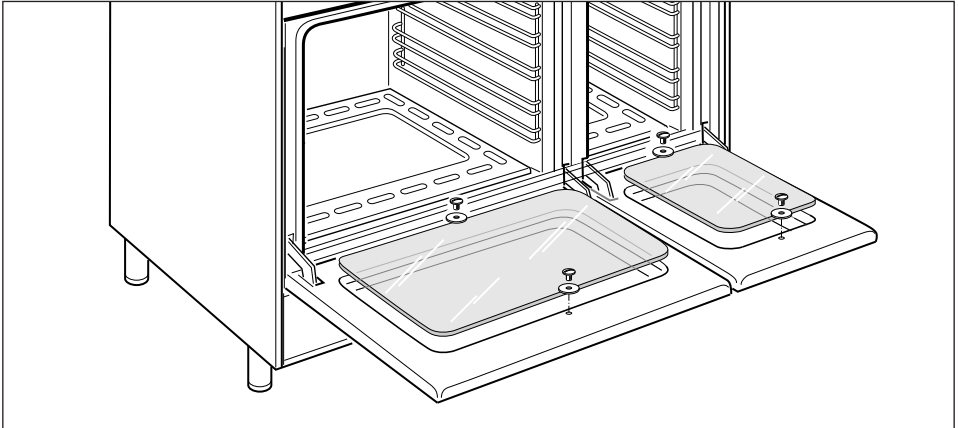

STORAGE COMPARTMENT

- The storage compartment is accessible through the pivoting panel.

Attention: Do not store flammable material in the ovens, or the storage compartment.

Figure 45

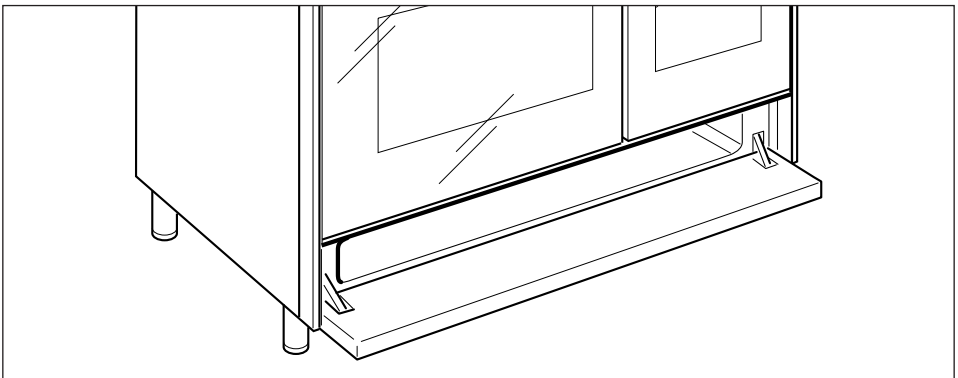

DISMANTLING THE DOOR

Please operate as follows:

- Open the door completely.
- The swivel retainers of the rh and lh hinges (fig. 46a) are hooked onto the metal bar above them (fig. 46b).
- Lift the oven door slightly. The notch on the bottom of the hinge will disengage (fig. 46c).
- Now pull the oven door forwards off the appliance. Release both hinge sections from the slots (fig. 46d).

DOOR ASSEMBLY

- Grip the door (as indicated in figure 46) and refit it in reverse order of removal procedure.

Figure 46

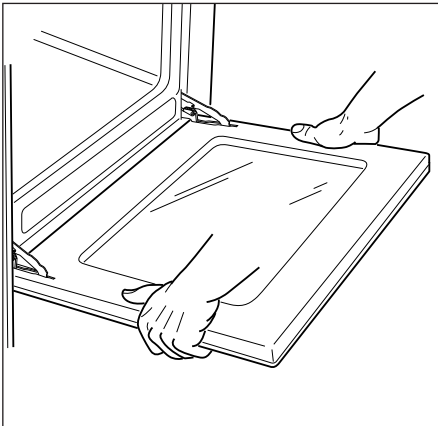

Figure 46a

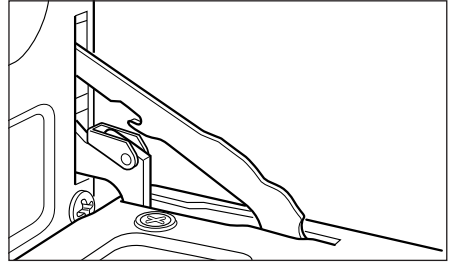

Figure 46b

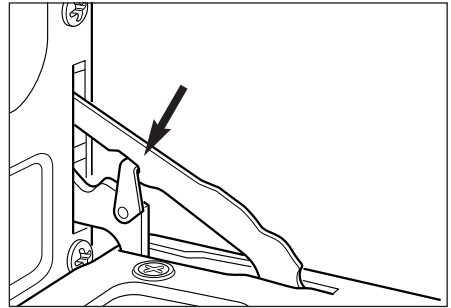

Figure 46c

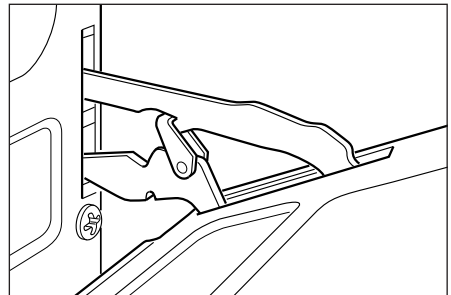
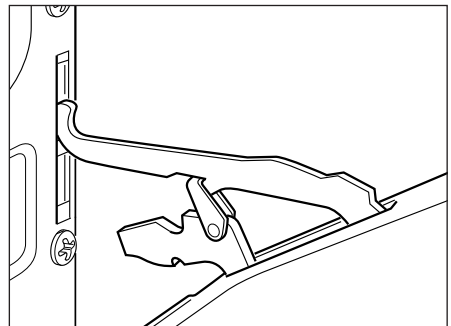

Figure 46d



Service and Maintenance

If the ignition spark fails to ignite or does not light the gas, check the following items before calling our Customer Service Centre to obtain the nearest Authorised Service Agent:

- Burner is reassembled and located correctly.
- Spark electrode and white ceramic are clean and dry.
- 240 VAC power supply is connected.

Contact the local gas utility or our Customer Service Centre to obtain the nearest Authorized Service Agent.

- You can smell gas when all burners are turned on.
- The burners do not remain alight at the minimum marked setting.
- The burner flame is yellow or emits an unusual odour.

Note that a bi-annual inspection of the appliance by an authorized service agent or your local gas utility will ensure many years of trouble free operation of your appliance.

WIRING DIAGRAM

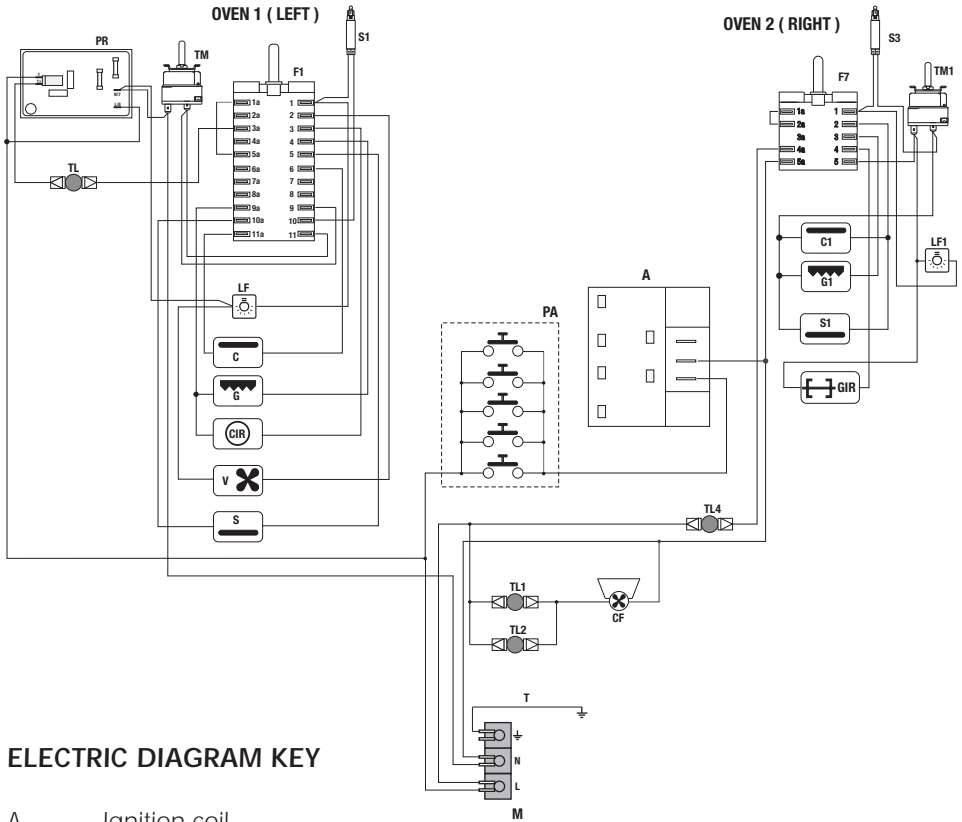

ELECTRIC DIAGRAM KEY

- A Ignition coil
- PA Ignition switches
- TL1/2 Cooling fan with thermolimitors
- CF Cooling fan
- M Terminal block
- T Hearth plant

LEFT OVEN

- F1 Oven switch
- TM Oven thermostat
- PR Programmer
- TL Thermal overload
- LF Oven Lamp
- S1 Thermostat pilot lamp
- C Top element
- G Grill element
- CIR Circular element
- V Fan
- S Bottom element

RIGHT OVEN

- F7 Oven switch
- TM1 Oven thermostat
- TL4 Thermal overload
- S3 Thermostat pilot lamp
- LF1 Oven Lamp
- C1 Top element
- G1 Grill element
- S1 Bottom element
- GIR Rotisserie

Descriptions and illustrations in this booklet are given as simply indicative. The manufacturer reserves the right, considering the characteristics of the models described here, at any time and without notice, to make eventual necessary modifications for their construction or for commercial needs.



Living innovation

cod. 1103191 B2