



5717010021 / 08.09



Consumer Helpline

Australia

Phone: 1800 126 659

Fax: 1800 007 289

New Zealand

Phone: 0508 200 300

Fax: 0508 200 301

www.delonghi.com.au

www.delonghi.co.nz

Distributed by De'Longhi Australia Pty Ltd.
ABN 49 104 012 857
P.O. Box 4156 Milperra BC, NSW 1891

Distributed by De'Longhi New Zealand Ltd.
P.O. Box 58-056 Greenmount, Auckland

 is a registered Trademark
of De'Longhi Australia Pty Ltd.
ABN 49 104 012 857.

© 2009 De'Longhi Australia Pty Ltd.

De'Longhi Beverage Cabinet

Model
DEBC 145



USER GUIDE

Please read this user guide carefully and retain for future reference

Features	03
De'Longhi Safety Precautions	04
Beverage Cabinet Safety Precautions	05
Installation Safety Precautions	07
Installation	08
- Warnings	
- Before using your Beverage Cabinet	
- Installation of your Beverage Cabinet	
- Reversing the door swing of your appliance	
- Installing Stainless Steel handle	
Using your Beverage Cabinet	10
- ON/OFF power	
- To lock the control panel	
- Setting the temperature control	
- Interior light	
- Door lock	
- Shelves	
Care and Cleaning	12
- Cleaning your Beverage Cabinet	
- Power failure	
- Moving your Beverage Cabinet	
- Energy saving tips	
Troubleshooting	13
Help us Help You	14
Warranty Information	15

The De'Longhi Beverage Cabinet is warranted against faults resulting from manufacturing or material defects. The warranty period for normal domestic installation and use is three years from the date of installation in your home. In non-domestic use De'Longhi limits the voluntary warranty to 6 months.

De'Longhi undertakes to repair or replace the Beverage Cabinet at our discretion if the product is found to be defective due to a manufacturing fault during the warranty period.

This warranty excludes any damage caused by misuse, neglect, shipping accident, or incorrect installation. Normal wear and tear is also expressly excluded. The warranty claim is void if no fault is found with the product or if work is carried out by anyone other than an authorised De'Longhi Service Agent.

In Australia, this warranty is additional to the conditions and guarantees which are mandatory as implied under the Trade Practices Act 1974 and State and Territory legislation.

How to contact us about a warranty claim

Talk to a De'Longhi representative for further warranty or product information please call the number in your country:

Australia

www.delonghi.com.au
Phone: 1800 126 659

New Zealand

www.delonghi.co.nz
Phone: 0508 200 300



NOTE: Warranty is determined by unit serial number and date of installation.

Read this guide carefully, it is intended to help you operate and maintain your new Beverage Cabinet properly.

Keep it handy to answer your questions. If you don't understand something or you need more assistance, please call the De'Longhi Helpline.

To help us provide prompt answers to your queries, please record your Beverage Cabinet model and serial numbers. You'll find them on a plate located on the rear outside wall of the Beverage Cabinet.

Beverage Cabinet details

Date of Purchase

Model Number

Serial Number

Before you call for service

Check the Troubleshooting Section on page 13. It lists causes of minor operating problems that you can correct yourself.

STAPLE OR
AFFIX PURCHASE
RECIPT HERE

Model: DEBC 145

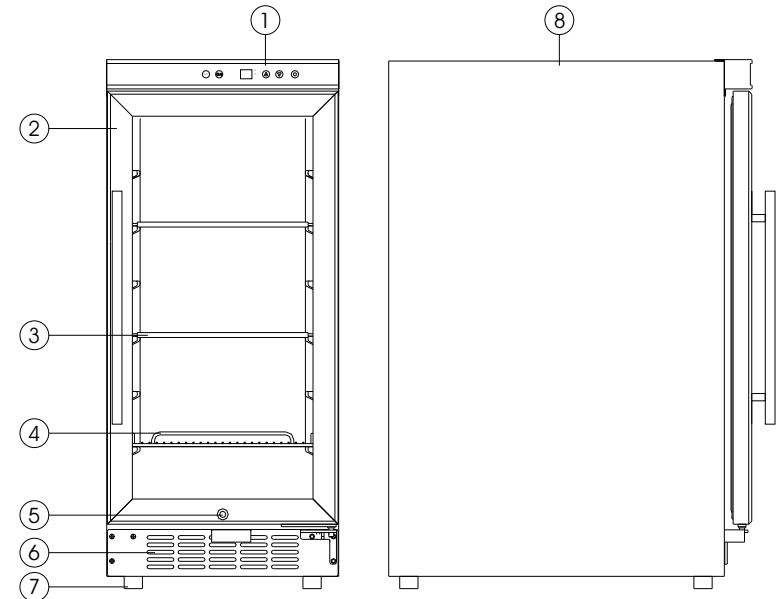

Components:

1. Digital control panel
2. UV tinted triple glaze door
3. Glass shelf (total 1)
4. Wire shelf (total 2)
5. Door Lock
6. Front Ventilation
7. Feet
8. Cabinet

Dimensions:

Height	855mm
Width	595mm
Depth	615mm

 **appliancesonline**
Australia's largest online appliance retailer

De'Longhi pride themselves on their innovative range of the highest quality consumer products.

De'Longhi ensures all of its products are 100% safe through quality design and manufacture. All products meet or exceed stringent laboratory-tested safety requirements.

It is necessary for anyone using an electrical appliance to be safety conscious. The following precautions are essential for the safe use of an electrical appliance. Carefully read all of the instructions provided with your appliance:

- Always turn the power off at the power outlet before you insert or remove a plug. Remove by grasping the plug, do not pull on the cord.
- Do not use your appliance with an extension cord unless this cord has been checked and tested by a qualified technician or service person. The extension cord must be a VDE-Listed, 3-wire grounding extension cord that has a grounding plug and outlet and that the electrical rating of the cord is 220-240 volts and at least 10 amperes.
- Always use your appliance from a power outlet of the voltage (A.C. only) marked on the appliance.
- Do not use an appliance for any purpose other than its intended use.
- Do not attempt to repair an electrical appliance. Return a damaged or malfunctioning appliance to a qualified service centre for adjustment or repair if required.
- The appliance must be positioned so the AC plug is accessible.

- This appliance is designed exclusively for household use. All other uses are strictly forbidden.
- The appliance is not intended for use by persons (including children) with reduced physical, sensory or mental capabilities, or lack of experience and knowledge, unless they have been given supervision or instruction concerning use of the appliance by a person responsible for their safety. Children should be supervised to ensure that they do not play with the appliance.
- If the power cable is damaged, it must be replaced by the manufacturer, an authorised service centre or a qualified electrician in order to eliminate all risk.
- **WARNING:** Do not damage the refrigerant circuit.

Beverage Cabinet does not operate

- Not plugged in.
- The appliance is turned off.
- The circuit breaker tripped or a blown fuse.

Beverage Cabinet is not cold enough

- Check the temperature control setting.
- External environment may require a higher setting.
- The door is opened too often.
- The door is not closed completely.
- The door gasket does not seal properly.

Turns on and off frequently

- The room temperature is hotter than normal.
- A large amount of contents has been added to the Beverage Cabinet.
- The door is opened too often.
- The door is not closed completely.
- The temperature control is not set correctly.
- The door gasket does not seal properly.

The light does not work

- Not plugged in.
- The circuit breaker tripped or a blown fuse.
- The light button is "OFF".

Vibrations

- Check to assure that the Beverage Cabinet is level.

The Beverage Cabinet seems to make too much noise.

- The rattling noise may come from the flow of the refrigerant, which is normal.
- As each cycle ends, you may hear gurgling sounds caused by the flow of refrigerant in your Beverage Cabinet.
- The Beverage Cabinet is not level.

The door will not close properly.

- The Beverage Cabinet is not level.
- The door was reversed and not properly installed.
- The gasket is dirty.
- The shelves are out of position.

Consumer Help

If you have any concerns or questions regarding the performance or use of your appliance, please visit  www.delonghi.com.au or **Australia's largest online appliance retailer** www.delonghi.co.nz

Australia

Phone: 1800 126 659
Fax: 1800 007 289

New Zealand

Phone: 0508 200 300
Fax: 0508 200 301

Cleaning your Beverage Cabinet

- Turn off the power, unplug the appliance, and remove all items including shelves.
- Wash the inside surfaces with a warm water and baking soda solution. The solution should be about 2 tablespoons of baking soda to a quart of water.
- Wash the shelves with a mild detergent solution.
- Wring excess water out of the sponge or cloth when cleaning area of the controls, or any electrical parts.
- Wash the outside cabinet with warm water and mild liquid detergent. Rinse well and wipe dry with a clean soft cloth.
- Do not use steel wool or steel brush on the stainless steel. These will contaminate the stainless steel with steel particles and rusting may occur.

Power Failure

Most power failures are corrected within a few hours and should not affect the temperature of your appliance if you minimize the number of times the door is opened.

If the power is going to be off for a longer period of time, you need to take the proper steps to protect your contents.

Moving your Beverage Cabinet

- Remove all items.
- Securely tape down all loose items (shelves) inside your appliance.
- Turn the adjustable leg up to the base to avoid damage.
- Tape the door shut.
- Be sure the appliance stays secure in the upright position during transportation. Also protect outside of appliance with a blanket, or similar item.

Energy Saving Tips

The Beverage Cabinet should be located in the coolest area of the room, away from heat producing appliances, and out of the direct sunlight.

**IMPORTANT SAFETY INSTRUCTIONS -
READ ALL INSTRUCTIONS BEFORE USING,
AND SAVE FOR FUTURE REFERENCE.**

Your safety and the safety of others is very important. Safety messages are displayed in this manual and on your appliance.

Read and obey these safety messages as they will alert you to potential hazards and tell you how to reduce the chance of injury.



Safety Alert Symbol

This symbol alerts you to potential hazards.



Danger

Danger indicates a high level of risk to yourself and others. Ensure that care is taken to avoid severe injury or even death.



Warning

Warning indicates a moderate level of risk to yourself, others and the product. Ensure that care is taken to avoid extensive product damage or serious injury.



Caution

Caution indicates a level of risk to yourself, others and the product. Ensure care is taken to avoid moderate product damage or injuries.



Before the appliance is used, it must be properly positioned and installed as described in this manual, so read the manual carefully. To reduce the risk of fire, electrical shock or injury when using the appliance, follow basic precaution, including the following:

⚠ DANGER ⚠

- Plug into a grounded 3-prong outlet, do not remove grounding prong, do not use an adapter, and do not use an extension cord.
- It is recommended that a separate circuit, serving only your appliance be provided. Use receptacles that cannot be turned off by a switch or pull chain.
- Never clean appliance parts with flammable fluids. These fumes can create a fire hazard or explosion. And do not store or use gasoline or other flammable vapours and liquids in the vicinity of this or any other appliance. The fumes can create a fire hazard or explosion.
- Do not connect or disconnect the electric plug when your hands are wet.
- Unplug the appliance or disconnect power before cleaning or servicing. Failure to do so can result in electrical shock or death.
- Do not attempt to repair or replace any part of your appliance unless it is specifically recommended in this material. All other servicing should be referred to a qualified technician.

⚠ WARNING ⚠

FOLLOW WARNINGS BELOW ONLY WHEN APPLICABLE TO YOUR MODEL

- Use two or more people to move and install appliance. Failure to do so can result in back or other injury.
- To ensure proper ventilation for your appliance, the front of the unit must be completely unobstructed. Choose a well-ventilated area with temperatures above 60°F (16°C) and below 90°F (32°C). This unit must be installed in an area protected from the element, such as wind, rain, water spray or drips.
- The appliance should not be located next to ovens, grills or other sources of high heat.
- The appliance must be installed with all electrical, water and drain connections in accordance with state and local codes. A standard electrical supply (240V AC only, 50 Hz), properly grounded in accordance with the local codes and regulations.
- Do not kink or pinch the power supply cord of appliance.
- The fuse (or circuit breaker) size should be 10 amperes.
- It is important for the appliance to be levelled in order to work properly. You may need to make several adjustments to level it.
- Never allow children to operate, play with or crawl inside the appliance.
- Do not use solvent-based cleaning agents or abrasives on the interior. These cleaners may damage or discolour the interior.
- Do not use this apparatus for other than its intended purpose.

Interior Light

- You can turn the interior light ON or OFF by touching the BULB button.

Door Lock

- Your unit is provided with a lock and key combination.

The keys are located inside the plastic bag that contains the User's Guide. Insert the key into the lock and turn it counterclockwise to unlock the door. To lock the door do the reverse operation making sure metal pin is engaged completely. Remove the key and place it in a secure place for safekeeping.

Shelves

The Beverage Cabinet is equipped with one glass shelf and two wire shelves. You can move the shelves out and in smoothly.

- To prevent damaging the door gasket, make sure to have the door all the way opened when pulling the shelves outward.
- For easy access to the storage content, you can pull the shelves outward to gain access to the items on the rear portion of the shelf, however this unit was designed with a plastic post on each sides of the shelf track to prevent the shelves from falling.
- When removing the shelf out of the inner rail, make sure to remove all items first. Then move the shelf to the position where the notch of shelf is exactly under the plastic post and lift the shelf. In order to replace the shelf, repeat steps described above in reverse.

1 x Glass Shelf

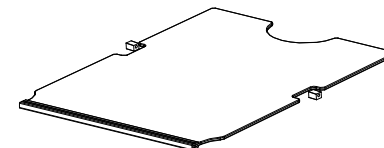

2 x Wire Shelves

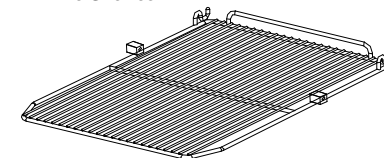

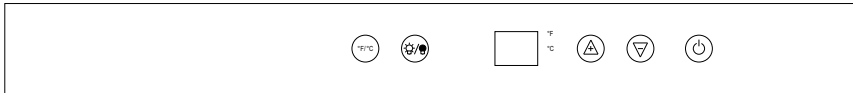

- The temperature range of this Beverage Cabinet is 2°C to 10°C.
- It is recommended you install the Beverage Cabinet in a place where the ambient temperature is between 23°C-26°C/ 72°-78°F. If the ambient temperature is above or below recommended temperatures, the performance of the unit may be affected. For example, placing your unit in extreme cold or hot conditions may cause interior temperatures to fluctuate and the range of 2°C to 10°C may not be reached.
- You can select temperature display setting from Fahrenheit to Celsius degree by touching the °F/°C mark. Fahrenheit or Celsius degrees indicator will appear in green color in the temperature display window.

ON/OFF Power

- To turn the appliance ON or OFF, press and hold the POWER button for 2 seconds.

To Lock the Control Panel

- Your Beverage Cabinet is equipped with an automatic Control panel lock function. This function will prevent any unwanted changes to your temperature or power settings.
- The lock function will activate automatically 12 seconds after the last time a button is pushed on the control panel.

- To unlock the control panel lock press and hold the UP and DOWN arrow buttons for 3 seconds the control panel will beep and blink once indicating that the control panel is active and the settings can be changed.

Setting the Temperature Control

- You can set the temperature as you desire by touching the UP or DOWN arrow buttons. When you touch the two buttons for the first time, the LED readout will show the original temperature set at previous time (the temperature preset at the factory is 2°C to 10°C).
- The temperature that you desire to set will increase 1°F or 1°C if you touch the UP button once, on the contrary the temperature will decrease 1°F or 1°C if you touch the DOWN button once.
- The temperature inside the unit will appear in blue in the display window.

NOTE:

- If the unit is unplugged, power lost, or turned off, you must wait 3 to 5 minutes before restarting the unit. If you attempt to restart before this time delay, the Beverage Cabinet will not start.
- When you use the Beverage Cabinet for the first time or restart the Beverage Cabinet after having been shut off for a long time, there could be a few degrees variance between the temperature you select and the one indicated on the LED readout. This is normal and it is due to the length of the activation time. Once the Beverage Cabinet is running for a few hours everything will be back to normal.

Electrical Connection

- This appliance should be properly grounded for your safety. The power cord of this appliance is equipped with a three-prong plug which mates with standard three prong wall outlets to minimise the possibility of electrical shock.
- Do not under any circumstances cut or remove the third ground prong from the power cord supplied. For personal safety, this appliance must be properly grounded.
- This appliance requires a standard 240 Volt AC ~/50Hz electrical ground outlet with three-prong. Have the wall outlet and circuit checked by a qualified electrician to make sure the outlet is properly grounded. When a standard 2-prong wall outlet is encountered, it is your responsibility and obligation to have it replaced with a properly grounded 3-prong wall outlet.
- The cord should be secured behind the appliance and not left exposed or dangling to prevent accidental injury.
- The appliance should always be plugged into its own individual electrical outlet which has a voltage rating that matches the rating label on the appliance. This provides the best performance and also prevent overloading house wiring circuits that could cause a fire hazard from overheated. Never unplug the appliance by pulling the power cord. Always grip the plug firmly and pull straight out from the receptacle. Repair or replace immediately all power cords that have become frayed or otherwise damaged. Do not use a cord that shows cracks or abrasion damage along its length or at either end. When moving the appliance, be careful not to damage the power cord.

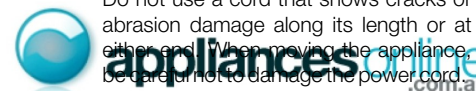

Australia's largest online appliance retailer

Extension Cord

- Because of potential safety hazards under certain conditions, it is strongly recommended that you do not use an extension cord with this appliance. However, if you must use an extension cord it must be checked and tested by a qualified technician or service person. The extension cord must be a VDE-Listed, 3-wire grounding extension cord that has a grounding plug and outlet and that the electrical rating of the cord is 220-240 Volts and at least 10 amperes.

⚠ WARNING ⚠

To reduce the risk of fire, electrical shock, or injury when using your appliance, follow these basic precautions:

- Read all instructions before using the Beverage Cabinet.
- **DANGER or WARNING:** Risk of child entrapment.
Child entrapment and suffocation are not problems of the past. Junked or abandoned appliances are still dangerous . . . even if they will “just sit in the garage a few days”.
- **Before you throw away your old Beverage Cabinet:** Take off the door. Leave the shelves in place so that children may not easily climb inside
- Never allow children to operate, play with, or crawl inside the appliance.
- Never clean appliance parts with flammable fluids. The fumes can create a fire hazard or explosion.
- Do not store or use gasoline or any other flammable vapors and liquids in the vicinity of this or any other appliance. The fumes can create a fire hazard or explosion.

Before using your Beverage Cabinet

- Remove the exterior and interior packing.
- Check to be sure you have all of the following parts:
 - 1 x Glass Shelf
 - 2 x Wire Shelves
 - 2 x Keys
 - 1 x Stainless Steel Handle Assembly with Hardware
 - 2 x Decorative Screws.
 - 1 x Instruction Manual.

- Before connecting the Beverage Cabinet to the power source, let it stand upright for approximately 2 hours. This will reduce the possibility of a malfunction in the cooling system from handling during transportation.
- Clean the interior surface with lukewarm water using a soft cloth.
- Install the handle on the left side of the door.

Installation of your Beverage Cabinet

- This appliance is designed to be for free standing installation or built-in (fully recessed).
- Place your Beverage Cabinet on a floor that is strong enough to support it when it is fully loaded. To level your Beverage Cabinet, adjust the front levelling legs at the bottom of the Beverage Cabinet.
- Locate the Beverage Cabinet away from direct sunlight and sources of heat (stove, heater, radiator, etc.). Direct sunlight may affect the acrylic coating and heat sources may increase electrical consumption. Extreme cold ambient temperatures may also cause the unit not to perform properly.
- Avoid locating the unit in moist areas.
- Plug the Beverage Cabinet into an exclusive, properly installed-grounded wall outlet. Do not under any circumstances cut or remove the third (ground) prong from the power cord. Any questions concerning power and/or grounding should be directed toward a certified electrician or an authorised service center.

Clearances

- Clearances required for the Beverage Cabinet to adjacent surfaces are 10mm from top and sides, and 50mm from rear.

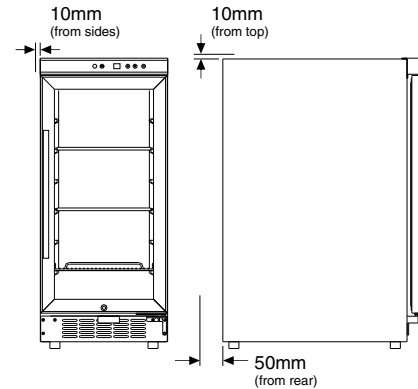

Reversing the Door Swing of Your Appliance

- This appliance has the capability of the door opening from either the left or right side. The unit is delivered to you with the door opening from the left side. Should you desire to reverse the opening direction, please call service for reversal instructions.

Installing stainless steel handle

This Beverage Cabinet includes a stainless steel handle that is not required to operate this unit.

To install the handle please follow the below instructions:

For your convenience the screws used in the installation of the handle have been put in place for you.



- Pull away the door gasket (A) in the area where the handle is to be installed on the left side as in Illustration #1. The gasket is easily displaced by hand, no tools are necessary.
- Align the handle (B) with the screws (C) installed. Tighten the screws (C) using a Phillips head screwdriver until the handle sets both flush and secured tightly against the door frame. (DO NOT over tighten as this will cause damage to the handle assembly).
- Replace the door gasket (A) to its original position.
- If you choose not to use the handle supplied, simply follow step 1 to access the installation screws and remove them and then place the two decorative plugs into the two holes separately. Continue on to step 3 to replace the door gasket to its original position.

