



INSTALLATION and SERVICE INSTRUCTIONS
USE and CARE INSTRUCTIONS

DEH60S
DEH60W

ELECTRIC COOKTOPS



distributed by
DèLonghi
Pty Ltd

INSTALLATION

CAUTION:

- In order to avoid a hazard this appliance must be installed according to these instructions for installation.

WARNING:

- This appliance is to be installed only by an authorised person.
- This appliance must be used only for the task it has explicitly been designed for, that is for cooking foodstuffs. Any other form of usage is to be considered as inappropriate and therefore dangerous.
- Do NOT place combustible materials or products on this appliance at any time.
- Do NOT spray aerosols in the vicinity of this appliance while it is in use.
- **IMPORTANT NOTE: This appliance shall not be used as a space heater, especially if installed in marine craft or caravans.**
- **The appliance is not intended for use by young children or infirm persons without supervision.**
- **Young children should be supervised to ensure they do not play with the appliance without supervision.**

TECHNICAL INFORMATION:

Rapid plate	Ø 145	1500 W
Rapid plate	Ø 180	2000 W
Normal plate	Ø 180	1500 W
Normal plate	Ø 145	1000 W
Voltage	230 - 240 VAC 50 Hz	
Maximum absorbed power	6.0 - 6.5 kW	

DIMENSIONS (Table 2):

(Note: Also refer to Figure 1 side)

General Dimensions	
Width	580 mm
Depth	500 mm
Depth Below Mounting Surface	30 mm
Cut-out Dimensions	
Width	550 mm
Depth	470 mm

This cooktop has been designed and constructed in accordance with the following codes and specifications:

AS/NZS 60335-1 General Requirements for Domestic electrical appliances

AS/NZS 60335-2-6 Particular Requirements for Domestic electrical cooking appliances

AS/NSZ 1044 Electromagnetic Compatibility Requirements.

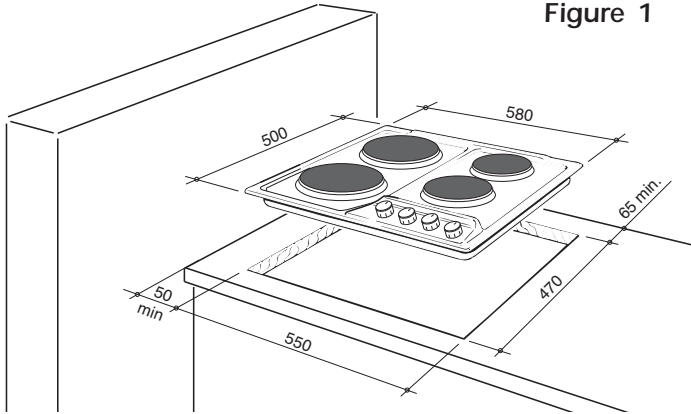

Figure 1

CLEARANCES:

Installation clearances and protection of combustible surfaces shall comply with page 4.

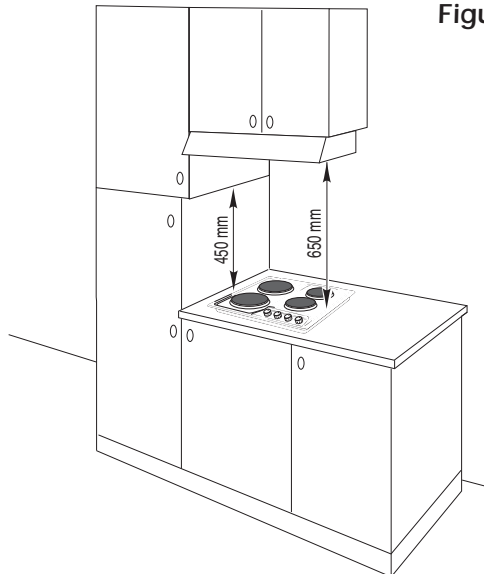

Figure 2

The installation shall comply with the dimensions in Figures 1 and 2, bearing in mind that:

- **A minimum clearance of 30 mm** has to be kept between the bottom of the cooking hob and the top of an appliance or a thermal barrier (see next page).
- **Overhead clearances** - In no case shall the clearance between the highest part of the hob and a range hood be less than 600 mm. Any other downward facing combustible surface less than 600 mm above the highest part of the hob shall be protected for the full width and depth of the cooking surface area. However, in no case shall this clearance to any surface be less than 450 mm.
- **Side clearances** - Where the dimension from the periphery of the nearest burner to any vertical combustible surface is less than 200 mm, the surface shall be protected to a height of not less than 150 mm above the hob for the full dimension (width or depth) of the cooking surface area.
- **Protection of combustible surfaces** - The required protection shall ensure that the surface temperature of the combustible surface does not exceed 50 °C above ambient. The fixing of 5 mm thick ceramic tiles to the surface or attaching fire resistant material to the surface and covering with sheet metal with minimum thickness of 0.4 mm would satisfy this requirement.

Caution:

The underside surface of the cooking hob can reach a temperature exceeding 95 °C during normal use.

If after installation the underside surface is accessible through under-bench cupboard doors and the like, it is essential that a rigid barrier is installed so that such access is restricted. In order to avoid a hazard the barrier must be of low thermal conductivity material installed according to the instructions for installation.

THERMAL BARRIER INSTALLATION:

Warning:

- If the hob is installed over drawers or cupboards, a thermal protection barrier must be fitted at least 30 mm beneath the base of the hob (see Figure 3).

Note:

1. Above not applicable if hob is mounted directly above an oven
2. For access to the hob for servicing or installation, ensure that the barrier can be removed from beneath by the use of a tool.
3. A gap of 20 mm may be allowed at rear for electrical connection and ventilation.

THERMAL PROTECTION BARRIER

(min. 15 mm thick)

Fitted the full lengths of the hob below the workbench and must be removable with the use of a tool for installation and service.

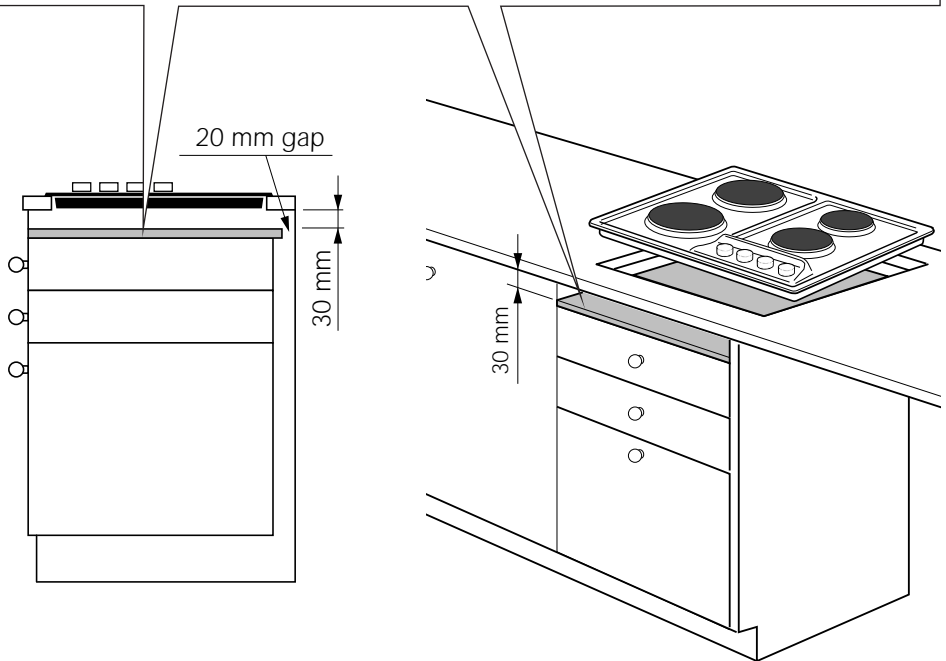
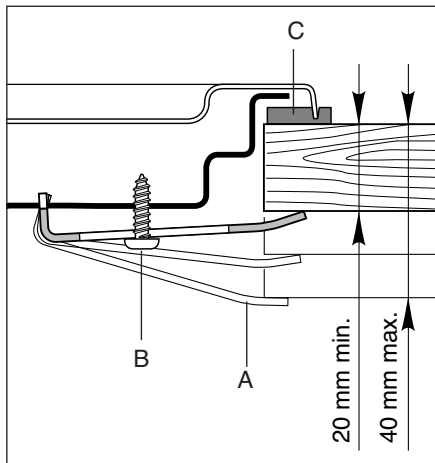

Figure 3

INSTALLATION

1. Spread out the gasket "C" over the workbench at the edge of the cut out taking care to overlap the gasket at the corners.
2. Slot in the cooking hob into the cut out of the workbench and locate it correctly.
3. Adjust the clamps "A" and tighten the screws "B" until the hob is firmly secured.
4. Using a sharp tool, trim any excess gasket which protrudes from the edge of the hob. **Take care not to damage the countertop.**

Figure 4



ELECTRICAL REQUIREMENTS

Warning:

- THIS APPLIANCE MUST BE EARTHED.
- In order to avoid a hazard this appliance must be installed according to these instructions for installation.

Caution:

- **If the supply cord is damaged it must be replaced by the manufacturer or its Service Agent or a similarly qualified person in order to avoid a hazard.**
 - Ensure that the power outlet is properly earthed before connecting the appliance.
 - Disconnect power before servicing the appliance.
 - The connection to the electrical network must be carried out by qualified personnel and must be according to standards in force.
 - The appliance must be connected to the electrical network verifying above all that the voltage corresponds to the value indicated on the specifications plate and that the cables section of the electrical plant can bear the load which is also indicated on the plate.
-
- It is possible to effect the direct connection to the network interposing a omnipolar switch between the appliance and the electrical network with a minimum opening of 3 mm between contacts.

FEEDER CABLE CONNECTION

To connect the feeder cable to the cooking hobs with electrical plates or to replace, if necessary, some electrical part, it is necessary to:

- Upturn the hob
- Unscrew screws "A" and remove protection "B" (fig. 5)
- Insert connecting plates "C" into terminal block "D" (fig. 7) as shown in the diagram in fig. 6
- Unscrew cable clamp "E" (fig. 5)
- Insert correct section and type mains flex (see special chapter) through mains hitch "F" of protection "B," and connect mains and earth wires to their respective terminals in block "D," in accordance with the diagram shown in fig. 8 (next page).
- Tighten mains flex, and fix it with clamp "E."
- Replace protection "B," keeping flex taut.

Figure 5

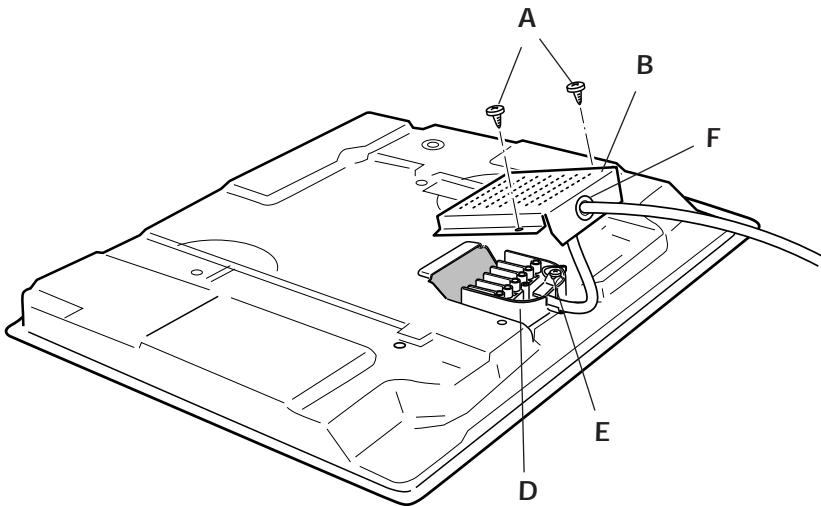
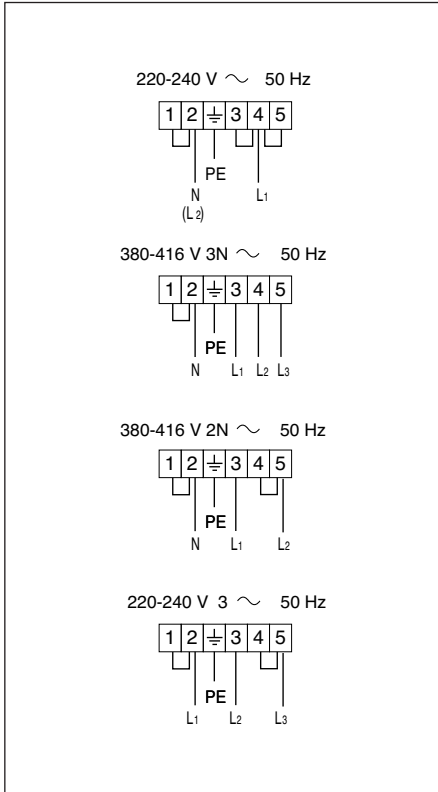

Figure 6



**FEEDER SPECIAL CABLE
SECTION Type "HO5V2V2-F"
resistance to temperatures of
90°C**

220-240 V ~ 50 Hz	3 x 2,50 mm ²
380-416 V 3N ~ 50 Hz	5 x 1,50 mm ²
380-416 V 2N ~ 50 Hz	4 x 1,50 mm ²
220-240 V 3 ~ 50 Hz	4 x 2,50 mm ²

Figure 7

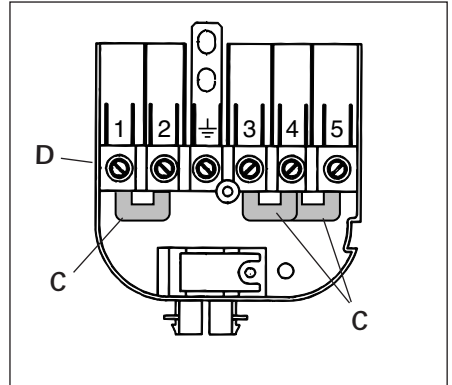

USE and CARE

CAUTION:

- This appliance must be used only for the task it has explicitly been designed for, that is for cooking foodstuffs. Any other form of usage is to be considered as inappropriate and therefore dangerous.
- Do NOT place combustible materials or products on this appliance at any time.
- Do NOT spray aerosols in the vicinity of this appliance while it is in use.
- **The appliance is not intended for use by young children or infirm persons without supervision.**
- **Young children should be supervised to ensure they do not play with the appliance without supervision.**

Figure 9

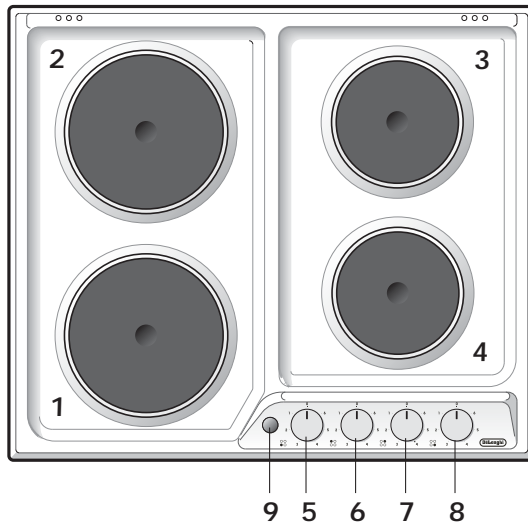

POSITION OF ELECTRIC PLATES

1. Front left electric plate Ø 180 - Rapid - 2000 W
2. Rear left electric plate Ø 180 - Normal - 1500 W
3. Rear right electric plate Ø 145 - Normal - 1000 W
4. Front right electric plate Ø 145 - Rapid - 1500 W

CONTROL PANEL

5. Front left electric plate 1 control knob
6. Rear left electric plate 2 control knob
7. Rear right electric plate 3 control knob
8. Front right electric plate 4 control knob
9. Electrical plates control lamp

■ **Important:** Before using the hob for the first time, it is necessary to burn off the appliance to dry off the plates and remove any protective coatings that may still be on the plates. To do this, boil a saucepan of water on each plate for about 10 minutes. There may be a strong odour and a light smoke visible during this process. This will cease when the process is complete.

1. Make sure that all the controls are turned to zero.
2. Switch on the electricity.
3. Turn the knob for the ring you require. The element will become hotter as you select a higher number. A little practice will help you to estimate the setting required for different purposes.
4. Always use a flat bottomed saucepan which has a base as similar to the diameter of the hotplate as possible. Ensure that the bottom of the pan you are using is dry.
5. Never switch the hotplate on without any saucepans on top. This will cause heat to travel along the spillage tray causing the control panel to heat up and may also cause subsequent damage to adjacent worktops.

Figure 10

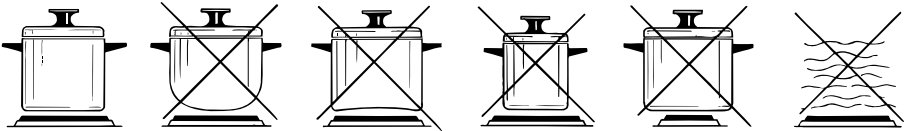

■ **Never cook food directly on the hotplate: always use a pan or suitable container.**

COOKING HINTS:

- Be careful not to place any wet or steamed up lids on an unused hotplate, as this will lead to rust.
- Pans should have a thick flat base to be effective. Check the base of the pan with a ruler. It should be either the same size or slightly larger than the hotplate.
- The plates with a red dot in the middle heat up 30% faster than those without.
- Do not use decorative covers over the hotplates as these hold condensation and could be dangerous if the hob was accidentally turned on.
- Using pans with tight fitting lids when cooking reduces cooking time and saves energy.
- Turn the heat off a short time before you finish cooking and the residual heat from the hotplate will finish the cooking for you.
- Never have handles overhanging the worktop - they can easily be caught and overbalance; similarly, never have the handles overlapping other hotplates that are in use.
- It is always worthwhile buying good saucepans for the best results from your hob.

Warning:

- **HOB'S BECOME VERY HOT WITH USE, AND RETAIN THEIR HEAT FOR A LONG TIME AFTER COOKING HAS FINISHED. CHILDREN SHOULD BE SUPERVISED AT ALL TIMES AND BE PREVENTED FROM TOUCHING THE HOT SURFACES UNTIL SUCH TIME AS THE APPLIANCE HAS COOLED.**

The table below shows recommended heat settings for cooking different types of food with your electric hob:

HEAT POSITION	DESCRIPTION	RECOMMENDED COOKING
1	Very Gentle	To keep food warm
2	Gentle	Stews, cream sauce
3	Slow	Frozen food, boiling water
4	Medium	Boiling potatoes, soup, vegetables, fish
5	High	Large stews, omelettes
6	Fast	Steaks, escalops, frying

- Please note that these are only guidelines, you will quickly learn from experience which setting is correct for your needs.

ECONOMIC COOKING

- The electric plate retains heat, so you may find that you can switch off the heat 5 minutes before you finish cooking.
- To reduce the cooking time, the plate can be set to the maximum setting at the beginning. It can then be reduced later.

CLEANING AND MAINTENANCE

- Before you begin cleaning you must ensure that the hob is switched off.
- **Do not use a steam cleaner because the moisture can get into the appliance thus make it unsafe.**
- Deposits of fat on the electric hotplates can be removed by turning on the hob for a few seconds. The fat will dry out, and can be brushed off when the plate is cool. If staining remains, special cleaners for electric plates can be purchased to return the plate to its original colour
- Electric hotplates are made of cast iron and though durable, will rust if moisture is left on them regularly. Do not place wet lids from other pans onto an unused hotplate. From time to time, apply a thin coat of special hob cleaner.

Enamelled parts - mod. DEH60W

- All the enamelled parts must be washed only with a sponge with soapy water or other non-abrasive products.
- Dry carefully.

Stainless steel hob - mod. DEH60S

- Clean with special products which are available on the market.
- Dry preferably with a microfibre or soft cloth.

TROUBLESHOOTING:

If you acquire a problem with your hob, check the following points before calling an engineer.

1. The power is switched on.
2. The controls are switched on.
3. Both the fuse and the mains fuse are intact.

Servicing the appliance:

Service may be obtained from your local **Authorised** Service Centre.



Living innovation

cod. 1103193 - B1