

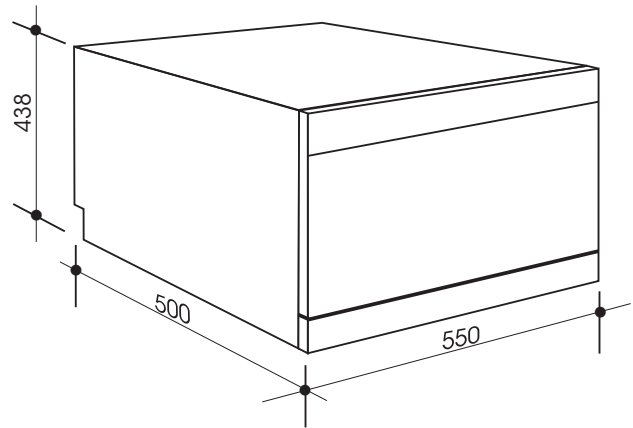

- heat element 230V
- micro + flat filters, plastic/stainless steel
- foldable plate racks
- low-spray arms
- detergent and rinse aid dispenser
- water softener dispenser
- cold/hot water inlet hoses
- inlet hose length: 2400mm
- outlet hose length: 1500mm
- packaged dimensions 605mmW x 555mmD x 518mmH

finish	white
installation	countertop, freestanding or built-in
size	438mmH x 550mmW x 500mmD
capacity	six place settings (IEC international)
programs	six
controls	electronic, LED display
drying	residual heat hot air
water security	adaptor hose supplied
filtration	two stage
basket	25cm diameter plates
warranty	two years parts and labour



PLEASE NOTE: drawings are not to scale. They are to assist only.