

Haier

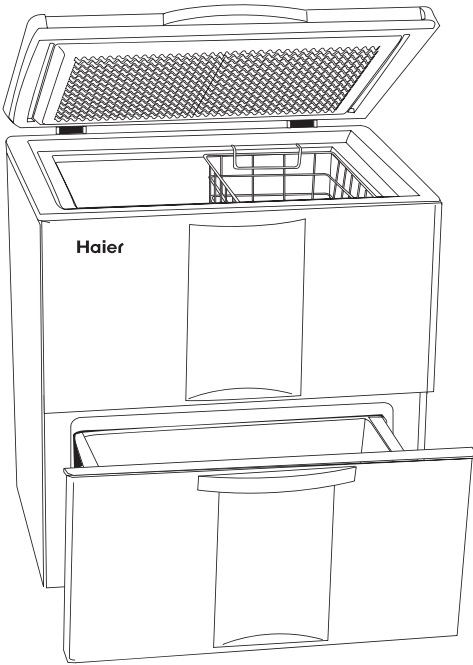

Bottom Drawer Chest Freezer

For domestic use only

User Manual

Model #'s

HFM185D

SAFETY PRECAUTIONS

Read all of the instructions before using this appliance and always exercise basic safety precautions, including the following:

- 1) Use this appliance only for its intended purpose as described in this use and care guide.
- 2) This freezer must be properly installed in accordance with the Installation instructions before it is used.
- 3) Never unplug your freezer by pulling on the power cord. Always grasp the plug firmly and pull straight out from the outlet.
- 4) Repair or replace immediately, all power cords that have become frayed or otherwise damaged. Do not use a cord that shows cracks or damage along its length, the plug or the connector end.
- 5) Unplug your freezer before cleaning or making any repairs.

Note: *If for any reason this product requires service, we recommend that a certified technician is called.*

- 6) Do not use any electrical device or any sharp instrument to defrost your freezer.
- 7) If your freezer is left unused for a time, we recommend that you remove the door and leave the shelves in place. This will reduce the possibility of danger to children.
- 8) When the freezer is in operation, do not touch the cold surfaces in the freezer compartment particularly when hands are damp or wet. Skin may adhere to these extremely cold surfaces.
- 9) It is not safe to refreeze foods, which have been thawed completely unless they still contain ice crystals
Thawed ground meats, poultry, or fish that have any off-odour or offcolor should not be refrozen and should not be eaten. Thawed ice cream should be discarded. If the odour or colour of any food is poor or questionable, discard it. The food may be dangerous to eat.
Even partial thawing and re-freezing reduces the eating quality of foods, particularly fruits, vegetables, and prepared foods. The eating quality of red meats is affected less than that of many other foods. Use refrozen foods as soon as possible, to save as much of its eating quality as you can.
- 10) This freezer should not be recessed or built-in an enclosed cabinet. It is designed for freestanding installation only.
- 11) Do not operate your freezer in the presence of explosive fumes.
- 12) Do not install the freezer near inflammable and explosive fumes.
- 13) After installation of the freezer, its plug should be accessible.
- 14) Do not expose the freezer to the rain.
- 15) If the freezer is moved, the electric cable of the freezer should be wound and secured to prevent damage.
- 16) The appliance is not intended for use by young children or infirm persons without supervision.
- 17) Young children should be supervised to ensure that they do not play with the appliance.
- 18) If the supply flexible cord is damaged, it must be replaced by the manufacturer or its service agent or a similarly qualified person in order to avoid a hazard.

SAVE THESE INSTRUCTIONS

For Future Use

DANGER

Risk of child entrapment.

Before you throw away your old refrigerator or freezer, take off the door and leave the shelves in place so that children may not easily climb inside.

Thank you for using our Haier product. This easy-to-use manual will guide you in getting the best use of your freezer.

Remember to record the model and serial number. They are on a label on the back of the freezer.

Model number

Serial number

Staple your receipt to your manual. **You will need it if warranty service is required.**

Date of purchase

Table Of Contents

PAGE

Safety Precautions	1
Parts And Features	4
Installing Your Freezer	5
Unpacking Your Freezer.....	5
Adjusting Your Freezer.....	5
Proper Air Circulation.....	5
Electrical Requirements.....	6
Use of Extension Cord	6
Installation Limitations	6
Freezer Features And Use	7
Operating Your Freezer.....	7
General Features.....	7
Fast Freeze	7
Defrosting And Draining.....	8
Installing Castors.....	8
Food Storage Information.....	9
Normal Operating Sounds.....	9
Proper Freezer Care and Cleaning	10
Cleaning and Maintenance.....	10
Power interruptions	11
Vacation and Moving Care.....	11
Troubleshooting	12
Warranty information	13

Parts And Features

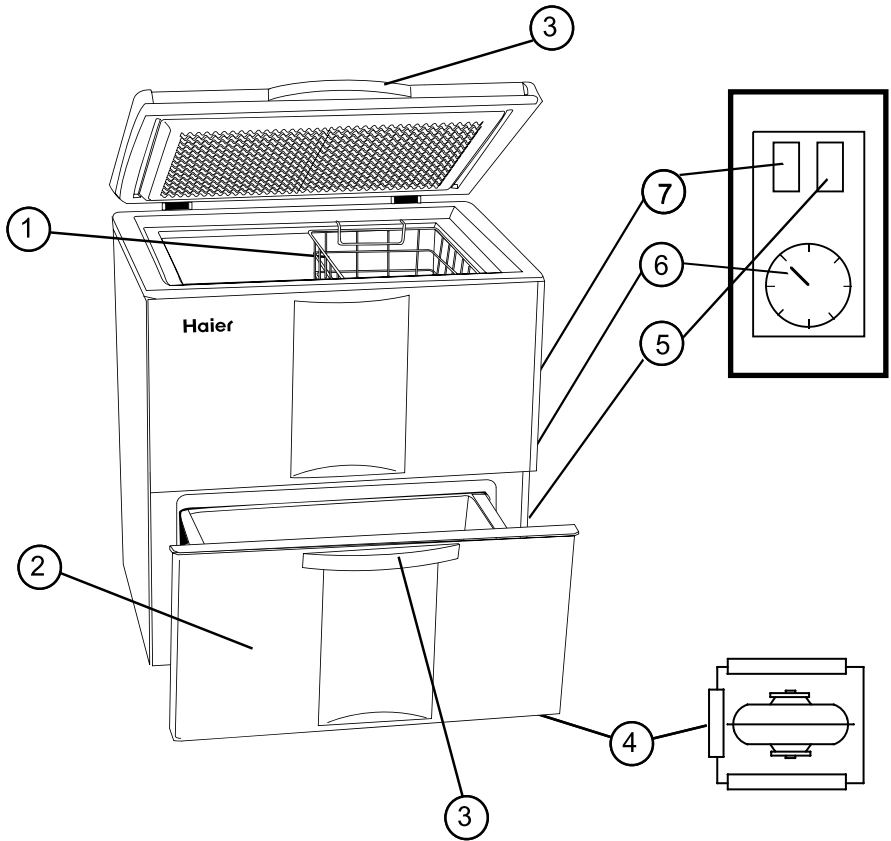

1. Food Basket
2. Bottom drawer
3. Handle
4. Castors (quantity 4)
5. Fast Freeze (orange light switch)
6. Temperature Control Adjustment
7. Power ON Light (green light)

Installing Your Freezer

Unpacking Your Freezer

1. Remove all packaging material. This includes the foam base and all adhesive tape holding the freezer accessories inside and outside.
2. Inspect and remove any remains of packing, tape or printed materials before turning the freezer on .

Adjusting Your Freezer

- Your freezer is designed for freestanding installation only. It should not be recessed or built-in.
- Place the freezer on a floor strong enough to support it fully loaded.
- When moving the freezer, never tilt it more than a 45-degree angle. This could damage the compressor and the sealed system.
- If the freezer is tilted let it stand in an upright position for at least 24 hours before turning on. This will allow the refrigerant to settle.

Proper Air Circulation

- To assure your freezer works at the maximum efficiency, you should install it in a location where there is proper air circulation and electrical connections.
- The following are recommended clearances around the refrigerator:
Sides.....4" (102mm)
Top.....4" (102mm)
Back.....4" (102mm)

Electrical Requirement

- Make sure there is a suitable power Outlet (220-240 volts, 15 amps outlet) with proper grounding to power the freezer.
- Avoid the use of multi plug adapters.

Use of Extension Cord

- Avoid the use of an extension cord.
If it is necessary to use an extension cord, use only a 3-wire extension cord that has a 3-blade grounding plug and a 3-slot outlet . The marked rating of the extension cord must be equal to or greater than the electrical rating of the appliance.

Installation Limitations

- Do not install your freezer in any location not properly insulated or heated e.g. garage etc. Your freezer was not designed to operate in temperatures below 12 deg C.
- Select a suitable location for the freezer on a hard even surface away from direct sunlight or heat source e.g. radiators, baseboard heaters, cooking appliances etc. Any floor unevenness should be corrected.

Freezer Features And Use

Operating Your Freezer

- Once the freezer is in its proper place, plug it into an electrical outlet having 220-240 volts and 15 amps.
- Set the temperature, on the temperature control knob. '1' being the warmest and '6' being the coldest. Initially set the temperature to '4' and place food inside the freezer, after running for 24 hours reset the freezer if necessary to your desired setting.
- If you unplug the freezer or experience an electrical outage, always allow 5 minutes before plugging it back in.

General Features

Adjustable temperature dial:

Your freezer will automatically maintain the temperature level you select. The temperature control dial has 6 settings plus OFF. '1' is the warmest, '6' is the coldest. Turning the dial to OFF, turns the compressor off. Set the dial to '4' and allow 24 hours for the freezer to settle, this is the 'normal' setting.

(Note: If the freezer has been placed in a horizontal or tilted position for any period of time wait 24 hours before plugging the unit in.)

Fast Freeze

- Your freezer may be equipped with a Fast Freeze switch (orange switch), which will allow you to deep freeze food when you have added a lot of food at one time. Flip the orange Fast Freeze switch on and the compressor will run continuously.

Note: **Turn the Fast Freeze feature off once food has reached desired temperature.**

Doing so will avoid unnecessary energy use.

Defrosting and Draining The Freezer

- Defrost whenever the frost becomes 1/ 4" thick. Never use a sharp or metallic instrument to remove the frost as it may damage the cooling coils or liner. (A punctured coil or liner will void the warranty)
- Turn the temperature control to OFF position and unplug the unit. Defrosting usually takes a few hours. To defrost faster keep the freezer lid and drawer open.
- Wipe the interior of the freezer, replace the electrical plug and turn on at the electrical outlet.
- Reset the temperature control to the desired setting.

Installing Castors

- Castors are to be installed on the 4 bottom corners. Slide castor in the provided slot. Once the castor is in place, secure it with a screw provided.

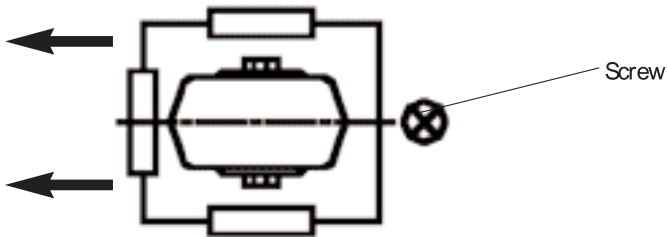

Note: 1 Phillips Head screwdriver required.

Food Storage Information

Frozen Food:

- Wipe containers before storing to avoid them sticking to each other or to the interior of the freezer.
- Hot food should be allowed to cool before storing in the freezer. This will prevent unnecessary energy use.
- When storing meats, keep in the original packaging or rewrap as necessary.
- Proper freezer storage requires correct packaging. All foods must be in packages, which do not allow the flow of air or moisture in, or out. Improper storage will result in odor and taste transfer and will dry out food and reduce its quality and storage life.
- Follow package or container instructions for proper storage.
- Depending on the external environment, selected thermostat setting, and the individual usage habits, the temperature range is:
-10°C to -25°C for the top section.
-7°C to -17°C for the bottom drawer.

TOP COMPARTMENT

The top compartment is for Deep Freeze and Super Freeze of fresh produce. The normal operating temperature is -15 degrees C but it can be adjusted lower. The Super Freeze function is designed to preserve the nutritional value and flavour of the food.

PULL OUT DRAWER

The unique Pull out Drawer operates at a temperatures of -7 degrees C or lower and is ideal storage for pre-frozen food, for imminent use.

- **Packaging Recommendations:**
Plastic containers with air tight lids
Heavy duty aluminum foil
Self-sealing plastic bags
- Do not refreeze defrosted or thawed foods.
- It is recommended that the freezing date be marked on the packaging.

Proper Freezer Care and Cleaning

Cleaning and Maintenance

Warning:

To avoid electric shock always unplug your freezer before cleaning .

Caution:

Before using cleaning products, always read and follow manufacturer's instructions and warnings to avoid personal injury or product damage.

General:

- Prepare a cleaning solution of 3-4 tablespoons of baking soda mixed with warm water. Use sponge or soft cloth, dampened with the cleaning solution, to wipe down your freezer.
- Rinse with clean warm water and dry with a soft cloth.
- Do not use harsh chemicals, abrasives, ammonia, chlorine bleach, concentrated detergents, solvents or metal scouring pads. Some of these chemicals may dissolve, damage and/ or discolor your freezer.

Door Gaskets:

- Clean lid and drawer gaskets every three months according to general instructions. Gaskets must be kept clean and pliable to assure a proper seal.
- Petroleum jelly applied lightly on the hinge side of gaskets will keep the gasket pliable and assure a good seal.

Power Interruptions

- Occasionally there may be power interruptions due to thunderstorms or other causes. Remove the plug from the AC outlet when a power outage occurs. When power has been restored, refit the plug into the AC outlet. If the outage is for a prolonged period, inspect the food and discard any spoiled or thawed items. Clean freezer before reusing.

Vacation and Moving Care

- For long vacations or absences, empty food from freezer, move the temperature DIAL to the OFF position and clean the door gaskets according to "General cleaning" section. Prop door open, so air can circulate inside. When moving the freezer always keep it vertical, laying it down may cause damage to the sealed system.

Normal Operating Sounds You May Hear

- Boiling water gurgling sounds or slight vibrations that are the result of the refrigerant circulating through the cooling coils.
- The thermostat control will click when it cycles on and off.

Trouble shooting

Freezer Does Not Operate:

- Check if thermostat control is in the “OFF” position.
- Check if freezer is plugged in.
- Check if there is power at the ac outlet, by checking the circuit breaker or by trying another appliance in the outlet.
- Wait for 30-40 minutes to see whether freezer will start. Compressor cycle must be complete to operate.

Food temperature appears too warm:

- Frequent lid and/or drawer openings.
- Allow time for recently added warm food to reach freezer temperature.
- Check gaskets to ensure they are sealing properly.
- Adjust temperature control to colder setting.

Food temperature is too cold:

- If temperature control setting is too cold, adjust to a warmer setting and allow several hours for temperature to adjust.

Freezer runs too frequently:

- This may be normal to maintain constant temperature during high temperature and humid days.
- The lid or drawer may have been opened frequently or for an extended period of time.
- Check gaskets to ensure they are sealing properly.
- Check to see if the lid and drawer are completely closed.

Freezer has an odour:

- Interior needs cleaning.
- Foods improperly wrapped or sealed are giving off odours.

Limited Warranty

What is covered and for how long?

This warranty covers all defects in workmanship or materials for a period of:

**24 months parts and labour
additional 3 years sealed system**

The warranty commences on the date the item was purchased and the original purchase receipt must be presented to the authorised service centre before warranty repairs are commenced.

What is covered.

1. The mechanical and electrical parts, which serve a functional purpose for the appliance, are covered for a period of 24 months. This includes all parts except finish, and trim.
2. The components of the sealed system e.g. hermetic compressor, condenser and evaporator are covered from manufacturing defects for a period of 5 years from the date of purchase. Any damage to such components caused by mechanical abuse or improper handling or shipping will not be covered.

What will be done?

1. We will repair or replace, at our discretion any mechanical or electrical part, which proves to be defective in normal usage during the warranty period specified.
2. Contact the HAIER customer service department for the name of your nearest Authorised Service Centre on :
1300 729 948

THIS WARRANTY ONLY COVERS APPLIANCES WITHIN AUSTRALIA . IT DOES NOT COVER THE FOLLOWING

Damage from improper installation.
Damage in shipping.
Defects other than manufacturing.
Damage from misuse, abuse, accident, alteration or lack of proper care and maintenance.
Damage due to incorrect current or voltage.
Damage from other than household use.
Damage from service by other than an authorised dealer or service centre.
Decorative trims or light bulbs.
Transportation and shipping.
Labour (after the initial 24 months).

THIS LIMITED WARRANTY IS GIVEN IN LIEU OF ALL OTHER WARRANTIES, EXPRESSED OR, INCLUDING THE WARRANTIES OF MERCHANTABILITY AND FITNESS FOR A PARTICULAR PURPOSE

The remedy provided in this warranty is exclusive and is granted in lieu of all other remedies.

This warranty does not cover incidental or consequential damages, so the above limitations may not apply to you.

This warranty gives you specific legal rights, you may also have other rights, which may vary.

Haier Australia Pty Ltd

IMPORTANT

Do Not Return This Product To The Store

If you have a problem with this product, please contact the "Haier Customer

Satisfaction Centre" on 1300 729 948 .

DATED PROOF OF PURCHASE REQUIRED FOR WARRANTY SERVICE

Made in China

Haier

Printed in China