

KFN91..

en Operating and installation instructions

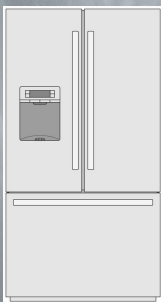

BOSCH

en Table of Contents

Safety and warning information	3
Directions for disposal	4
Scope of delivery	4
Installation notes	4
Note the ambient temperature and ventilation	5
Installing and connecting up the appliance	5
Appliance and installation dimensions	9
Getting to know the appliance	10
Control elements	11
Notes on using the appliance	12
Switching on the appliance	12
Setting the temperatures	12
Alarm function	12
Childproof lock	13
Supercool function	13
Superfreeze function	13
quick ice	13
Water filter symbol	13
Unit of temperature	14
Fridge compartment	14
HydroFresh drawers	14
Delicatessen drawer	14
Variable layout of inside	15
Freezer compartment	16
Freezing foods	16
Buying and storing deep-frozen foods	16
Thawing out frozen food	16
Features of the freezer compartment	17
Ice and water dispenser	17
Water filter	19
Specification and performance data sheet	20
Saving energy	21
Operating noises	21
Defrosting	21
Switching the appliance off and placing it out of operation	21
Cleaning	21
Lighting (LED)	22
Repairing minor malfunctions yourself	23
Customer services	25

Safety and warning information

Before operating the appliance

Read the instruction and installation manual carefully.

They contain important information on setting up, using, and maintaining the appliance.

Retain all documents for later use or for subsequent owners.

Safety

If the appliance's mains cable is damaged, it must be replaced by the manufacturer, customer services, or a similarly qualified person. Improper installation and repair jobs can place the user in considerable danger.

Repairs may only be carried out by the manufacturer, customer services, or a similarly qualified person.

Only original parts of the manufacturer may be used. The manufacturer only guarantees that the safety requirements are met if these parts are used.

A mains cable extension lead may only be procured via customer services.

During operation

- Never use electrical appliances inside the appliance (e.g. heaters, electric ice makers).
Risk of explosion!
- Never defrost or clean the appliance with a steam cleaner. Steam can come into contact with electrical parts and cause a short circuit or an electric shock.
Risk of electric shock!
- Do not use pointed or sharp objects to remove layers of ice and frost! Doing so can damage the refrigerant pipes. If refrigerant sprays out, it can ignite or cause eye injuries.
- Do not store products with flammable propellant gases (e.g. spray cans) or explosive substances inside the appliance.
Risk of explosion!
- Do not use base, drawers, doors, etc. as steps or supports.
- When defrosting and cleaning the appliance, disconnect the mains plug or switch off the circuit breaker. Tug on the mains plug, not on the cable.
- Store high percentage alcohol only in tightly closed containers and upright.
- Do not soil plastic parts and the door seal with oil or grease. If you do so, the plastic parts and door seal will become porous.
- Never cover or block ventilation openings on the appliance.
- Children and people with impaired physical, sensory, or mental abilities or who lack knowledge of the appliance must only use it if they are supervised by a person who will take responsibility for their safety or who have learned how to use the appliance by reading this manual.
- Do not store liquids in bottles or cans in the freezer compartment (in particular carbonated beverages). Bottles and cans may burst.
- Never eat frozen foods immediately after they have been taken out of the freezer compartment.
Risk of freezer burn!
- Avoid prolonged contact of your hands with frozen foods, ice, and the evaporator tubes etc.
Risk of freezer burn!

Children in the household

- Do not give packaging or packaging parts to children.
Danger of suffocation from cardboard boxes and films!
- This appliance is not a toy!
- For appliances with a door lock: Keep the key out of the reach of children!

General requirements

The appliance is suitable for the following tasks:

- Chilling and freezing food,
- Making ice cubes,
- Dispensing drinking water.

This appliance is intended for domestic use in private households and for a domestic environment.

The appliance is fitted with interference suppression in accordance with EU Directive 2004/108/EC.

The refrigerant circuit has been tested for leaks.

This appliance corresponds to the relevant safety requirements for electrical appliances (EN 60335/2/24).

Directions for disposal

Disposal of packaging

The packaging protects your appliance against damage during transport. All materials used are environmentally compatible and reusable. Please help: dispose of the packaging in an environmentally friendly manner.

For current methods of disposal, please contact your dealer or the local authorities.

Disposal of old appliances

Old appliances are not valueless waste.

Valuable raw materials can be recovered through environmentally responsible disposal.



This appliance is in accordance with European Directive 2002/96/EC on old electrical and electronic appliances (Waste Electrical and Electronic Equipment - WEEE). The guideline provides a valid framework for recovering and utilising old appliances throughout the EU.

Warning!

Handle worn out appliances as follows:

1. Unplug the mains plug.
2. Cut the power cord and remove along with the mains plug.
3. Do not remove the shelves and containers. Leaving them intact makes it more difficult for children to climb in!
4. Never let children play with a worn out appliance.

Risk of asphyxiation!

Refrigerators contain refrigerants and the insulation contains gases. Refrigerants and gases must be disposed of properly. Do not damage refrigerant tubing until such time when it can be disposed of properly.

Scope of delivery

After unpacking the appliance, check all parts for transport damage.

If you wish to make a complaint, please contact the dealer from whom you purchased the appliance or customer services.

The scope of delivery includes the following parts:

- Refrigerator and freezer unit,
- Features (vary depending on the model),
- Water connection hose,
- Usage and assembly instructions,
- Guarantee slip,
- Information on energy consumption and noises,
- Bag of assembly materials.

Installation notes

Transport and installation

This appliance is heavy and must be secured during transport and fitting.

Warning!

This appliance is very heavy. If the appliance falls over during transport and installation work, it can cause serious injuries. At least two people are required to install the appliance safely. Keep the doors of the appliance shut until the appliance is positioned and level at its installation location.

Installation location

The appliance should be placed in a dry room that can be ventilated. The installation location should not be directly exposed to the sun and should not be near a heat source such as a stove or radiator. If installation next to a heat source is unavoidable, use a suitable insulating plate or maintain the following minimum distances from the heat source:

- 3 cm from an electric or gas cooker,
- 30 cm from oil or solid fuel cookers.

If the appliance is being installed next to another refrigerator or freezer, maintain a minimum distance between the sides of the two appliances of 25 mm. This prevents the formation of condensation.

If there is a cover or cupboard above the appliance, there must be a gap of 10 mm to enable the appliance to be pulled out if necessary.

The heated air must be able to escape unimpeded from the rear of the appliance.

If the appliance is being installed in the corner of a room or in a niche, the minimum required gaps (see section "Device and installation dimensions") at the sides of the appliance must be observed so that the doors can be opened all the way.

If adjacent kitchen units are deeper than 75 cm, the minimum required gaps at the side must be observed in order to enable the entire door opening angle to be used (see section "Door opening angle").

Floor surface

Information!

The appliance is very heavy.

The floor at the installation location must not sag. If necessary, reinforce it.

Empty weight:

Basic model

147 kg

Note the ambient temperature and ventilation

The climate class is stated on the nameplate. It specifies the room temperatures suitable for using the appliance. The nameplate is on the right of the appliance.

Climate class	Permissible ambient temperature
SN	+10 °C to 32 °C
N	+16 °C to 32 °C
ST	+16 °C to 38 °C
T	+16 °C to 43 °C

Ventilation

The air from the base panel at the front and cover plate at the rear heats up. The heated air must be able to escape unimpeded. Otherwise, the refrigerating unit has to work harder, which increases the appliance's power consumption. You must therefore never cover or block the ventilation openings.

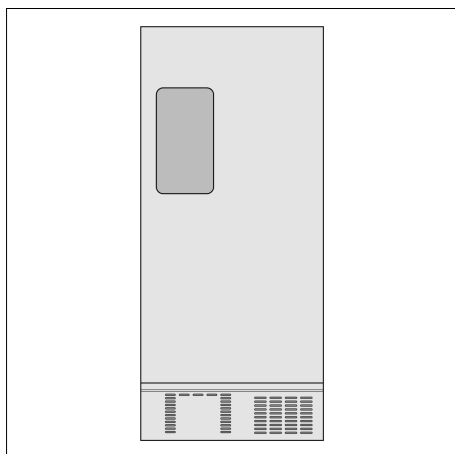

Installing and connecting up the appliance

- The appliance must be installed and connected up by a specialist in accordance with these assembly instructions.
- Once the appliance has been positioned, wait at least 8 hours before plugging in the mains cable. The oil in the compressor can shift to the refrigeration system during transport.
- Before starting the appliance up for the first time, clean its interior (see section "Cleaning the appliance").
- The water line must be connected up before the electrical connections.
- In addition to the statutory national regulations, the connection requirements of the local electricity and water supply companies are to be observed.
- Only remove the transport locks on the trays and racks once the appliance has been installed.
- If the appliance doors need to be removed in order for the appliance to fit through the doors of the house or flat, the doors must be removed by customer services only.

Water connection

⚠ Warning!

Risk of electric shock and of damage to property!

Disconnect the appliance from the electricity mains before carrying out any work on the water connection.

The water connection must only be installed by a qualified plumber in accordance with the regulations governing the plumbing trade and the local waterworks.

Connect the appliance to a drinking water pipeline.

- Minimum pressure: 1.0 bar
- Maximum pressure: 8.2 bar

If the water pressure is more than 8.2 bar, a pressure reducing valve must be integrated. If the water pressure is less than 1.0 bar, the ice maker will not work.

The 3/4" tap for connecting the enclosed connection line must be easily accessible.

The connection line has a 3/4" connector.

The taste and smell of the water can be improved by installing the enclosed filter cartridge. If the filter cartridge is used, pay attention to the different connection conditions (see section "Water filter").

Connecting up the appliance

1. Connect the connection line to the appliance.

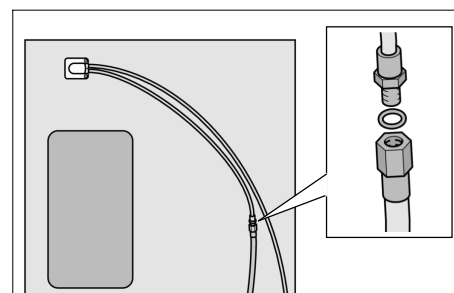

2. Connect the connection line to the water tap.

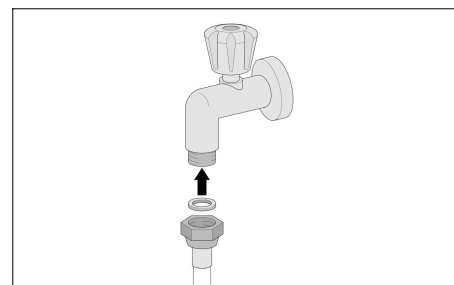

3. Loop or wind the connection line so that the appliance can be moved away from the wall.

Electrical connection

Following the installation of the appliance, wait at least 8 hours before starting it up. The oil in the compressor can shift to the refrigeration system during transport.

Clean the inside of the appliance before it is first used (see section "Cleaning").

The socket must be near to the appliance and easily accessible, even after the appliance has been moved into place.

Connect the appliance to a 220-240 V/50 Hz alternating current via a properly installed socket with an earth wire. The socket must have a 10 A - 16 A fuse.

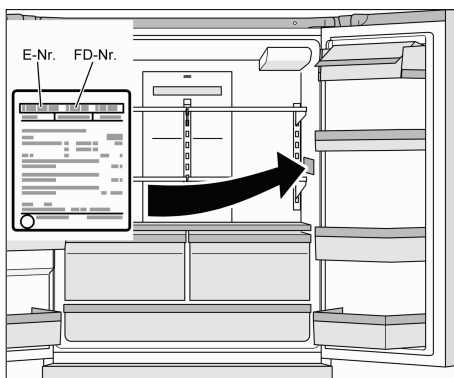

In the case of appliances operated outside Europe, check whether the voltage and type of current specified on the nameplate conform to the values of your electricity grid. This information is located on the nameplate.

⚠ Warning!

In no circumstances may the appliance be connected up to an electronic energy saving socket.

Sine- and line-commutated inverters can be used with our appliances. In the case of isolated installations in holiday homes or on boats, for example, you must use a sine-commutated inverter.

Aligning the appliance

Information!

So that it functions properly, the appliance must be set level using a spirit level.

An improperly aligned appliance can result in water running out of the ice maker, ice cubes of different sizes being made, or the doors not closing properly.

1. Place appliance at the intended location.

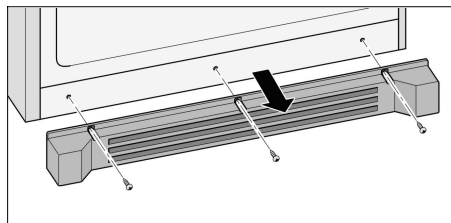

2. Unscrew the three screws on the base panel.
3. Remove the base panel.
4. Use an Allen key to screw the two front feet out until they stand firmly on the ground and align the appliance at the front.

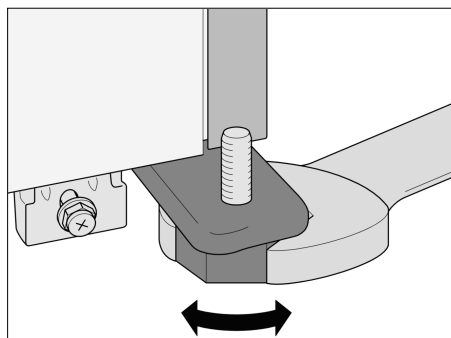

5. Use an Allen key to turn the screws and align the appliance at the rear.

Raise the appliance at the rear:
Turn the screw clockwise.

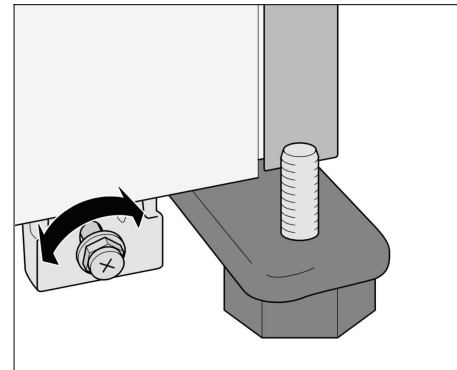

Lower the appliance at the rear:
Turn the screw anticlockwise.

6. Check for horizontal alignment of the appliance using a spirit level.

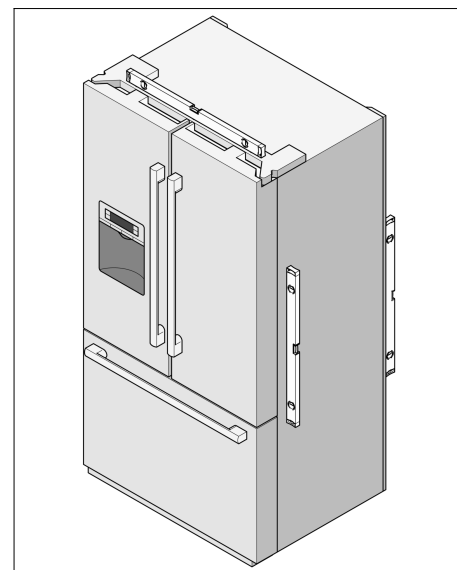

Information!

The front feet must stand firmly on the ground so that the appliance does not roll away.

7. If the fridge compartment doors or freezer drawer have an uneven height or are on a slant once the appliance has been aligned, align them as described below.

Aligning the fridge compartment door

If the top and bottom edges of the two fridge compartment doors are not at the same level, proceed as follows:

1. Determine which fridge compartment door needs to be raised.
2. Use the nut on the lower mount to align the fridge compartment door.

To raise the fridge compartment door:
Turn the screw anticlockwise.

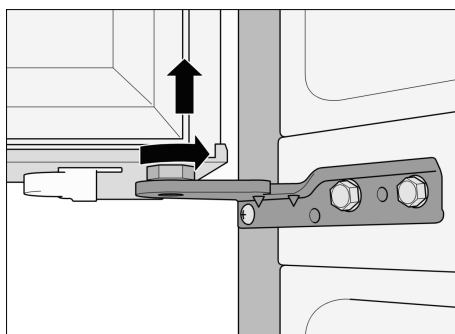

To lower the fridge compartment door:
Turn the screw clockwise.

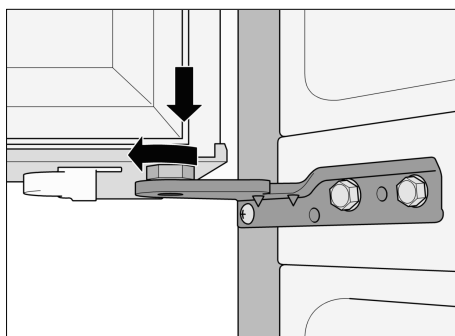

If the fridge compartment doors are on a slant, proceed as follows:

⚠ Warning!

Risk of electric shock!

Before removing the top panel: interrupt the supply of water to the appliance. Pull out the mains plug or disable the fuse.

1. Determine which fridge compartment door needs to be adjusted.
2. Unscrew the five screws on the top panel.
3. Raise the panel.

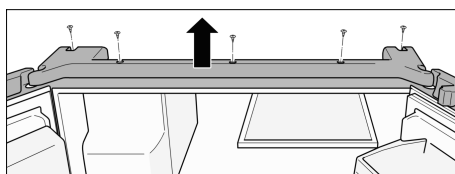

4. Loosen the screws.
Do not take the screws out!

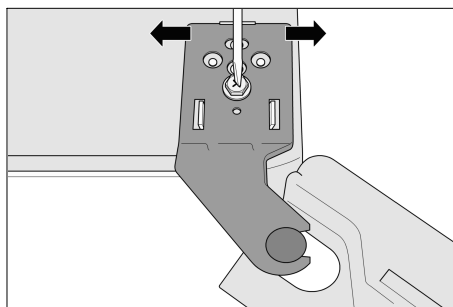

5. Align the fridge compartment door by moving the mount to the side.
6. Tighten the screw.
7. Position the panel.
8. Position and tighten the five screws.

Aligning the freezer drawer

1. Determine which side needs to be adjusted.
2. Loosen the two screws.
Do not take the screws out!



3. Align the freezer drawer using the top screw.
4. Tighten the two screws.

Attaching the handles

Only attach the handles once the appliance has been positioned in its installation location and has been aligned so that it is level.

All of the handles are the same.

There are two protective sheets enclosed with the appliance for attaching and removing the handles. These sheets can be reused.

The protective sheets protect the surfaces during the attachment and removal of the handles.

Information!

If the handles are incorrectly positioned, they cannot be pushed in the specified direction.

Position the handles properly as follows:

It must be possible to push the handles for the fridge compartment doors downwards.

It must be possible to push the handle for the freezer compartment drawer to the right.

If the handles are hard to push, carefully tap them with a rubber hammer.

1. Remove the protective sheets from the fridge compartment doors and the freezer compartment drawer.
2. Attach the protective sheets.

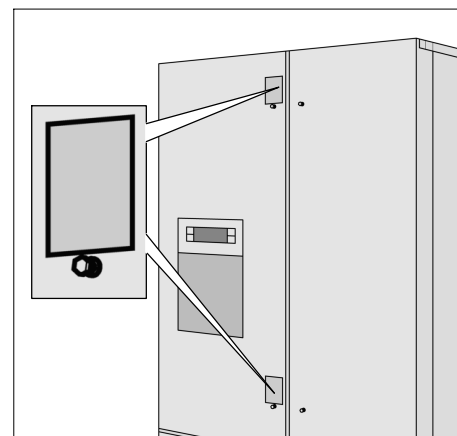

3. Position the handles for the fridge compartment doors on the guides.
4. Slide the handles downwards until they snap into place.

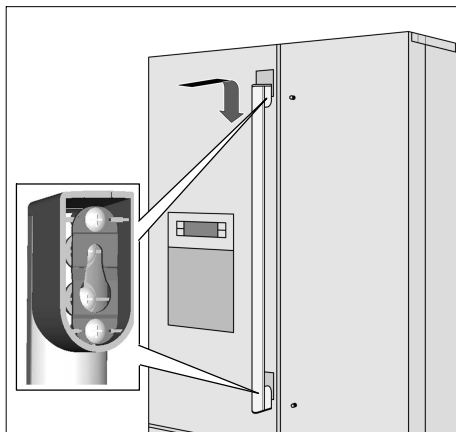

5. Attach the protective sheets.

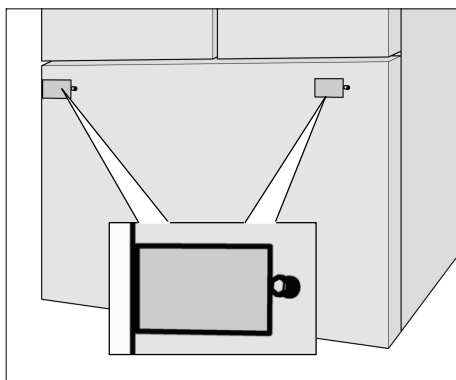

6. Place the handle for the freezer compartment drawer onto the guides.
7. Slide the handle to the right until it snaps into place.

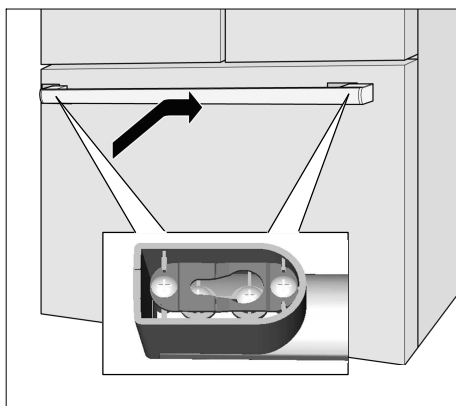

8. Remove the protective sheets and keep them for reuse.

Removing the handles

Information!

To avoid scratching the surface, attach the protective sheet a little below the handle so that it is not pushed to the side by the handle.

1. Attach the protective sheets as follows:
 - To the fridge compartment doors above the guides.

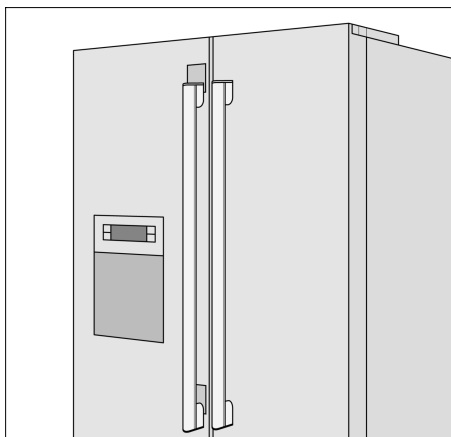

- To the freezer compartment drawer to the left of the guides.

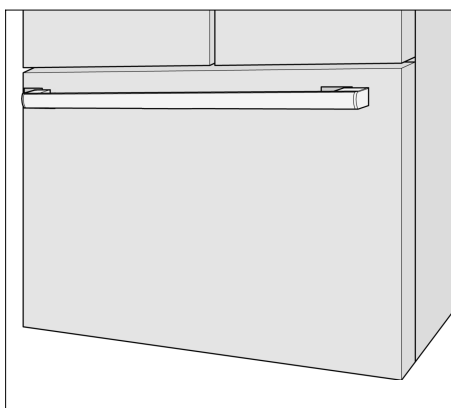

2. Push the handles for the fridge compartment doors upwards and remove them.
3. Push the handle for the freezer compartment drawer to the left and remove it.
4. Remove the protective sheets and keep them for reuse.

Fitting the base panel

1. Unscrew the three screws on the device.
2. Position the base panel.
3. Position and tighten the three screws.

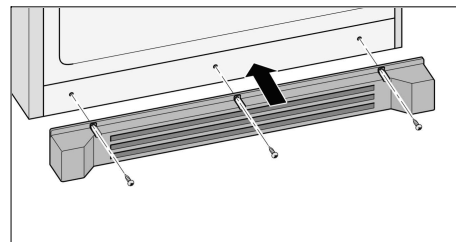

Appliance and installation dimensions

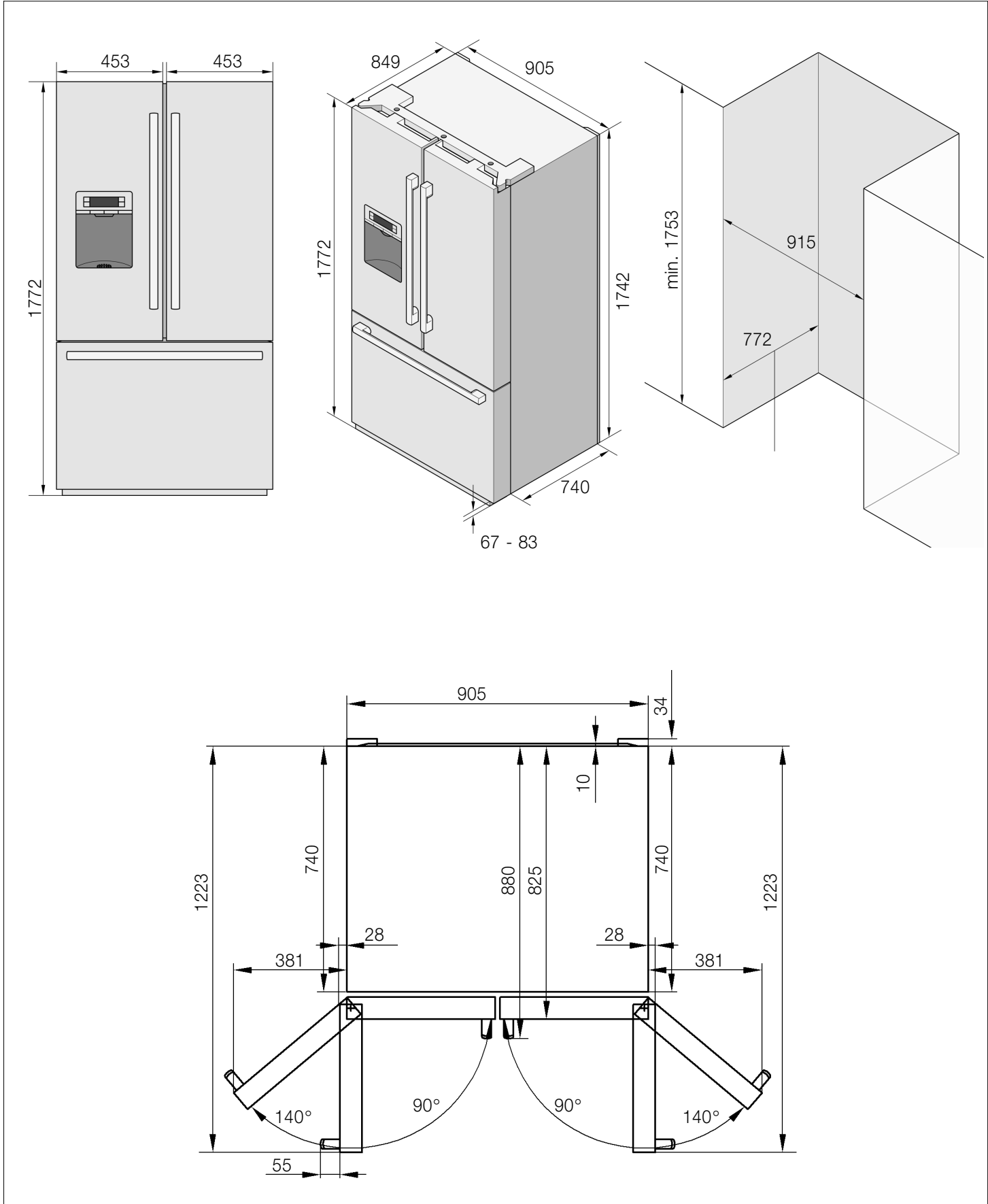

Getting to know the appliance

This instruction and installation manual applies to several models. Your model may be different to the model shown in the illustrations.

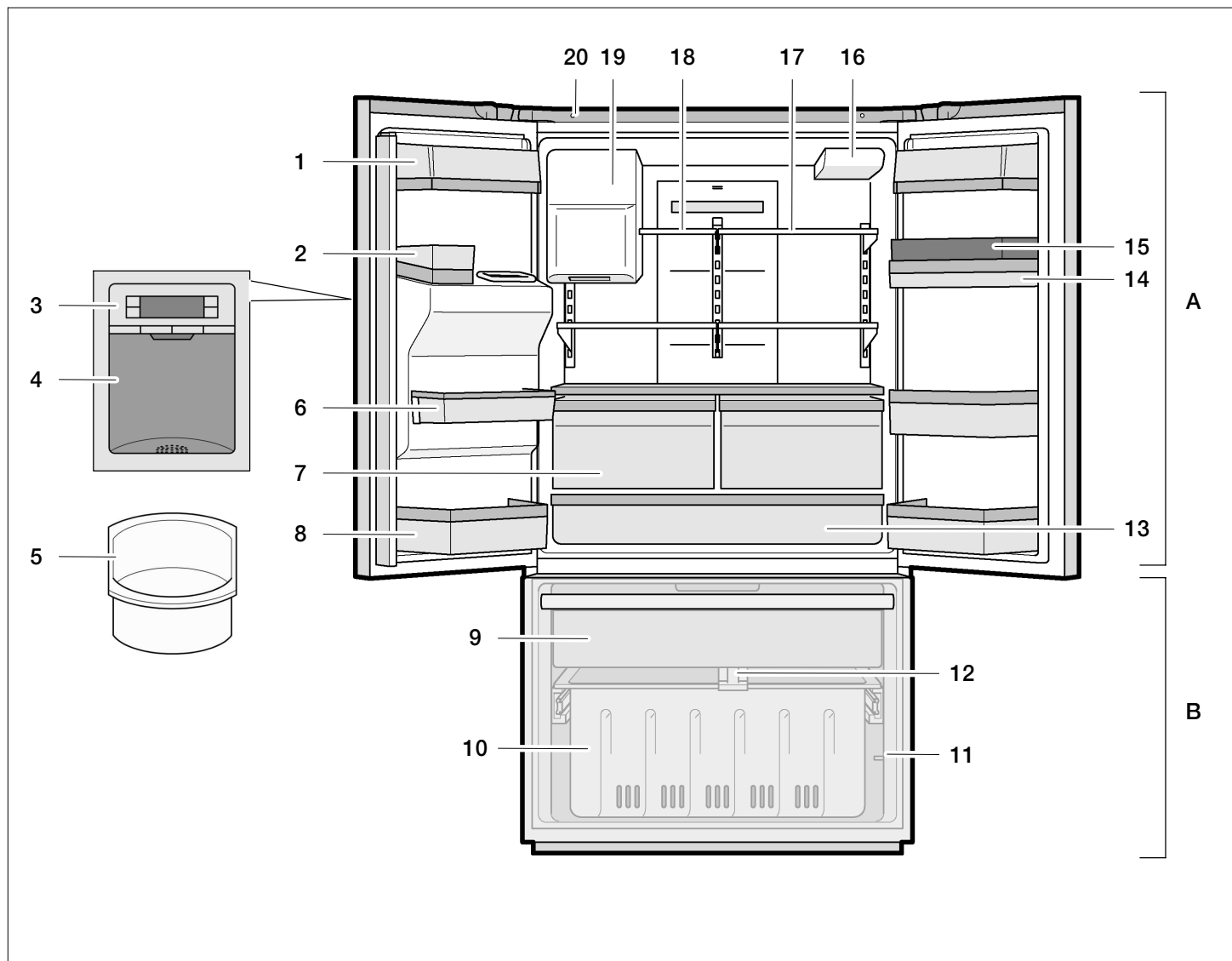

A Fridge compartment can be adjusted between +2 °C and +8 °C

B Freezer compartment can be adjusted between -15 °C and -22 °C

- | | |
|---|---|
| 1 Butter and cheese compartment | 11 Freezer compartment light switch |
| 2 Can holder | 12 Freezer compartment divider |
| 3 Control elements | 13 Delicatessen drawer with lighting (LED) |
| 4 Ice and water dispenser | 14 Door rack |
| 5 Ice tray | 15 Egg tray |
| 6 Door rack | 16 Water filter |
| 7 HydroFresh drawers with lighting (LED) | 17 Adjustable glass shelf |
| 8 Removable door rack | 18 Small glass shelf |
| 9 Top frozen food drawer | 19 Ice maker/ice cube container |
| 10 Bottom frozen food drawer | 20 Fridge compartment light switch |

Control elements

The control and display panel on the left-hand fridge compartment door is a touch panel.

You touch a key to trigger the corresponding function.

The control and display panel light goes out after around 1 minute if you do not touch a key.

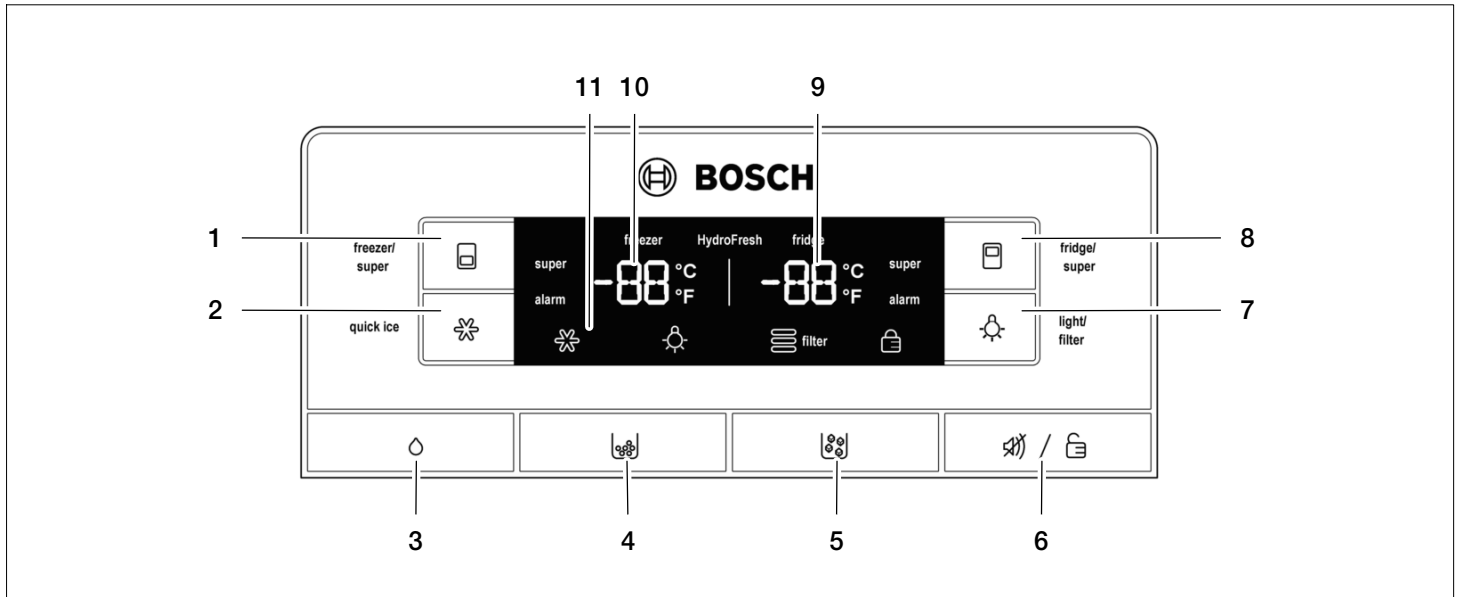

1 "freezer/super" key

- For adjusting the temperature of the freezer compartment.
- For switching the "superfreeze" function on and off.

2 "quick ice" key

For switching the quick ice cube production function on and off.

3 Water dispenser key

4 Crushed ice dispenser key

5 Ice cube dispenser key

6 "alarm/lock" key

- For switching off the warning tone.
- For switching the child lock on and off.

7 "light/filter" key

- For switching the light for the ice and water dispenser on and off.
- For resetting the filter display.

8 "fridge/super" key

- For adjusting the temperature in the fridge compartment.
- For switching the "supercool" function on and off.





9 Fridge compartment temperature indicator

Displays the set temperature for the fridge compartment.

10 Freezer compartment temperature indicator

Displays the set temperature for the freezer compartment.

11 Symbols on the display panel

-  **"quick ice"**
Quick ice function switched on.
-  **"lighting"**
Ice and water dispenser light switched on.
-  **"Water filter"**
State of filter cartridge.
-  **"Childproof lock"**
Childproof lock switched on.

Notes on using the appliance

Opening and closing the fridge compartment doors

The fridge compartment doors can be opened and closed independently of one another.

There is a hinged door strut on the left-hand door of the fridge compartment.

Information!

The door strut can be damaged if you try to close the left-hand fridge compartment door when the door strut is folded out.

Before closing the fridge compartment doors, ensure that the door strut is folded in at a right angle to the door.

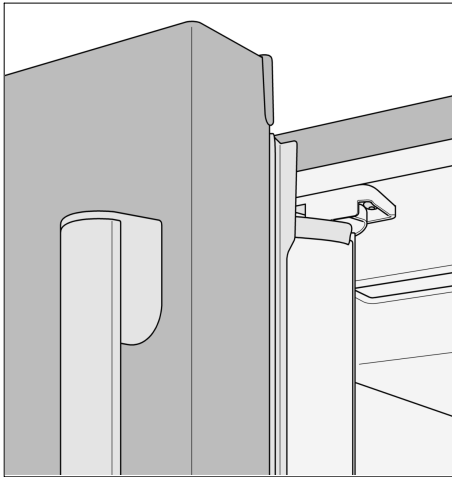

When you close the left-hand fridge compartment door, the door strut folds behind the right-hand fridge door and forms the seal between the doors.

Switching on the appliance

Information!

Following the installation of the appliance, wait at least 8 hours before starting it up. The oil in the compressor can shift to the refrigeration system during transport.

Plug the mains plug into the socket.

After connecting to the mains, the appliance begins to cool. The interior lights are on when the doors are open.

The preset temperatures are reached after several hours. Do not place food into the appliance before then.

Setting the temperatures

Fridge compartment

(can be adjusted between +2 °C and +8 °C)

Press the "fridge/super" key repeatedly until the required fridge compartment temperature is set.

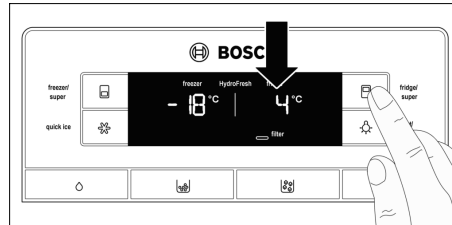

The last set value is saved.

We recommend that you set it to +4 °C.

Perishable foods should not be stored at temperatures of more than +4 °C.

Freezer compartment

(can be adjusted between -15 °C and -22 °C)

Press the "freezer/super" key until the required freezer compartment temperature is set.

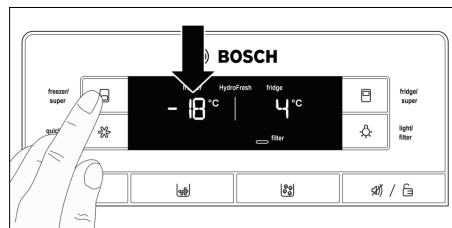

The last set value is saved.

We recommend that you set it to -18 °C.

Alarm function

The warning tone sounds if the appliance is too warm or if the appliance doors are left open for more than three minutes.

The warning tone sounds three times for one minute each time. There is a one minute pause between each warning tone.

Fridge compartment

The display panel indicates "alarm" on the right-hand side.

To switch off the warning tone:

Press the "alarm/lock" key or close the fridge compartment doors.

The "alarm" indicator on the display panel flashes until the temperature approaches the set temperature.

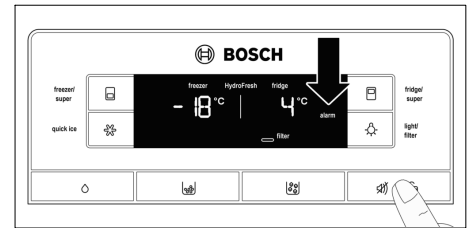

Freezer compartment

The display panel indicates "alarm" on the left-hand side.

To switch off the warning tone:

Press the "alarm/lock" key or close the freezer compartment drawer.

The "alarm" indicator on the display panel flashes until the temperature approaches the set temperature.

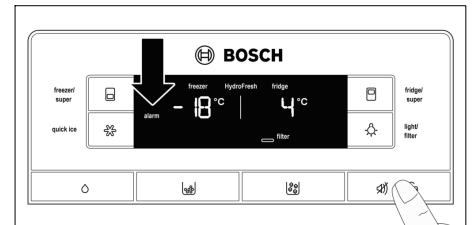

Childproof lock

If the childproof lock function is on, all keys on the control and display panel are locked.

However, even if the childproof lock is on, you can turn off the warning signal if it sounds using the "alarm/lock" key.

To switch the childproof lock on or off:

Press the "alarm/lock" key for 2 seconds.

If the childproof lock function is on, the "childproof lock" symbol appears.

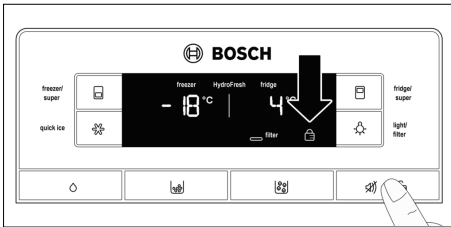

Supercool function

The supercool function chills the fridge compartment as much as possible for approx. 6 hours. It then automatically sets the temperature to +4 °C.

The supercool function is recommended in the following cases:

- Before placing large quantities of food into the fridge.
- For quickly cooling drinks.

To switch on the supercool function:

Press the "fridge/super" key until the display panel indicates "super" on the right-hand side.

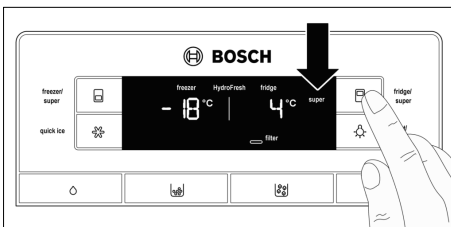

To switch off the supercool function:

Press the "fridge/super" key.

The "super" indicator disappears from the display panel. The temperature is automatically set to +4 °C.

Superfreeze function

Food should be frozen right through as quickly as possible in order to preserve its vitamins, nutritional values, appearance, and taste.

To prevent undesired temperature increases when fresh food is placed into the appliance, switch on the superfreeze function a few hours before inserting the food.

In general, 4 to 6 hours are sufficient. To use the maximum freezing power, switch this function on 24 hours beforehand.

You can freeze smaller quantities of food without using the superfreeze function.

To switch the superfreeze function on:

Press the "freeze/super" key until the display panel indicates "super" on the left-hand side.

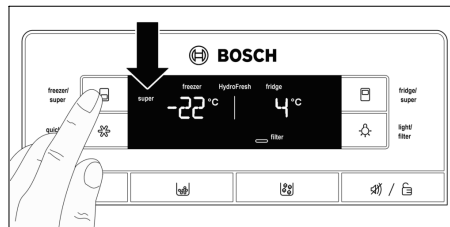

To switch off the superfreeze function:

Press the "freeze/super" key.

The "super" indicator disappears from the display panel. The temperature is automatically set to -18 °C.

Information!

The superfreeze function automatically switches off after 2 days.

quick ice

You can use this function to produce ice cubes quickly.

To switch on the quick ice function:

Press the "quick ice" key.

The display panel shows the "quick ice" symbol.

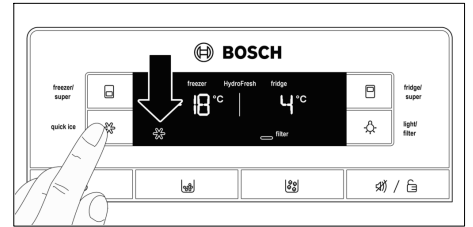

If the ice cube container is full, the quick ice function switches off automatically after a few hours.

Information!

When the quick ice function is switched on, the power of your appliance is increased for a while. As a result, the appliance's energy consumption also increases.

Water filter symbol

The symbol indicates the duration of the usage of the filter.



Up to two months.



Up to four months.



Up to six months.



After six months:
The symbol flashes.
Replace the filter cartridge.

When you switch off the appliance, the water filter symbol is reset.

After changing the filter cartridge, reset the water filter symbol:

Hold down the "light/filter" key for 3 seconds.

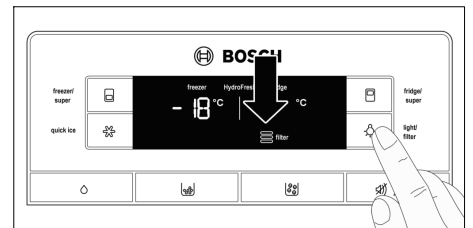

The symbol stops flashing.

Unit of temperature

The temperature can be displayed in degrees Celsius (°C) or in degrees Fahrenheit (°F).

When the device is switched on, the appliance initially displays the temperature in degrees Celsius (°C).

To set the unit of temperature:

Press the "alarm/lock" key for 2 seconds.

The "childproof lock" symbol appears.

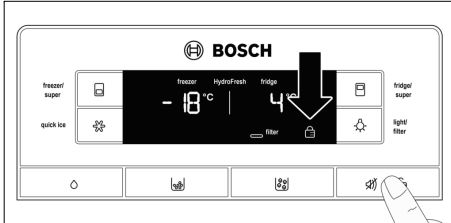

Hold down the "quick ice" key for 15 seconds until the unit of temperature changes.

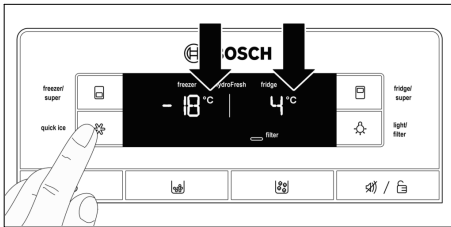

Fridge compartment

The temperature of the fridge compartment can be adjusted between +2 °C and +8 °C.

We recommend that you set it to +4 °C.

Perishable foods should not be stored at temperatures of more than +4 °C.

Use of fridge

Use the fridge to store prepared dishes, bakery products, canned goods, condensed milk, cheese, spreads, sauces, dips, and eggs.

When arranging the food, bear in mind the following:

- Allow warm food and beverages to cool down outside of the appliance.
- Pack food so that it is airtight to prevent it from losing its flavour or drying out.
- Do not block air outlets with food. Doing so impedes the air circulation.
- Do not allow oil or fat to come into contact with plastic parts or with the door seals.

HydroFresh drawers

The temperature in the HydroFresh drawers is kept at around 0 °C. This low temperature provides optimum storage conditions for perishable goods.

Foods can be kept in the HydroFresh drawers for a much longer period of time before spoiling than they can if stored in the normal fridge compartment.

The HydroFresh drawers are covered by a special moisture filter. This special filter optimises the air humidity in the HydroFresh drawers. As a result, the air humidity in the HydroFresh drawers is up to 90 % relative humidity depending on how full they are. This storage atmosphere provides optimum conditions for fresh produce such as vegetables, salad, herbs, and fruit.

Suitable for fresh cooling:

As a general rule, all fresh food that needs to stay fresh as long as possible is suitable. This includes meats and sausages, fresh fish, seafood, milk, butter, soft cheese, crème fraîche, vegetables, and fruit.

Not suitable for fresh cooling:

Fruit and vegetables that are sensitive to the cold, such as tropical fruits, avocado, papaya, passion fruit, aubergine, cucumber, and peppers. Also, fruit that needs to ripen, green tomatoes, and potatoes should not be kept here.

When purchasing food, bear in mind the following:

The freshness of food at the time of purchase is important when determining how long it may be kept. In principle, the following applies: The fresher the produce when it is placed into the HydroFresh drawers, the longer it will keep. When purchasing food, always pay attention to how fresh it is.

Removing the HydroFresh drawers

1. Pull the HydroFresh drawer out as far as possible.
2. Lift the front of the HydroFresh drawer and remove it.

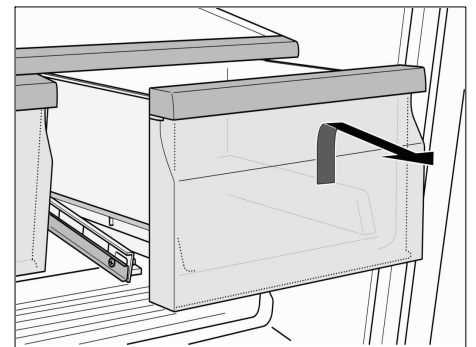

3. Insertion: Insert the HydroFresh drawer into the drawer slide and push it backwards.

Delicatessen drawer

The temperature of the delicatessen drawer is just below freezing. It is suitable for storing meat and sausages, fish, seafood, milk products, and hard or soft cheese.

Information!

Do not store foods that are sensitive to the cold in the delicatessen drawer.

Removing the delicatessen drawer

1. Pull the delicatessen drawer out as far as possible.
2. Lift the front of the delicatessen drawer and remove it.

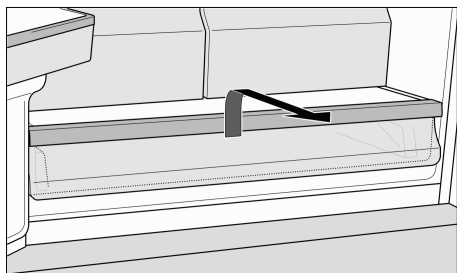

3. Insertion: Insert the delicatessen drawer into the drawer slide and push it backwards.

Variable layout of inside

Glass shelves

The adjustable glass shelves can be removed.

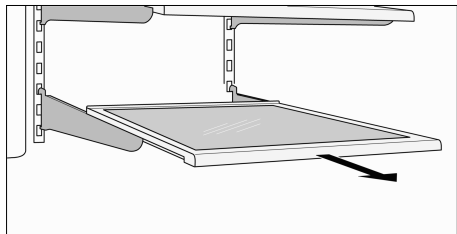

The adjustable glass shelves can be taken out or moved to different heights.

Removing a glass shelf:

Lift the front of the glass shelf and remove it.

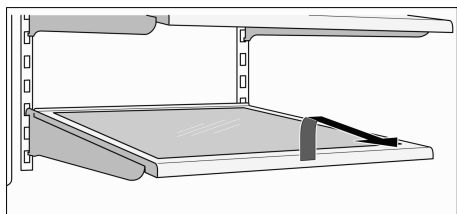

Inserting a glass shelf:

Lift the front of the glass shelf and place the hooks into the openings at the required height. Lower the front of the glass shelf.

Small top glass shelf

You can remove the glass shelf and place it in the holder beneath the ice maker. This allows tall bottles to be stored next to the ice maker, for example.

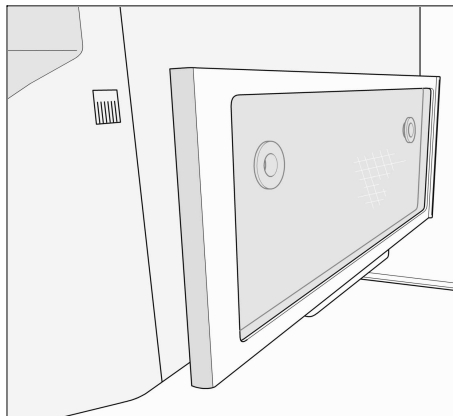

Door racks

To remove a door rack:

Lift the door rack and remove it from the door.

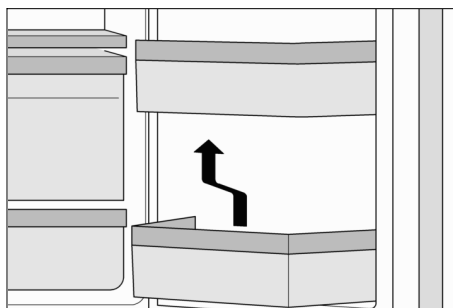

Inserting a door rack:

Position the rack over the holder at the required height and push downwards.

Butter and cheese compartment

To open the butter and cheese compartment, lift its lid upwards.

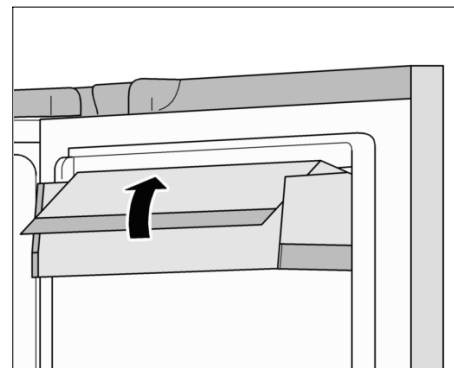

To remove the butter and cheese compartment:

Lift up the butter and cheese compartment and remove it.

To insert the butter and cheese compartment:

Position the rack over the holder at the required height and push downwards.

Egg tray

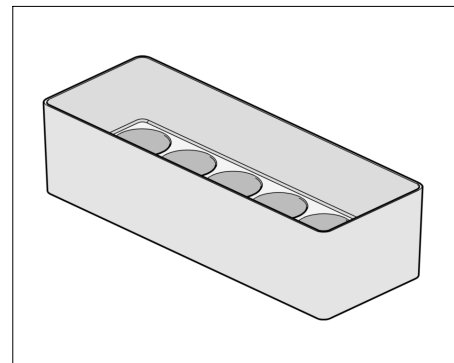

Freezer compartment

The temperature of the freezer compartment can be adjusted between -15 °C and -22 °C.

We recommend that you set it to -18 °C.

Notes on the freezer compartment

- Make sure that the freezer compartment drawer is always closed. If the drawer is open, the frozen food thaws out. The freezer ices up heavily. In addition, energy is wasted due to the high power consumption of the appliance.
- When you close the freezer compartment drawer, there is negative pressure in the freezer compartment.
- If the freezer compartment drawer cannot be opened again soon after being closed, please wait for the negative pressure to disperse.

Use the freezer compartment for the following:

- Storing deep frozen food.
- Freezing food.
- Storing ice cubes.

Freezing foods

Only freeze fresh food in good condition. Do not allow food to be frozen right next to food that has already been frozen. Make sure that foods are packed in airtight packaging so that they do not lose their taste or dry out.

To pack the food correctly:

1. Put the food into the packaging.
2. Squeeze out air completely.
3. Close packaging tightly.
4. Label packaging with its content and date of freezing.

The following are unsuitable for use as packaging:

Wrapping paper, parchment paper, cellophane, reuse bags and used shopping bags.

The following are suitable as packaging:

Plastic films, tubular polyethylene films, aluminium foil, and freezer bags. You can buy these products from your specialist dealer.

For sealing, the following are suitable:

Rubber bands, plastic clips, string, cold-resistant adhesive tape or similar. You can use a heat sealer to seal bags and tubular polyethylene films.

Storage life of frozen food

The storage life of food depends on the food type. The following guidelines apply to a temperature of -18 °C:

- Fish, sausage, prepared dishes, bakery products:
Up to **6 months**
- Cheese, poultry, meat:
Up to **8 months**
- Vegetables, fruit:
Up to **12 months**.

Buying and storing deep-frozen foods

Pay attention when purchasing deep frozen food:

- Make sure that the packaging is not damaged.
- Check the best before date.
- The temperature of the supermarket freezer must be below -18 °C. Otherwise, the storage life of deep-frozen foods is reduced.
- Buy deep frozen foods last. Transport frozen food home in a cold bag or wrapped in newspaper.
- At home put deep frozen food into the freezer compartment immediately. Use up deep frozen food before the best before date.

Thawing out frozen food

Depending upon type of food and the intended use, a choice can be made between the following:

- at ambient temperature,
- in the fridge,
- in an electric oven, with/without hot air convection,
- in the microwave.

Caution!

Do not refreeze slightly or fully thawed frozen food. Such food can only be frozen again after being prepared (boiled or roasted).

Do not fully utilise the maximum storage period for the frozen food.

Features of the freezer compartment

Top frozen food drawer

The frozen food drawer can be removed.

Removing the top frozen food drawer:

1. Pull out the top frozen food drawer as far as possible.
2. Carefully pull out the brackets on both sides and lift the front of the frozen food drawer.
3. Pull the frozen food drawer towards you.

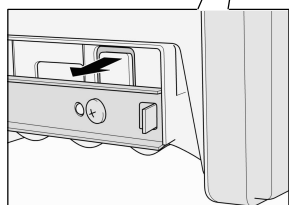
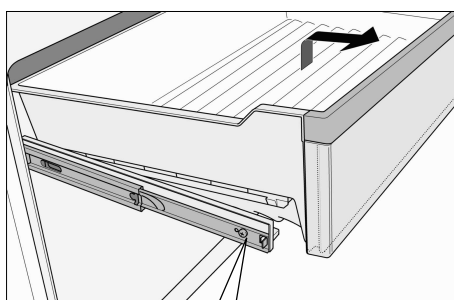

Bottom frozen food drawer

The frozen food drawer can be removed.

Removing the bottom frozen food drawer:

Lift the freezer drawer upwards.

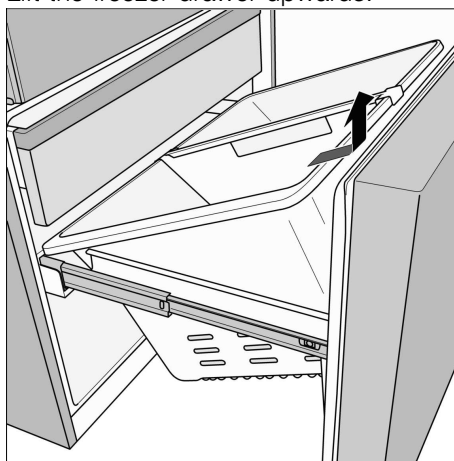

Ice and water dispenser

The following can be dispensed as required:

- Chilled water,
- Crushed ice,
- Ice cubes.

⚠ Warning!

Risk of injuries due to rotating crusher blades!

Do not reach into the ice cube dispenser opening.

Note the following when placing the appliance into operation

The ice and water dispenser only works if the appliance is connected to the water supply.

After placing the appliance into operation, you must wait around 24 hours before the first lot of ice cubes is ready.

After the connections are made, air bubbles are still in the lines. Draw and discard drinking water until the water can be drawn without bubbles. Throw away the first five glasses of water.

When using the ice maker for the first time, throw away the first 30 to 40 ice cubes for hygiene reasons.

Notes on using the appliance

When the freezer compartment has reached its freezing temperature, water flows into the ice maker and freezes to form ice cubes. The finished ice cubes are automatically discharged into the ice cube container.

Occasionally, the ice cubes stick together. During transport to the opening where they are discharged, they usually separate automatically.

Once the ice cube container is full, the ice maker switches off automatically.

The ice maker can produce up to 100 ice cubes in 24 hours assuming that ice cubes are removed several times a day. The quantity produced depends on the room temperature and the appliance's temperature setting.

When ice is being produced, you can hear the water valve, the sound of the water flowing into the ice bowl, and the sound of the ice cubes falling down once they have been produced.

Information!

Do not put bottles or food for fast cooling into the ice cube container. The ice maker can become blocked and damaged.

Pay attention to the quality of the drinking water

Caution!

The supplied water filter only filters out particles from the supplied water, and does not filter out bacteria or microbes.

All materials used in the water dispenser are odourless and tasteless.

If the water has an aftertaste, it may be for the following reasons:

- Mineral and chlorine content of the drinking water,
- Material of household piping or connection line,
- Freshness of drinking water. If no water is drawn for a long time, the water can taste somewhat stale. If this happens, draw and discard around 15 glasses of water.

The taste and smell of the water can be improved by the installation of the supplied water filter in the water inlet.

To dispense water

1. Hold a suitable container under the ice and water dispenser.
2. Press the water dispenser button until the required quantity of water is in the container.

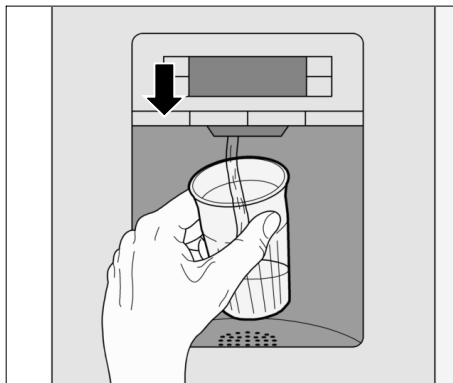

Tip:

The water from the water dispenser is cooled to the proper temperature for drinking. If colder water is desired, place ice cubes in your glass before drawing the water.

Dispensing ice

Information!

Only press the button for dispensing ice cubes or crushed ice long enough to fill half the container with ice. Otherwise, the ice in the ice cube dispenser opening can cause the container to overflow or can block the ice cube dispenser opening.

If crushed ice is dispensed prior to dispensing ice cubes, there may still be some crushed ice in the ice cube dispenser opening. This is dispensed along with the first lot of ice cubes.

1. Hold a suitable container under the ice and water dispenser.
2. Press the ice cube or crushed ice dispenser button until the required quantity of ice is in the container.

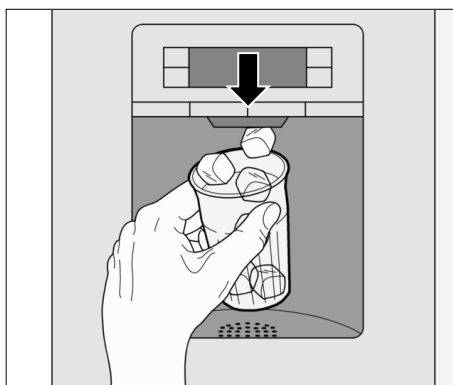

Ice tray

The ice tray is for storing ice cubes that are not required straight away in the freezer compartment. Thanks to its shape, the ice tray fits neatly into the ice and water dispenser.

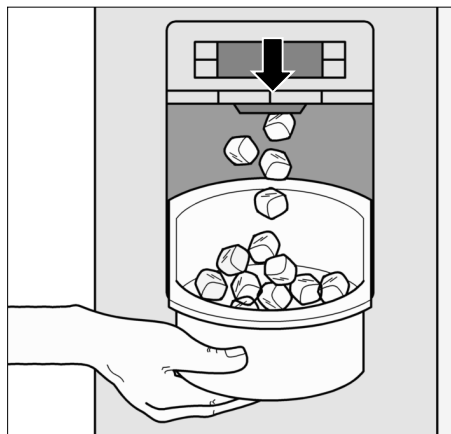

Shutting down the ice maker

Information!

You must interrupt the water supply to the appliance several hours before shutting down the ice maker.

If you do not intend to use any ice cubes for longer than one week (e.g. because you are going on holiday), the ice maker should be shut down for that period in order to prevent the ice cubes from freezing together.

1. Press the release button and remove the ice cube container.

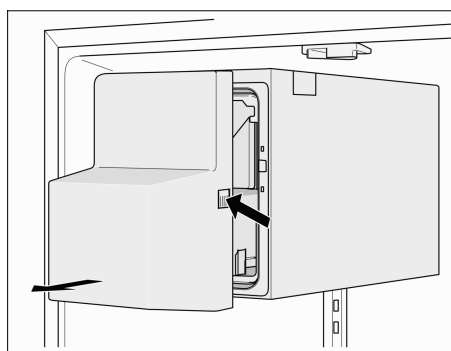

2. Switch off the on/off switch behind the ice cube container (0). The ice maker is now turned off.

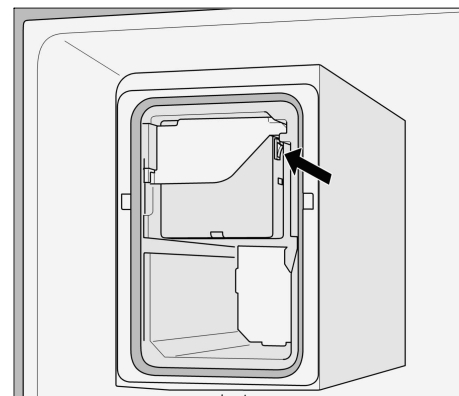

3. Empty and clean the ice cube container.
4. Push the ice cube container right back on the supports until it snaps into place.

To place the appliance back into operation:

- Switch on the on/off button behind the ice cube tray (1). The ice maker is turned on again.

Water filter

You can procure a filter cartridge for the water filter from customer services.

Change the filter cartridge at least every 6 months.

After 6 months, the flashing water filter symbol prompts you to replace the filter cartridge (see section "Water filter symbol").

Caution!

Do not use the appliance in places where the quality of the water is questionable or not sufficiently known without properly disinfecting before and after filtering.

Deviating connection conditions

Filter cartridges cannot be integrated if the water pressure is above 8.2 bar.

A pressure reducing valve must be fitted if the water pressure is above 5.5 bar.

Important information

- If the appliance has not been used for an extended period of time or if the water has an unpleasant taste or smell, flush out the water system. In addition, run the water dispenser for several minutes. If the unpleasant taste or smell persists, replace the filter cartridge.
- The ice maker and water dispenser can be used without the filter cartridge. In this case, install the bypass cap.

Inserting/replacing a filter cartridge

1. Pull the cover forwards and fold down.

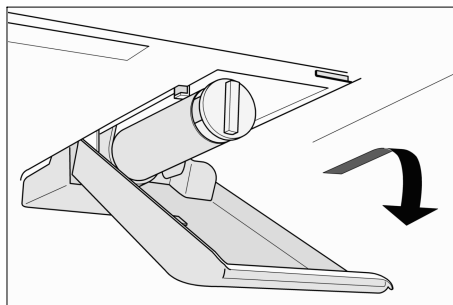

Information!

Be careful when removing the filter cartridge.

The water system is under slight pressure after use.

2. Carefully turn the old filter cartridge or bypass cap 90° anticlockwise.

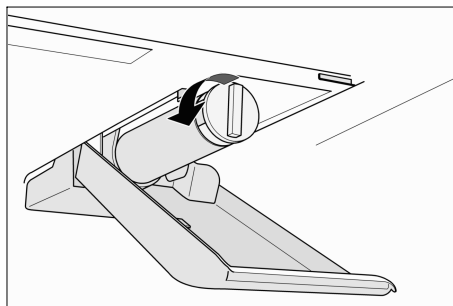

3. Remove the new filter cartridge packaging.
4. Insert the new filter cartridge and carefully turn it 90° clockwise until it snaps into place.
5. Fold the cover upwards and snap into place.
6. Establish the water supply to the appliance.
7. Dispense several litres of water from the water dispenser. This removes air from the water system.

8. Pour out the water from the used filter cartridge. The filter cartridge can be disposed of as household refuse.

9. Hold down the "light/filter" button for 3 seconds. The water filter symbol is reset. The symbol stops flashing. The new filter cartridge is activated.

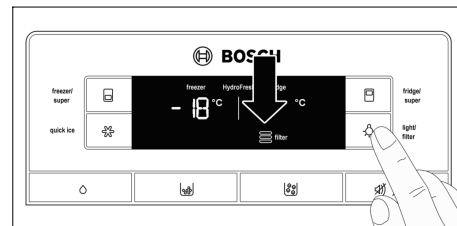

Specification and performance data sheet

For filter models 9000 077 095 and 9000 077 096

Using replacement cartridge 9000 077 104

This model was tested by NSF International as per ANSI/NSF Standards 42 & 53 and was certified for the reduction of the substances listed below.

The concentration of the specified dissolved substances in the water that reach the system was reduced to a value equal to or below the permitted limit value as stipulated by NSF/ANSI 42 and 53 for water drawn from the appliance.

Information!

Although these tests were carried out in standard laboratory conditions, the actual performance of the appliance might deviate from the values stated here.



Models 9000 077 095 and 9000 077 096 were tested by NSF International in accordance with ANSI/NSF Standard 53 and certified for cyst and cloudiness reduction. In addition, they were tested as per ANSI/NSF Standard 42 and certified for the reduction of chlorine taste and smell.

Rated particle class: I

Rated service life: 2800 litres

Substance	Average load in supply water	Permitted concentration as per NSF	Average reduction in %	Average concentration in water
Cysts *	122,500 cysts/l	Min. 50,000 cysts/l	99.99	< 1 cyst/l
Turbidity	10.8 NTU	11 ± 1 NTU	98.8	< 0.16 NTU
Rated value for particle class I ≥ 0.5 to < 1 µm	13,666,666pts/ml	Min. 10,000 particles/ml	99.00	143,333pts/ml
Chlorine taste and smell	2.0 mg/l	2.0 mg/l ± 10 %	97.5	< 0.05 mg/l

Substance	Max. permitted concentration in wastewater	Required reduction as per NSF	NSF test report
Cysts *	N/A	≥ 99.95 %	J-00056513
Turbidity	0.5 NTU	95.5 %	J-00058972
Rated value for particle class I ≥ 0.5 to < 1 µm	N/A	≥ 85 %	J-00056506
Chlorine taste and smell	N/A	≥ 50 %	J-00056501

* Based on the use of *Cryptosporium parvum* oocysts.

Guidelines for use/water supply parameters:

Water pressure	207 – 827 kPa
Water temperature	0.6 °C – 38 °C
Flow velocity	0.75 gpm (2.83 lpm)

- The system must be installed and operated in accordance with the manufacturer's guidelines.
- The filter must be replaced every 6 months.
- Flush new filters for 5 minutes.
- For more details, see the guarantee card.

Without adequate disinfection before or after connection to the system, this product should NOT be used if the water has harmful microbiologic qualities or if its quality is unknown. A system certified for cyst reduction may be used for disinfected water that contains cysts that can be filtered out, among other things.

The entire system (apart from the cartridge) is subject to a one-year warranty. In the case of the cartridges, the warranty only covers material/processing defects. The service life of the cartridges depends on the local water properties, so no guarantee of service life is given.

For more information on the price of spare parts, contact your local appliance dealer or parts agent.

Manufactured by:

Cuno Engineered Products
1000 Apollo Road
Eagan, MN 55121-2240 U.S.A

Saving energy

- Install the appliance in a dry room that can be ventilated; not in direct sunlight or in the proximity of a heat source (e.g. radiator, cooker). If necessary, use an insulating plate.
- Allow warm food and beverages to cool before putting them into the appliance.
- Put frozen foods that are to be thawed out into the fridge. This means that you will then use the coldness of the frozen foods to chill the other food in the fridge compartment.
- Open the appliance doors for as short a period as possible.

Operating noises

Completely normal noises

Humming - cooling unit is running, air circulation fan is running.

Bubbling, whirring, or gurgling noises - refrigerant is flowing through the pipes, water is flowing into the ice maker.

Clicking - motor is switching on or off, solenoid valve on water connection is opening or closing.

Rumbling - finished ice cubes from the ice maker are falling into the ice cube container.

Preventing noises

If the appliance is positioned unevenly

Use a spirit level to align the appliance so that it is level. This can be achieved by using the threaded feet or by placing something beneath it.

If the appliance is touching adjacent units or appliances

Move the appliance away from adjoining furniture or appliances.

If drawers, baskets or storage surfaces are loose or sticking

Check the parts that can be removed and reposition them if necessary.

If containers are touching

Move the bottles or containers apart slightly.

Defrosting

Freezer compartment

Thanks to the fully automatic no-frost system, the freezer compartment remains ice-free. There is no need to defrost it.

Fridge compartment

The defrosting is performed automatically.

The condensation flows through the drainage hole to an evaporation tray on the rear of the appliance.

Switching the appliance off and placing it out of operation

Switching off the appliance

Pull out mains plug or switch off circuit breaker.

Disconnecting the appliance

If you do not use the appliance for long periods:

1. You must interrupt the water supply to the appliance several hours before switching it off.
2. Remove all food from the appliance.
3. Pull out the mains plug.
4. Remove the filter cartridge and throw it away.
5. Empty and clean the ice cube container.
6. Clean the inside of the appliance (see section "Cleaning the appliance").

To prevent smells, leave the appliance doors open.

Cleaning

⚠ Warning!

Risk of electric shock!

Prior to cleaning, unplug the appliance or disconnect the fuse.

Caution!

Risk of damage to property and risk of minor injuries.

- Never clean the appliance with a steam cleaning device!
- Do not use sandy or acidic cleaning agents or solvents.
- Wipe down the lights and control/display panel with a damp cloth. No rinse water may enter the lights or the control/display panel.
- No rinse water may enter the drainage hole in the evaporation area.
- Never clean the shelves or containers in the dishwasher. Doing so can cause the parts to deform.

Cleaning the appliance

The HydroFresh drawers and the delicatessen drawer can be removed for cleaning.

1. Pull out mains plug or switch off circuit breaker.
2. Remove all food from the appliance and store in a cool place.
3. Clean the appliance with a soft cloth, lukewarm water, and a little pH-neutral detergent.
4. Dry the appliance with a cloth.
5. Wipe down the door seal with clean water only and thoroughly rub dry afterwards.
6. After cleaning, switch the appliance on.

Cleaning the water collection tray

Spilled water collects in the collection tray.

Remove the sieve to empty and clean it. Wipe out the water collection tray with a sponge or absorbent cloth.

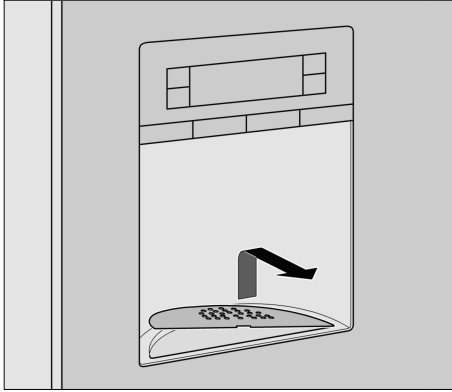

Cleaning the ice cube container

If no ice cubes have been removed for an extended period of time, the ice cubes that have already been made shrink, taste stale and stick together.

Caution!

Risk of injury.

A full ice cube container is heavy. Remove the ice cube container very carefully.

1. Press the release button and remove the ice cube container.

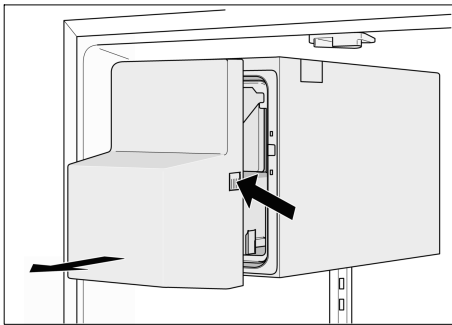

2. Empty the ice cube container and clean with lukewarm water.

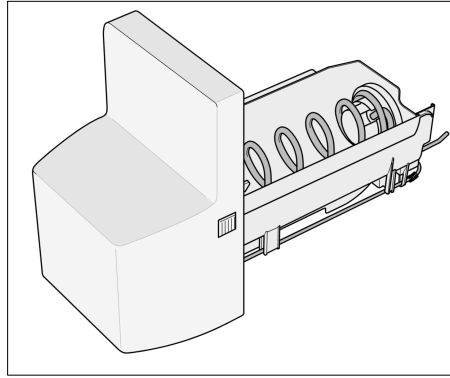

3. Rub the ice cube container and feed screw until they are completely dry, so that the new ice cubes do not freeze to them.

Inserting the ice cube container

4. Push the ice cube container right back on the supports until it snaps into place.

Information!

If you cannot push the container right the way back, turn the feed screw a little in the container or remove any frozen-on ice cubes from the loading area.

Removing the special moisture filter

1. Pull the HydroFresh drawers about 10 cm out.
2. Flip up the glass plate above the HydroFresh drawers and remove it.

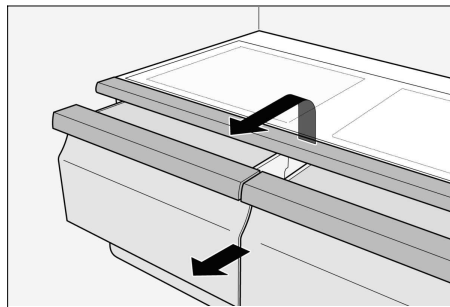

3. Reach between the cover openings, carefully unhook the front 4 catches, and remove the cover.

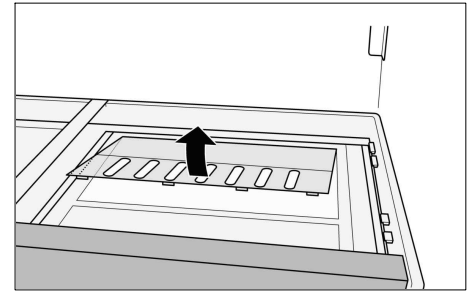

4. Remove the special moisture filter.

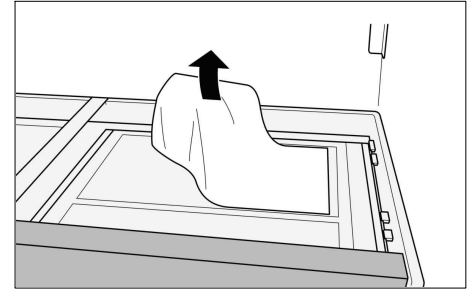

5. Clean the special moisture filter in lukewarm water and allow to dry.
6. Insert the special moisture filter.
7. Hook in the cover at the rear, fold down, and snap into place at the front.
8. Insert the glass plate and close the HydroFresh drawers.

Lighting (LED)

Your device is equipped with a maintenance-free LED light.

Caution!

Risk of eye injuries due to Class 1M laser radiation (IEC 60825)!

Do not look straight at the light using optical instruments.

Any repair work on the lighting may only be carried out by customer services or authorised experts.

Repairing minor malfunctions yourself

Before you call customer service:

Check whether you can solve the problem yourself on the basis of the following information.

You must bear the costs for consultation with customer services yourself - even during the warranty period.

Fridge and freezer compartment

Malfunction	Possible cause	Remedial action
No display on display panel, inside light does not work, appliance is not working.	The mains plug is not plugged in.	Plug the power cord into the mains.
	The domestic connection fuse has tripped.	Replace or switch on the fuse. Check whether there is power.
	Power failure.	Wait until the power is again restored. If necessary, inform installer or the electrical supply company.
The inside light is not working.	The light switch for the fridge or freezer compartment is jammed.	See whether you can move the light switch.
	The LED lighting is faulty.	See section "Lighting (LED)".
The food is too cold.	The temperature is set too low.	Turn the temperature up.
Food is too warm.	The door won't close properly.	Align the appliance using a spirit level. See section "Aligning the appliance". Check the position of the drawers and correct their position if necessary. Check the door seals and door strut; if necessary, clean them or correct their position.
	The temperature is set too high.	Lower the temperature.
	The ventilation opening is blocked.	Move food away from the ventilation opening.
	The doors were opened several times or were left open for a relatively long time.	Wait until the temperature inside the appliance has dropped.
	Large quantities of fresh food were added to the appliance.	Fresh food must first reach the proper storage temperature.
	Food that has a strong odour was placed into it.	Wrap the food in question or place into odour-tight containers.
	The inside of the appliance is dirty.	Clean the inside of the appliance.
Water drops form outside on the appliance.	The door won't close properly.	Align the appliance using a spirit level. See section "Aligning the appliance". Check the position of the drawers and correct their position if necessary. Check the door seals and door strut; if necessary, clean them or correct their position.
	The air humidity is too high.	In certain cases, this can be normal.
	The air humidity is too high or the doors were opened too frequently.	Do not open the doors as often and do not leave them open for relatively long periods.
Water drops form in the appliance.	The door seals are not leak-tight.	Check the door seals and door strut; if necessary, clean them or correct their position.
	The drawer is inserted incorrectly.	Insert the drawer correctly.
Drawers can be closed only with difficulty.	The drawer rails are dirty.	Clean the drawer rails.

Ice and water dispenser

Malfunction	Possible cause	Remedial action
The water filter symbol is flashing.	The filter cartridge is worn out.	Replace the filter cartridge.
	Following the replacement of the filter cartridge, the water filter symbol was not reset.	Reset the water filter symbol.
The ice maker is not producing enough ice cubes or the ice cubes are a strange shape.	The appliance or ice maker was only switched on a short time ago.	It takes approx. 24 hours before ice production begins.
	A large amount of ice was removed.	It takes approx. 24 hours, until the ice cube container is again filled.
	Water pressure too low.	Check the water pressure.
	The filter cartridge is blocked or worn out.	Replace the filter cartridge.
The ice maker is not producing enough ice cubes or isn't producing any at all.	An ice cube has become stuck in the arm used to measure the fill level of the ice cube container.	Pull out the ice cube container and remove the stuck ice using a blunt plastic implement. Do not use pointed or sharp objects, as this could damage the appliance.
	When switching from ice cubes to crushed ice, an ice cube might get stuck in the dispenser opening. The ice cube drips into the ice and water dispenser.	Remove the stuck ice from the dispenser opening using a blunt plastic implement. Do not use pointed or sharp objects, as this could damage the appliance.
	There is a layer of ice on the feed screw.	Pull out the ice cube container and clean it.
The ice cube container contains ice cubes but they are not being dispensed.	The ice cubes have frozen together.	Pull out the ice cube container and clean it.
The ice maker is not producing ice cubes.	The ice maker is switched off.	Switch the ice maker on.
	The appliance is not being supplied with water.	Have a skilled plumber check the water connection line.
	There are kinks in the water connection line.	Turn off the water supply. Smooth out the kinks. Have the damaged water connection line replaced by an original spare part from the manufacturer.
	Water pressure too low.	Check the water pressure.
	The ice cube container is not inserted properly.	Insert the ice cube container properly.
	The water connection is improperly installed.	An improper water connection can cause low water pressure and damage to the appliance.

Malfunction	Possible cause	Remedial action
No water or only a small amount of water is dispensed by the water dispenser.	The filter cartridge is blocked or worn out.	Replace the filter cartridge.
	Water pressure too low.	Check the water pressure.
	The stop valve is not completely open.	Open the stop valve and make sure that it remains open.
	There are kinks in the water connection line.	Turn off the water supply. Smooth out the kinks. Have the damaged water connection line replaced by an original spare part from the manufacturer.
The dispensed water is not cold.	The appliance was only recently set up.	The water requires approx. 12 hours to be chilled down.
	Water has stood for an extended period of time in the lines and has adjusted to the ambient temperature.	Fill and discard 15 glasses of water.
The water is cloudy.	Air or bubbles in the water.	Normal during first use of the water dispenser. Disappears after a short period of time.
There are suspended particles in the water or in the ice cubes.	The water that first flows through the filter cartridge can dislodge carbon dust from the filter cartridge.	Suspended particles are not harmful! After a short time, these suspended particles will disappear.
	If water freezes and thaws out again, suspended particles are formed through mineral deposits.	Suspended particles are not harmful! They are a natural feature of the water supply.

Customer services

You can find a nearby customer services branch in the telephone directory or in the customer services listing. Please inform customer services of the product number (E no.) and manufacturing number (FD no.) of the appliance.

You will find this information on the nameplate.

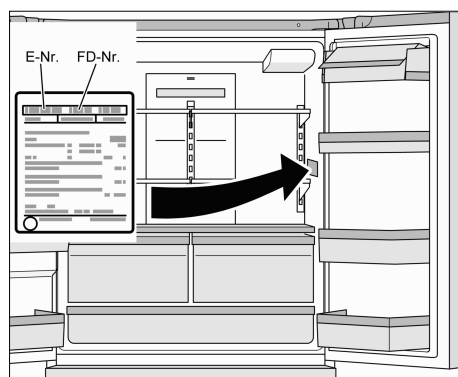

Please help in avoiding unnecessary service calls by providing the product and manufacturing number. You will save the extra associated costs.

