



Armoire à vin.

Wine Preservation Technology

USER MANUAL

**V110SG”e”-ss
V110SG”2e”-ss**

**V155SG”e”-ss
V155SG”2e”-ss**



applied

Australia

online
.com.au

Appliance retailer

WARNING

The information in this document is subject to modification without any prior notice.

VINTEC offers no guarantee for our wine cellar if it is being used for any purpose other than that for which it was specifically designed. VINTEC cannot be held responsible for any error in this manual. VINTEC is not responsible or liable for any spoilage or damage to wines or any other contents incidental or consequential to possible defects of the wine cellar. Warranty applies to the wine cellar only and not to the contents of the wine cellar.

This appliance is not intended for use by persons (including children) with reduced physical, sensory or mental capabilities, or lack of experience and knowledge, unless they have been given supervision or instruction concerning use of the appliance by a person responsible for their safety.

Children should be supervised to ensure that they do not play with the appliance.

Allow 24 hours before switching on the wine cellar. During this time we recommend that you leave the door open to clear any residual odors.

BEFORE LOADING & PLUGGING IN THE WINE CELLAR

Important: All models without front venting (air opening) are strictly for free standing only. (see technical chart)

Recommendations:

The location you have selected for your wine cellar should:

- be unencumbered and well ventilated;
- be well away from any heat source and direct sunlight;
- not be too damp (laundry, pantry, bathroom etc.);
- have a flat floor,
- have a standard and reliable electricity supply (standard socket to country standards, linked to the ground), it is NOT recommended to use a multi-socket or extension lead.
- have a surge protector fitted to the electrical outlet
- away from microwave. Certain microwave ovens do not have wave interference shield. When placed within 1 meter vicinity of the wine cabinet, they may affect the operation of the wine cabinet.

The wine cellar should be placed where the ambient temperature is between 5°C to 43°C. If the ambient temperature is above or below this range, the performance of the unit may be affected. Placing your unit in extreme cold or hot conditions may cause interior temperatures to fluctuate. The ideal range of temperature may not be reached. (See Climate Class at the end of this manual)

Grounding instructions

The wine cellar must be grounded in case of an electrical short circuit. Grounding reduces the risk of electrical shock. The wine cellar is equipped with a power cord having a grounding wire and grounding plug. The wine cellar plug must be plugged into a properly installed and grounded electrical outlet.

Note : *In locations where there is frequent lightning, it is advisable to use surge protectors.*

Improper use of the grounding plug can result in the risk of electric shock. Consult a qualified electrician or service person if the grounding instructions are not completely understood.

If the supply cord is damaged, it must be replaced by a qualified person in order to avoid electrical hazard.

Installing your wine cellar

Unpack and remove all of the protection and adhesive strips from the packaging around and inside the wine cellar.

The wine cellar must be positioned such that the plug is accessible. Release the power cord. Move your wine cellar to its final location. The wine cellar should be installed in a suitable place where the compressor will not be subject to physical contact.

Leveling your wine cellar: *Wine cellar must be leveled BEFORE loading your wines.*

Your wine cellar is equipped with 4 adjustable feet to facilitate easy leveling. VINTEC recommends that you tighten the back feet to the maximum and adjust the front feet to create a level.

Back spacer:

Compressor-run appliances require proper ventilation for proper and longer usage. Your Vintec wine cellar is supplied with a back spacer. Affix the back spacer at the back of the cellar for air circulation and heat evacuation.

INSTALLATION OF BACK SPACER

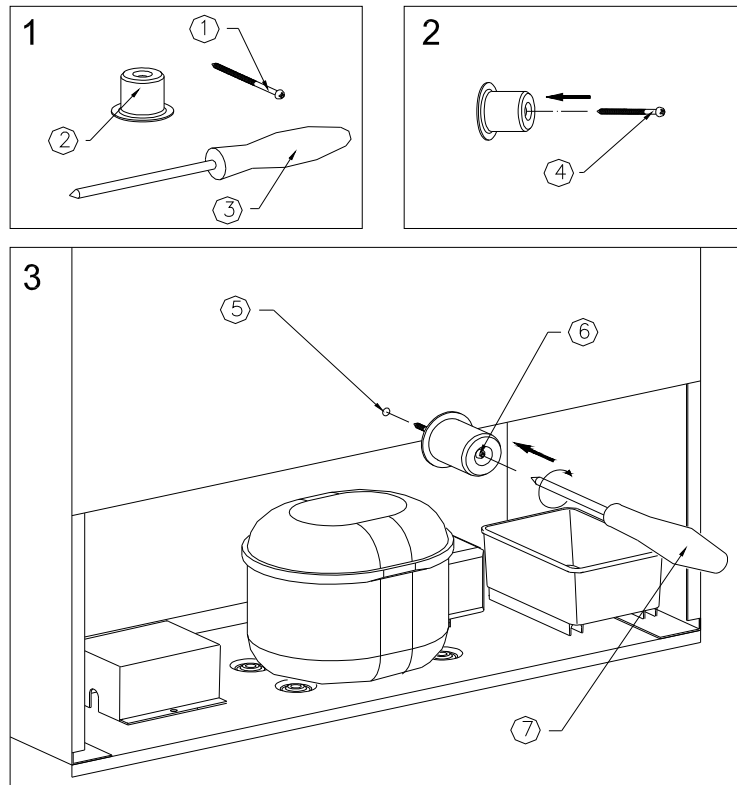

IMPORTANT - THIS SPACER MUST BE ATTACHED TO THE UNIT BEFORE INSTALLATION FOR VENTILATION PURPOSE. FAILURE TO DO SO VOIDS THE WARRANTY

TURNING ON YOUR WINE CELLAR

Plug in and switch on the cellar by pressing on the power button for a few seconds.

When you use the wine cellar for the first time (or restart the wine cellar after having it power off for a long time), there will be a few degrees variance between the temperature you have selected and the one indicated on the LED readout. This is normal and it is due to the length of the activation time. Once the wine cellar is running for a few hours everything will stabilize.

Important: If the unit is unplugged, power is lost, or turned off, wait 3 to 5 minutes before restarting the unit. The wine cellar will not start if you attempt to restart before this time delay.

Operating Noises

To reach the desired temperature settings, VINTEC wine cellars, like all wine cellars operating with compressors and fans, may produce the following types of noises. These noises are normal and occur as follows:

- Gurgling sound, caused by the refrigerant flowing through the appliance's coils,
- Cracking/popping sounds, resulting from the contraction and expansion of the refrigerant gas to produce cold,
- Fan operating sound, to circulate the air within the wine cellar.

An individual's perception of noise is directly linked to the environment in which the wine cellar is located, as well the specific type of models. VINTEC wine cellars are in line with international standards for such appliance. VINTEC will always do its utmost to satisfy its customers but will not retake possession of the goods due to complaints based on normal operating noise occurrences.

LOADING YOUR WINE CELLAR

You may load your wine bottles in single or double rows while taking note of the following: if you do not have enough bottles to fill your wine cellar, it is better to distribute the load throughout the wine cellar so as to avoid "all on top" or "all below" type loads.

- Do not remove or relocate adjustable wooden shelves to accommodate larger type of bottles or increase the capacity of the cellar by stacking the bottles up when necessary. (See removing shelves)
- Keep small gaps between the wall and the bottles to allow air circulation. Like an underground cellar air circulation is important to prevent mould and for a better homogeneous temperature within the cellar.



- Do not over load your wine cellar to facilitate air circulation.
- Do not stack more than 1.5 rows of standard 0.75L bottles per shelves to facilitate air circulation
- Avoid obstructing the internal fans (located inside on the back panel of the wine cellar).
- Do not try to slide the shelves outwards beyond the fixed position to prevent the bottles from falling.

- Do not pull out more than one loaded shelf at a time as this may cause the wine cellar to tilt forward.
- Do not cover the wooden shelves with alloy foil or other materials, as it will obstruct air circulation.
- Do not move your wine cellar while it is loaded with wines. This might distort the body of the wine cellar and cause back injury.

TYPES OF REGULATION

Please note that depending on the loading and settings chosen it takes 24hours for the wine cellar to see the temperature stabilizing.

During this time LED seems to move erratically in particular for 2e models. It is a normal process. This process occurs whenever the setting is modified and/or whenever a large amount of bottles are added to the cellar.

Single Temperature Maturing/Storage Wine Cellars:

- **“e” series : electronic regulation, digital display**

Designed to store and mature all wines: red, white and sparkling. These wine cellars reproduce the ideal conditions for **wine storage**, at a constant recommended temperature of 12°C to 14°C. They can also be set to provide ideal serving temperature for full enjoyment of the wine’s qualities. Unless stated by the wine maker on the bottle, **VINTEC** recommends 7°C for your champagne, 12°C for whites and 18°C for reds. (Refer to “Wine Service Temperature” recommendation chart)

Two-Temperature Serving Wine Cellars (2-in-1 Wine Cellars):

- **“2e” series: electronic regulation digital display**

Made of two independent compartments regulated independently as 2 single zone wine cellars. Like the e models, each compartment are adjustable from 5°C to 18°C. Ideal for storage or “mise en temperature” (The right temperature for optimum enjoyment)

TEMPERATURE SETTINGS

Important: The LCD displays by default the actual internal air temperature.

The temperature settings are pre-set at the factory as follows. In the event of a power interruption, all previous temperature settings are automatically erased and it will revert to the preset temperature settings.

Factory preset chart

e models: 12°C

2e models: 7°C for the upper compartment and 12°C for the lower compartment.

It is important to understand that there is a difference between the air temperature inside the wine cellar and the actual temperature of the wine: You will need to wait approximately 12 hours before noticing the effects of temperature adjustment due to the critical mass within a full wine cellar.

Once the thermostat is set it is strongly advised not to toy with it or adjust frequently. The thermostat will maintain the temperature inside the wine cellar within a +/- 2.5°C range. But the thermal inertia of the wine and the glass is such that within this temperature range, the actual temperature of the wine will only fluctuate 0.5°C to 1°C.

e models:

The TEMP. SET . LCD displays the set temperature

The DISPLAY LCD displays the internal air temperature

Control panel of e model wine cellars

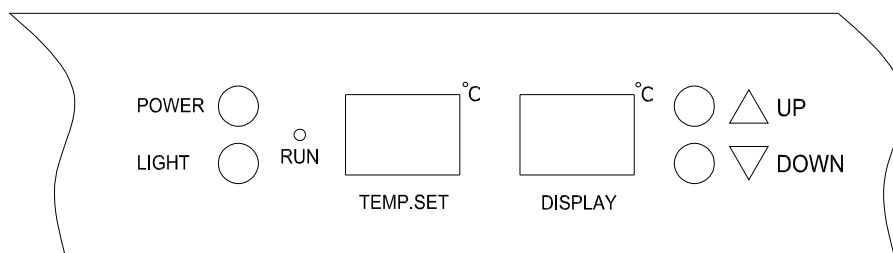

To modify the pre-set temperature of e models

Adjust the desired cooling temperature by pressing the UP or DOWN buttons. Each depression of the buttons will scroll through the available temperature settings in increments of 1 degree Celsius. The temperature setting can be adjusted from 5□ to 18□ .

2e models:

The “DISPLAY LED” displays the internal air temperature. The set temperature automatically appears by pressing either the UP or DOWN button

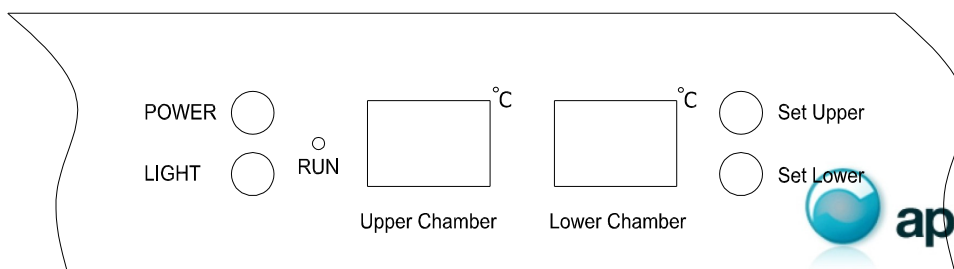

To modify the pre-set temperature of 2e models

Adjust the desired cooling temperature by pressing the UP or DOWN buttons. Each depression of the buttons will scroll through the available temperature settings in increments of 1 degree Celsius. The temperature setting can be adjusted from 5°C to 18°C

To visualize the “set” temperature, press and hold the UP or DOWN buttons, the “set” temperature will temporarily “flash” in the LED display for 5 seconds.

WINE SERVING TEMPERATURE CHART

All wines mature at the same temperature, which is a constant temperature set between 12°C to 14°C. The below chart is an indicative temperature chart to indicate the best temperature for drinking purposes.

Champagne NV, Sparkling, Spumante	6°C
Dry White Semillon, Sauvignon Blanc	8°C
Champagne Vintage,	10°C
Dry White Chardonnay	10°C
Dry White Gewürztraminer, Riesling, Pinot grigio	10°C
Sweet White Sauternes, Montbazillac, Ice Wine, Late Harvest	10°C
Beaujolais	13°C
Sweet White Vintage Sauternes	14°C
White Vintage Chardonnay	14°C
Red Pinot Noir,	16°C
Red Grenache, Syrah	16°C
Red Vintage Pinot Noir	18°C
Cabernet & Merlot: French, Australian, New Zealand, Chilean, Italian, Spanish, Californian, Argentinean...	20°C
Vintage Bordeaux ...	Room temperature not exceeding 20°C

IMPORTANT INFORMATION ABOUT TEMPERATURE

Your VINTEC wine cellar has been designed to guarantee optimum conditions for storing and/or serving your wines.

Fine wines require long and gentle developments and need specific conditions in which to reach their full potential.

All wines mature at the same temperature, which is a constant temperature set between 12°C to 14°C. Only the temperature of “dégustation” (wine appreciation) varies according to the type of wines (see “Wine Serving Temperature Chart” above). This being said and as it is for natural cellars used by wine producers for long period of storage, it is not the exact temperature that is important, but its consistency. In other words, as long as the temperature of your wine cellar is constant (between 12°C to 14°C) your wines will be stored in perfect conditions.

Not all wines will improve over the years. Some should be consumed at an early stage (2 to 3 years) while others have tremendous ageing capability (50 and over). All wines have a peak in maturity. Do check with your wine merchant to get the relevant information.

DEFROSTING/CONDENSATION/ HYGROMETRY/ VENTILATION

Your wine cellar is designed with “Auto-cycle” defrost system. During “Off-cycle” the refrigerated surfaces of the wine cellar defrost automatically. Defrost water from the wine cellar storage compartment drains automatically and part of it goes into a drainage container, which is located at the back of the wine cellar next to the compressor. The heat is transferred from the compressor and evaporates any condensation that has collected in the pan. Part of the remaining water is collected within the wine cellar for humidity purposes.

This system enables the creation of the correct humidity level inside your wine cellar required by the natural cork to maintain a long lasting seal.

Notes: *The water collected by condensation, is therefore recycled. Under extremely dry environmental conditions, you may have to add some water into the water container provided with your wine cellar.*

All units are equipped with a double glazed glass door that has a third internal acrylic layer to minimize condensation on the glass door.

The wine cellar is not totally sealed; fresh air admission is permitted through the drainpipe. Air is circulated through the cellar by means of a fan/fans and the hollow shelves.

Notes: *During the refrigerating cycle, heat is given off and disperse through the external surfaces of the wine cellar. Avoid touching the surfaces during those cycles.*

SLIDING SHELVES

To prevent damaging the door gasket, make sure to have the door opened all the way when pulling the shelves.

For easy access to the bottles, you must pull the shelves approximately 1/3 of its depth out of the rail compartment. These wine cabinets, however, are designed with a notch on each side of the shelf tracks to prevent bottles from falling.

To remove the shelf :

-align the shelf gap (left and right) under the square plastic block, lift up and tilt the shelf .

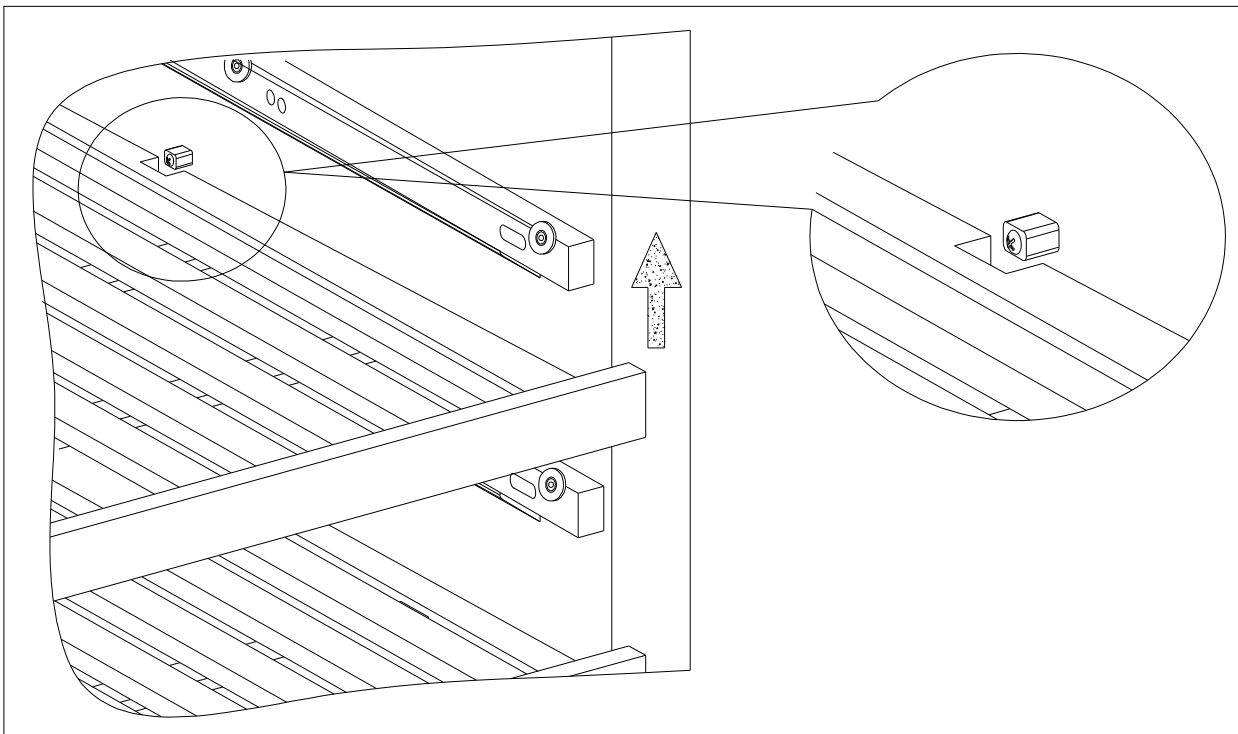

Drawings for built-in purposes
V110SG "e" & "2e"

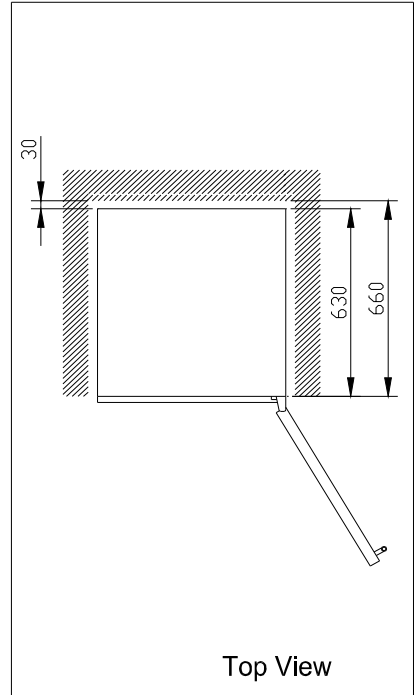
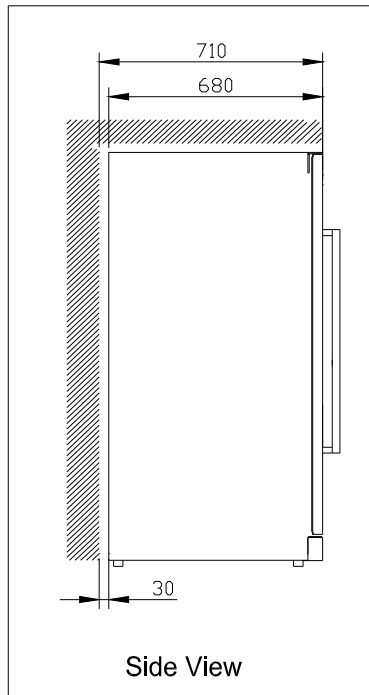
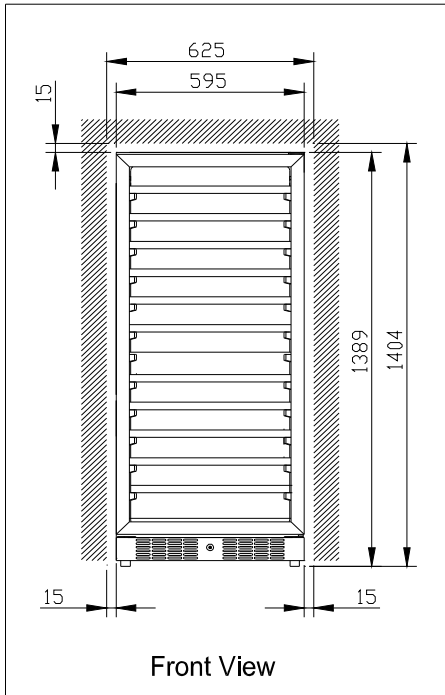

V155SG "e" & "2e"

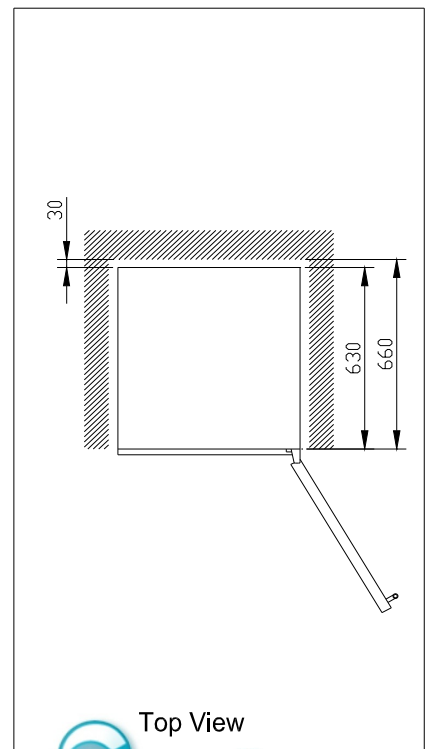
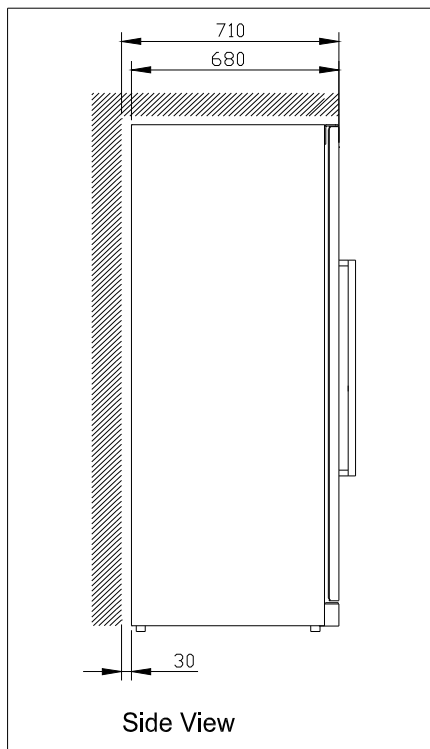
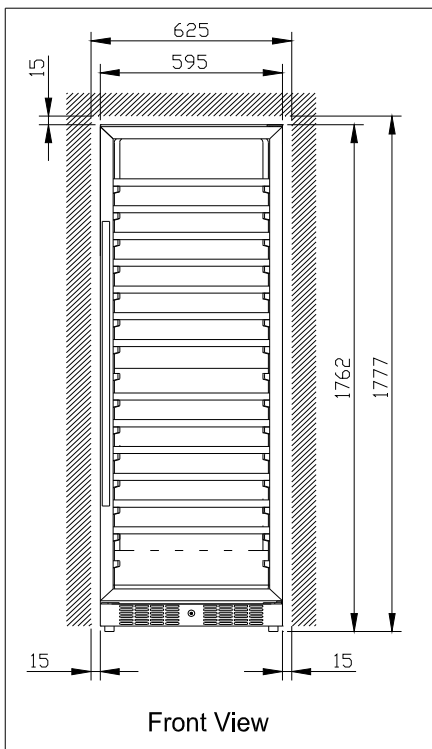

OPERATION ANOMALIES

Ensure that there is power to the electrical supply plug by connecting another electrical appliance to it. Check fuse, if any. Make sure that the door is closed properly.

If your wine cellar appears to be malfunctioning, unplug it and contact your VINTEC's after sales service. Any intervention on the cold circuit should be performed by a refrigeration technician who should carry out an inspection of the circuit sealing system. Similarly, any intervention on the electrical circuit should be performed by a qualified electrician.

Notes : *Any intervention performed by a non-technician will lead to the warranty being considered as null and void.*

POWER FAILURES

In the event of a power interruption, all previous temperature settings are automatically erased and it will revert to a preset temperature setting . (see preset chart)

Most power failures are corrected within a short period of time. An hour or two's loss of power will not affect your wine cellar's temperatures. To avoid sudden change of temperature while the power is off, you should avoid opening the door. For longer period of power failure, do take steps to protect your wine.

Irrespective of the cause, if you notice either abnormal temperature or humidity levels inside your wine cellar, be reassured that only long and frequent exposure to these abnormal conditions can cause a detrimental effect on your wines.

TROUBLESHOOTING GUIDE

Common problems may easily be solved, saving you the cost of a possible service call. Please read carefully the instruction manual and revert to troubleshooting guide chart.

PROBLEM	POSSIBLE CAUSE
Wine cellar does not operate.	Not plugged in. The appliance is turned off. The circuit breaker tripped or a blown fuse.
Wine cellar is not cold enough.	Check the temperature control setting. External environment may require a higher setting. The door is opened too often. The door is not closed completely. The door gasket does not seal properly.
Turns on and off frequently.	The room temperature is hotter than normal. A large amount of contents has been added to the Wine cellar. The door is opened too often. The door is not closed completely. The temperature control is not set correctly. The door gasket does not seal properly.
The light does not work.	Not plugged in. The circuit breaker tripped or a blown fuse. The bulb has burned out. The light button is "OFF".
Vibrations.	Check to assure that the Wine cellar is level.
The Wine cellar seems to make too much noise.	The rattling noise may come from the flow of the refrigerant, which is normal. As each cycle ends, you may hear gurgling sounds caused by the flow of refrigerant in your Wine cellar. Contraction and expansion of the inside walls may cause popping and crackling noises. The Wine cellar is not level.
The door will not close properly.	The Wine cellar is not level. The door was reversed and not properly installed. The gasket is faulty. (magnet or rubber is spoiled) The shelves are out of position.

Product specification Chart

Technical data	V110SG"e"	V110SG"2e"	V155SG"e'	V155SG"2e"
Capacity750ml (Std. Bordeaux type bottle)	111	Upper 50 Lower 51	151	Upper 70 Lower 71
Net capacity	317 L	308 L	421 L	412 L
Pre-set temp in degrees	12	Upper 7 Lower 12	12	Upper 7 Lower 12
Adjustable temp in degrees	5 -18	Upper 5 -18 Lower 5-18	5 -18	Upper 5 -18 Lower 5 -18
Power Input	180 W	180 W	185 W	185W
Heater	Yes	Yes	Yes	Yes
Freestanding or Built-in	Both	Both	Both	Both
No.of wooden shelf	11 (10 +base)	10 (9 + base)	15 (14 + base)	14 (13 + base)
Ambient temp in degrees	5-43	5-43	5-43	5-43
Climate Class	T	T	T	T
Net dim in mm WDXH	595X680X1389	595X680x1389	595X680X1762	595X680X1762
Gross dim in mm WDXH*	650X750X1445	650X750X1445	650X750X1820	650X750X1820
Net weight	86kg	87kg	105kg	106kg
Gross weight	98kg	99kg	118kg	119kg

Standard features:

Compressor operated: R134a

- Available in rated voltage/frequency (as per country's requirements): 100V/50/60Hz, 220V/50/60Hz, 115V/50Hz

- Automatic defrost

- Antifreeze device

- Humidity : 65% RH +/-10% RH

- Adjustable wooden shelves on wheels

- Black outer and inner finish

- Internal light LED

- Adjustable feet x 4

- Double glass door with 3rd acrylic layer

- Glass door opening stainless steel finish on option ref "ss"

*Based on carton box packing dimensions/weight



Copyright: All rights are reserved. All photocopying, reproduction, translation whether partial or total are strictly prohibited, without prior written consent from VINTEC.

www.vintec-cellar.com

