

FAMILIES COME IN ALL SHAPES AND SIZES. JUST LIKE OUR FRIDGES.



FRIDGES FLEXIBLE ENOUGH FOR ANY FAMILY

side by side, bottom mount, top mount, single door refrigeration
& vertical freezers



Westinghouse

A SEAMLESSLY CO-ORDINATED KITCHEN RANGE

Westinghouse kitchens are designed with your whole family in mind. Because we know when it comes to families, you require kitchen appliances that are practical and reliable. From a quick meal to a full roast, with Westinghouse you have a seamlessly coordinated range of appliances. Flexible fridges and large capacity ovens ensure you can cater for any occasion. Whilst easy loading, water conservative dishwashers mean you can kick back and enjoy your guest's company. So you will be pleased to know our new range of appliances work with your kitchen as well as they work with you.



Westinghouse refrigerators have started converting over to the less harmful R600a refrigerant. That means every day, the family refrigerator can quietly play its own part in reducing the household's impact on the environment. Look out for this symbol, as well as, R600a in the specification tables, to see which models have already changed over.

FLEXIBLE ENOUGH FOR ANY FAMILY

Isn't it amazing how quickly your family grows? It seems like one minute it's baby bottles and the next it's school lunches. That's why Westinghouse has introduced a truly family friendly range of fridges, with interiors that are so flexible they can easily be adjusted to suit your family's changing needs.

We're proud to be Australia's favourite refrigeration brand[^], and to offer you the widest range of refrigeration solutions[‡] for your home. Having witnessed the needs of Australian families evolve over the past 68 years, all of our fridges have been designed with interiors that are flexible enough to cater for food of all shapes and sizes!

Westinghouse offers Australia's most extensive range of fridges and freezers, so take a closer look at the vast range of practical features, from Australia's most trusted whitegoods brand[°]:

FEATURE*	MEANING...	BENEFIT TO YOU
Adjustable Interiors	Over 20 different shelving and door bin positions, giving you hundreds of possible shelf combinations	It's easy to make everything fit perfectly, from the smallest deli items to the largest party platters
Specialised compartments	Drawers and crispers on telescopic extension slides Differently humidified compartments for fruit and vegetables Twist ice and serve Lockable storesafe™ drawers	Drawers glide out smoothly, no matter how full Keeps fruit and vegetables fresher for longer Easy access to more ice, more often Keeps medicines safely away from inquisitive little fingers
Electronic controls	Displays average fridge temperature and allows adjustments in 1°C increments 'Quick freeze' boosts freezer to max setting for 90 mins at the touch of a button Alarms sound when the fridge door is left open or the drinks chill timer finishes	Takes the guesswork out of setting your fridge and freezer temperatures Rapidly freezes items to lock in flavours and nutrients Helps prevent accidental food spoilage

*Features vary by model

[^] Source: GfK sales volume data year ending Jul 2009, 2008, 2007, 2006, 2005, 2004, 2003, 2002 and 2001

[‡] Source: GfK sales volume data 2008, 2007



[°]Readers Digest survey 2009, 2005



Model shown: WBE5100SB bottom mount fridge

A GUIDE TO BUYING YOUR NEXT FRIDGE

After your house and car, a fridge is one of the more expensive purchases you will make. That's why it's essential you make the right choice. But there are so many different types of fridges out there that it can be overwhelming. That's where Westinghouse can help. In the table below are some guidelines and questions to help you decide on the right fridge for your family.

TYPE/STYLE	<p>Would white, pacific silver or stainless steel suit your kitchen?</p> <p>Do you have limited space and want all the benefits of a large fridge in a smaller model?</p> <p>Do you like the aesthetics of a side by side and the idea of an ice and water dispenser?</p> <p>Do you tend to have a lot of frozen food or do you need more fresh food and drink storage?</p>
DIMENSIONS	<p>Does it need to fit into an existing space? (And remember that fridges need a few centimetres of air space around them to keep them running at their best). Always measure your kitchen cavity and doorways before you choose a fridge.</p>
CAPACITY	<p>As a general rule, a family of two needs around 300L of food storage space. For each additional family member add around 30L. But keep in mind that your family may expand, so when in doubt, go larger. (Larger fridges tend to have more features and be more efficient).</p>
VALUE	<p>Consider which features are really useful to you, but keep in mind that your family's needs may change, so think ahead, or buy a fridge that will adapt to your changes.</p> <p>Ongoing running costs can eat into your family budget so check the energy rating system (the more stars and the lower kWh per year the better).</p>
EASY CLEANING	<p>Spillsafe™ shelves, easy-to-remove parts, and fingerprint-resistant surfaces can all make a big difference to your workload.</p>
FUNCTIONS & CONTROLS	<p>Manual controls are easy to use. Electronic controls offer a wider range of clever functions including drink chill and door alarms, quick freeze and holiday mode.</p>
SECURITY & RELIABILITY	<p>A fridge or freezer is a considerable investment. Today, there are many brands available of variable history and quality. It pays both financially and for peace-of-mind to ensure that the company that makes your fridge can provide advice, service and support for it well beyond the shop floor.</p>



Model shown: WTB2500PB

SIDE BY SIDES

SIDE BY SIDES[†]

Like having a full freezer and fridge in one unit? The new 700 litre side by side provides you with the maximum fresh food and freezer storage in one fridge – and with a fresh food section 508mm wide it is truly the fridge big enough for any family.

For those with big families but limited space the compact side by side is the perfect solution. Combining a full-length freezer on the left and a full-length fridge on the right, these models have been specifically designed to fit into the popular 600mm deep and 900mm wide fridge cavity – so you don't have to renovate your kitchen.



FILTERED ICE & WATER DISPENSER

Available on selected models, this dispenser delivers fresh, filtered water as well as cubed or crushed ice at the touch of a button.

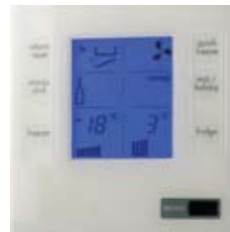

ELECTRONIC CONTROLS

Organising your fridge couldn't be easier! Separate temperature controls, fast chill for drinks and eco/holiday modes allow you to adjust your fridge to suit your lifestyle at the touch of a button.



EASY GLIDE DRAWERS & SPECIALISED COMPARTMENTS

Easy glide freezer bins and fridge crispers* give easy access without the effort – even when they're full. Humidity controlled crispers keep fruit and vegetables fresh, while deli drawers help isolate odours. Handy storesafe™ drawers put special items safely out of reach.



TWIST ICE & SERVE*

Twist ice and serve with ice caddy provides you with easy access to more ice, more often.



ADJUSTABLE INTERIORS WITH SPILLSAFE™ GLASS SHELVES

With over 20 different shelving and door bin positions, you can easily fit the smallest deli items to the biggest party platters. Spillsafe™ glass shelves improve visibility and isolate leaks – preventing up to 1 litre of spills from dripping down to the shelves below.



FINGERPRINT-RESISTANT STAINLESS STEEL DOORS

The innovative fingerprint-resistant stainless steel doors ensure all Westinghouse stainless steel fridges maintain that sleek fingerprint-free look. In fact, a damp cloth should be all you need to remove marks from any Westinghouse fridge or freezer.



BLUE FEATURE LIGHTING

Available on selected models, blue feature lighting increases visibility and enhances the stylish design of the fridge interior.



BOTTLE RACK

In selected models, the bottle rack offers a practical method of storing and organising all kinds of bottles – from soft drinks to wine and much more.

[†] Refer to the product information on the back page of this brochure

* Selected models



Model shown: WSE7000SA

- | | | |
|--|----------------------------|---|
| 1 Filtered ice & water dispenser (not shown) | 4 Adjustable interiors | 7 Spillsafe™ glass shelves |
| 2 Electronic controls (not shown) | 5 Specialised compartments | 8 Bottle rack |
| 3 Telescopic freezer bins and crispers | 6 Blue feature lighting | 9 500mm wide shelves – ideal for platters |

LARGE SIDE BY SIDE features†



Model shown: WSE6970SA



Model shown: WSE7000SA

model	WSE6970SA/WSE6970PA/ WSE6970WA	WSE7000SA/ WSE7000PA/ WSE7000WA
gross capacity (litres)	690	700
food compartment gross capacity (litres)	450	450
freezer compartment gross capacity (litres)	240	250
dimensions (and recommended clearances)	refer to page 26	refer to page 26
door finish	stainless steel/pacific silver/classic white	stainless steel/pacific silver/classic white
filtered ice and water dispenser (cubed & crushed ice)	✓	
electronic controls (door alarm, drinks chill timer, quick freeze function, holiday energy efficiency mode)	✓	✓
frost-free	✓	✓
separate temperature controls for fridge and freezer	✓	✓
fingerprint-resistant surface	✓	✓
fridge features		
easy glide crispers with humidity control	2	2
adjustable spillsafe™ glass shelves	3	3
repositional deli compartment (full-width)	✓	✓
dairy compartment (full-width)	✓	✓
bottle bin (full-width)/with bottle fingers	3/2	3/2
interior fridge light	✓	✓
freezer features		
easy glide freezer bins	2	2
adjustable spill safe slide-out glass shelves	2	3
adjustable freezer door bins (full-width) – clear	3	5
pizza shelf/drawer	✓/–	–/✓
twist ice and serve		3
interior freezer light	✓	✓
other features		
adjustable front rollers	✓	✓
rear rollers	✓	✓
energy star rating (new)	2	2
energy star rating (on old scale)	4	4
energy consumption (kwh/year)	729	699

† Refer to the product information on the back page of this brochure

COMPACT SIDE BY SIDE features†



Model shown: WSE6070SB



Model shown: WSE6100WA

model	WSE6070SB/WSE6070WB	WSE6100SA/WSE6100PA/ WSE6100WA
gross capacity (litres)	600	610
food compartment gross capacity (litres)	360	357
freezer compartment gross capacity (litres)	240	249
dimensions (and recommended clearances)	refer to page 26	refer to page 26
door finish	stainless steel/classic white	stainless steel/pacific silver/classic white
filtered ice and water dispenser (cubed & crushed ice)	✓	
electronic controls (door alarm, drinks chill timer, quick freeze function, holiday energy efficiency mode, time display)	✓	✓
frost-free	✓	✓
fingerprint-resistant surface	✓	✓
fridge features		
blue feature lighting	✓	
storesafe™ drawer with child latch	✓	✓
adjustable spillsafe™ slide-out glass shelves	3	3
bottle rack	✓	✓
repositional deli compartment (full-width)	✓	✓
humidity controlled crisper bins (full-width)	2	2
dairy compartment (full-width)	✓	✓
bottle bin (full-width)/with bottle fingers	4/2	4/2
egg tray	✓	✓
interior fridge light	✓	✓
freezer features		
adjustable spill safe slide-out glass shelves	3	4
freezer basket with clear fascia	2	2
adjustable freezer door bins (full-width) – clear	3	5
ice cream shelf	✓	
ice cube trays/ice cube storage bin	-/-	2 / ✓
interior freezer light	✓	✓
other features		
adjustable front rollers	✓	✓
rear rollers	✓	✓
energy star rating (new)	2	2
energy star rating (on old scale)	3.5	4
energy consumption (kwh/year)	680	687

† Refer to the product information on the back page of this brochure

BOTTOM MOUNTS

BOTTOM MOUNTS[†]

We understand that fresh food is important. So we created a bottom mount with the freezer located below the fridge to give you easy access to the section your family will use the most – the fresh food compartment.



INTERNAL ELECTRONIC CONTROLS

With easy-to-reach electronic functions* like Fast Freeze, Drink Chill Timer, Temperature Controls and Eco mode, your Westinghouse refrigerator can be quickly adjusted to suit you, your family and your lifestyle.



EASY GLIDE CRISPERS AND FREEZER BINS

Telescopic freezer bins and fridge crispers* give the whole family quick and easy access without the effort – even when they're full.



TWIST ICE AND SERVE*

Twist ice and serve is an easy way to dispense ice. The removable ice bucket and scoop makes serving simple. (selected models only)



CHILL STREAM®

A chill stream® air curtain is directed down the front of the fridge from the top compartment, keeping your drinks at the front perfectly cold without freezing items at the back.



FINGERPRINT-RESISTANT STAINLESS STEEL DOORS

The innovative fingerprint-resistant stainless steel* doors ensure all Westinghouse stainless steel fridges maintain that sleek fingerprint-free look. In fact, a damp cloth should be all you need to remove marks from any Westinghouse fridge or freezer.

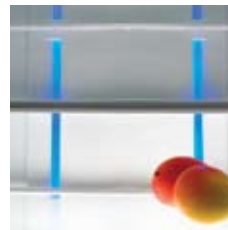

BLUE FEATURE LIGHTING

Available on selected models, blue feature lighting increases visibility and enhances the stylish design of the fridge interior.



ADJUSTABLE INTERIORS WITH SPILLSAFE™ GLASS SHELVES

With over 20 different shelving and door bin positions, you can easily fit the smallest deli items to the biggest party platters. Spillsafe™ glass shelves improve visibility and isolate leaks – preventing up to 1 litre of spills from dripping down to the shelves below.



INTEGRATED or BAR HANDLE

Selected models have bar handles whilst all others have integrated handles, giving you the choice of handle that suits your needs.

* Selected models only

† Refer to the product information on the back page of this brochure



Model shown: WBE5100SB

- 1** Adjustable interiors

2 Internal electronic controls

3 Chill stream®
- 4** Easy glide freezer bins and crispers

5 Twist ice and serve and portable ice bucket with scoop
- 6** Blue feature lighting

7 Spillsafe™ glass shelves

8 Bottle rack

BOTTOM MOUNT features†



Model shown: WBE5100SB



Model shown: WBM5104SB

model	WBE5100SB	WBM5104SB
gross capacity (litres)	510	510
food compartment gross capacity (litres)	349	349
freezer compartment gross capacity (litres)	156	156
dimensions (and recommended clearances)	refer to page 27	refer to page 27
door finish	stainless steel	stainless steel
handle design	integrated	bar
frost-free	✓	✓
multi-flow air delivery system	✓	✓
internal electronic controls (door alarm, drinks chill timer, quick freeze function, holiday energy efficient mode)	✓	
separate temperature controls for fridge & freezer	✓	✓
fingerprint resistant surface	✓	✓
fridge features		
blue feature lighting	✓	
storesafe™ drawer with child latch	✓	✓
chill stream® air curtain	✓	✓
adjustable spillsafe™ glass shelves	3	3
bottle rack/caddy	✓/ –	✓/ –
easy glide crisper bins	✓	✓
humidity controlled crisper bins (separated)	✓	✓
humidity controlled crisper bin (full-width)		
dairy compartment (full-width)	✓	✓
bottle bins (half-width)	2	2
bottle bins full-width (with bottle fingers)	2(1)	2(1)
interior fridge light	✓	✓
freezer features		
easy glide freezer baskets	2	2
twist ice and serve with bucket and scoop/trays	✓/3	✓/3
food freezing guide	✓	✓
other features		
hidden hinges	✓	✓
door opening	left or right hand	left or right hand
adjustable front rollers	✓	✓
rear rollers	✓	✓
energy star rating (new)	2	2
energy star rating (on old scale)	4	
energy consumption (kwh/year)	545	580

† Refer to the product information on the back page of this brochure



Model shown: WBM5100WB

Model shown: WBE4300SB

Model shown: WBM4304SB

Model shown: WBM4300WB

Model shown: WBM3700WB

WBM5100WB	WBE4300SB	WBM4304SB	WBM4300WB	WBM3700SB/WB
510	430	430	430	370
349	300	300	300	243
156	131	131	131	122
refer to page 27	refer to page 27	refer to page 27	refer to page 27	refer to page 27
classic white	stainless steel	stainless steel	classic white	stainless steel/classic white
integrated	integrated	bar	integrated	integrated
✓	✓	✓	✓	✓
✓	✓	✓	✓	✓
	✓			
✓	✓	✓	✓	✓
✓	✓	✓	✓	✓
	✓			
✓	✓	✓	✓	✓
✓	✓	✓	✓	✓
3	3	3	3	2
-/✓	✓/-	✓/-	-/✓	-/✓
✓				
	✓	✓	✓	✓
✓	✓	✓	✓	✓
2	2	2	2	3
2(1)	2(1)	2(1)	2(1)	2(1)
✓	✓	✓	✓	✓
2	2	2	2	2
✓/3	✓/3	✓/3	✓/3	-/1
✓	✓	✓	✓	✓
✓	✓	✓	✓	✓
left or right hand	left or right hand	left or right hand	left or right hand	left or right hand
✓	✓	✓	✓	✓
✓	✓	✓	✓	✓
2	2	2	2	2
4	4	4	4	3.5
580	530	530	530	495

LARGE TOP MOUNTS

TOP MOUNTS – LARGE (390L-520L)[†]

Our top mounts with their eye-level freezer puts fresh food in reach of every member of the family. This ever-popular model comes loaded with great features.



INTERNAL ELECTRONIC CONTROLS

With easy-to-reach electronic functions* like Fast Freeze, Drink Chill Timer, Temperature Controls and Eco mode, your Westinghouse refrigerator can be quickly adjusted to suit you, your family and your lifestyle.



EASY GLIDE CRISPERS*

Crispers on telescopic extension slides give the family effortless access to fresh goods, even when full.



TWIST ICE AND SERVE

Twist ice and serve is an easy way to dispense ice.



CHILL STREAM®

A chill stream® air curtain is directed down the front of the fridge from the top compartment, keeping your drinks at the front perfectly cold without freezing items at the back.



FINGERPRINT-RESISTANT STAINLESS STEEL DOORS

The innovative fingerprint-resistant stainless steel doors ensure all Westinghouse stainless steel fridges maintain that sleek fingerprint-free look. In fact, a damp cloth should be all you need to remove marks from any Westinghouse fridge or freezer.



BLUE FEATURE LIGHTING

Available on selected models, blue feature lighting increases visibility and enhances the stylish design of the fridge interior.



ADJUSTABLE INTERIORS WITH SPILLSAFE™ GLASS SHELVES

With over 20 different shelving and door bin positions, you can easily fit the smallest deli items to the biggest party platters. Spillsafe™ glass shelves improve visibility and isolate leaks – preventing up to 1 litre of spills from dripping down to the shelves below.



INTEGRATED or BAR HANDLE

Selected models have bar handles whilst all others have integrated handles, giving you the choice of handle that suits your needs.

* Selected models only

† Refer to the product information on the back page of this brochure



Model shown: WTE5200SB

- 1** Adjustable interiors
- 4** Easy glide crispers
- 7** Spillsafe™ glass shelves
- 2** Internal electronic controls
- 5** Twist ice and serve
- 8** Bottle rack
- 3** Chill stream®
- 6** Blue feature lighting

TOP MOUNT – LARGE features†



Model shown: WTE5200SB

Model shown: WTM5200WB

Model shown: WTM5204SB

model	WTE5200SB	WTM5200WB	WTM5204SB
gross capacity (litres)	520	520	520
food compartment gross capacity (litres)	396	396	396
freezer compartment gross capacity (litres)	122	122	122
dimensions (and recommended clearances)	refer to page 27	refer to page 27	refer to page 27
door finish	stainless steel	classic white	stainless steel
handle design	integrated	integrated	bar
frost-free	✓	✓	✓
multi-flow air delivery system	✓	✓	✓
internal electronic controls (door alarm, drinks chill timer, quick freeze function, holiday energy efficient mode)	✓		
separate temperature controls for fridge & freezer	✓	✓	✓
fingerprint resistant surface	✓	✓	✓
fridge features			
blue feature lighting	✓		
storesafe™ drawer with child latch	✓	✓	✓
chill stream® air curtain	✓	✓	✓
adjustable spillsafe™ glass shelves	3	3	3
repositional deli compartment	✓	✓	✓
bottle rack/caddy	✓/–	–/✓	✓/–
easy glide crisper bins	✓		✓
humidity controlled crisper bins (separated)	✓	✓	✓
humidity controlled crisper bin (full width)			
dairy compartment (full-width)	✓	✓	✓
door bins (half-width)	2	2	2
bottle bin full-width (with bottle fingers)	2 (1)	2 (1)	2 (1)
utility drawer	✓	✓	✓
interior fridge light	✓	✓	✓
freezer features			
freezer door bins (full-width)	2	2	2
adjustable glass shelf	✓	✓	✓
twist ice and serve/trays	✓/3	✓/3	✓/3
interior freezer light	✓		✓
other features			
hidden hinges	✓	✓	✓
door opening	left or right hand	left or right hand	left or right hand
adjustable front rollers	✓	✓	✓
rear rollers	✓	✓	✓
energy star rating (new)	2.5	2.5	2.5
energy star rating (on old scale)	4.5	4.5	
energy consumption (kwh/year)	507	518	518

† Refer to the product information on the back page of this brochure

NEW



Model shown: WTM4404SB



Model shown: WTM4400WB



Model shown: WTE4200SB



Model shown: WTM4200WB



Model shown: WTM3900WB

WTM4404SB	WTM4400WB	WTE4200SB	WTM4200WB	WTM3900SB/WB
440	440	420	420	390
339	339	315	315	302
103	103	103	103	91
refer to page 27	refer to page 27	refer to page 27	refer to page 27	refer to page 27
stainless steel	classic white	stainless steel	classic white	stainless steel/classic white
bar	integrated	integrated	integrated	integrated
✓	✓	✓	✓	✓
✓	✓	✓	✓	✓
		✓		
✓	✓	✓	✓	✓
✓	✓	✓	✓	✓
		✓		✓
✓	✓	✓	✓	✓
✓	✓	✓	✓	✓
3	3	3	3	3
✓	✓	✓	✓	✓
✓/-	-/✓	✓/-	-/✓	-/✓
✓	✓	✓	✓	✓
✓	✓	✓	✓	✓
2	2	2	2	2
2 (1)	2 (1)	2/✓	2/✓	1/✓
✓	✓	✓	✓	✓
✓	✓	✓	✓	✓
2	2	2	2	2
✓	✓	✓	✓	✓
✓/3	✓/2	✓/2	✓/2	✓/2
✓		✓		
✓	✓	✓	✓	✓
left or right hand	left or right hand	left or right hand	left or right hand	left or right hand
✓	✓	✓	✓	✓
✓	✓	✓	✓	✓
2.5	2.5	2.5	2.5	2.5
	4	4	4	4
484	484	468	456	450

appliances online

COMPACT TOP MOUNTS

TOP MOUNTS – COMPACT (180L-330L)[†]

A small fridge that thinks it's a big fridge – or perhaps that should be the other way round. Offering the capacity and features normally found in larger models, these fridges offer the best of both worlds for homes where kitchen space is at a premium.



ADJUSTABLE INTERIORS

With easily repositionable and removable shelves and bins, you have over 20 different shelving and door bin positions, allowing you to fit the smallest deli items to the biggest party platters. (On selected models.)



SPECIALISED COMPARTMENTS

Keep your fruit and vegetables fresh with humidity controlled crispers while the chiller compartment allows you to store perishable food for longer.



FINGERPRINT-RESISTANT STAINLESS STEEL DOORS

The innovative fingerprint-resistant stainless steel doors ensure all Westinghouse stainless steel fridges maintain that sleek fingerprint-free look. In fact, a damp cloth should be all you need to remove marks from any Westinghouse fridge or freezer.



LARGE CAPACITY FRIDGE

More fridge space where you need it most! Up to 255 litres dedicated to the fridge compartment, for all your fresh food requirements.



MULTI-FLOW

The multi-flow airflow system maintains an even temperature throughout – keeping your food fresher for longer.



SPILLSAFE™ GLASS SHELVES

Selected models are fitted with adjustable, durable glass shelves which contain spills and can be wiped clean with ease. Selected models come with a spill-safe™ glass shelf in the freezer.



BOTTLE CADDY

On selected models, a ridged caddy lets you keep up to six bottles stacked neatly for easy access.



TWIST ICE AND SERVE

Twist ice and serve is an easy way to dispense ice. (On selected models)

[†] Refer to the product information on the back page of this brochure



Model shown: WTM3300PB

- 1 Adjustable interiors
 - 2 Specialised compartments
 - 3 Specialised storage
- 4 Twist ice and serve
 - 5 Multi-flow
- 6 Spillsafe™ glass shelves
 - 7 Bottle caddy

TOP MOUNT – COMPACT features†



Model shown: WTM3300PB



Model shown: WTM3000WB

model	WTM3300PB/WB	WTM3000PB/WB
gross capacity (litres)	330	300
food compartment gross capacity (litres)	255	227
freezer compartment gross capacity (litres)	75	75
dimensions (and recommended clearances)	refer to page 27	refer to page 27
door finish	pacific silver/classic white	pacific silver/classic white
frost-free	✓	✓
multi-flow air delivery system	✓	✓
separate temperature controls for fridge & freezer	✓	✓
fridge door alarm		
fingerprint resistant surface	✓/-	✓/-
fridge features		
adjustable spillsafe™ glass shelves	3	3
adjustable wire shelves		
full-width chiller compartment		
deli compartment	✓	✓
bottle caddy	✓	✓
full-width humidity controlled crisper bin	✓	✓
crisper bin		
dairy compartment	✓	✓
full-width door bins	2	2
half-width door bins	2	2
bag clips		
interior fridge light	✓	✓
freezer features		
adjustable spill safe glass shelves	1	1
wire/plastic shelves		
twist ice server/storage bin	2/✓	2/✓
ice cube trays/storage bin		
meat drawer		
full-width door bins	1	1
other features		
R600a refrigerant		
hidden hinges	✓	✓
door opening	conversion kit ¹	conversion kit ¹
rear rollers	✓	✓
levelling legs	✓	✓
energy star rating (new)	2	2
energy star rating (on old scale)	4	4
energy consumption (kwh/year)	437	424

¹For those wanting a left hand opening model for WTM3300PB/WB, WTM3000PB/WB and WTM2800PB/WB please order AREX00WA.

²For those wanting a left hand opening model for WTB2500PB/WB and WTB2300PB/WB please order AREX01WA

† Refer to the product information on the back page of this brochure



Model shown: WTM2800PB



Model shown: WTB2500WB



Model shown: WTB2300PB



Model shown: WTM2000WC



Model shown: WTM1800WC

WTM2800PB/WB	WTB2500PB/WB	WTB2300PB/WB	WTM2000WC	WTM1800WC
280	250	230	200	180
209	167	161	144	127
75	79	65	59	54
refer to page 27	refer to page 27	refer to page 27	refer to page 27	refer to page 27
pacific silver/classic white	pacific silver/classic white	pacific silver/classic white	classis white	classic white
✓	✓	✓	✓	✓
✓	✓	✓	✓	✓
✓	✓	✓	✓	✓
	✓	✓		
✓/-	✓/-	✓/-		
2	2	2		
			3	3
	✓	✓		
✓				
	✓	✓		
			✓	✓
✓	✓	✓	✓	✓
2	2	2	3	3
2	2	2	2	2
	✓	✓		
✓	✓	✓	✓	✓
1				
	-/1	-/1	1/-	1/-
2/✓	2/✓	2/✓		
			2/✓	2/✓
	✓	✓		
1	2	1	1	1
	✓	✓	✓	✓
✓	✓	✓	✓	✓
conversion kit ¹	conversion kit ²	conversion kit ²	reversible	reversible
✓	✓	✓	✓	✓
✓	✓	✓	✓	✓
2	2	2	2	2
4	3.5	3.5	4	4
413	414	394	360	341

¹ Refer to the product information on the back page of this brochure

VERTICALS & PIGEON PAIRS

VERTICALS AND PIGEON PAIRS

Westinghouse's vertical fridges and freezers can be combined in one space to give you a pigeon pair. This provides you with the maximum fresh food and freezer storage in one unit – truly the big fridge for the big family. Or they can be placed in separate places to give you best utilisation of space in your kitchen/home. Best of all, their interior is as flexible as their exterior.



EASY GLIDE CRISPERS AND FREEZER BINS*

Telescopic freezer bins and fridge crispers give the whole family quick and easy access without the effort – even when they're full.



TWIST ICE AND SERVE

Twist ice and serve is an easy way to dispense ice.



ADJUSTABLE INTERIORS

With over 20 different shelving and door bin positions, you can easily fit the smallest deli items to the biggest party platters.



SPILL SAFE GLASS SHELVES

Spill safe glass shelves improve visibility and isolate leaks – preventing up to 1 litre of spills from dripping down to the shelves below.



CHILL STREAM®

A chill stream® air curtain is directed down the front of the fridge from the top compartment, keeping your drinks at the front perfectly cold without freezing items at the back.

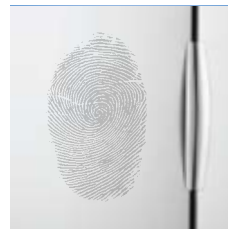

FINGERPRINT-RESISTANT STAINLESS STEEL DOORS

The innovative fingerprint-resistant stainless steel doors ensure all Westinghouse stainless steel fridges maintain that sleek fingerprint-free look. In fact, a damp cloth should be all you need to remove marks from any Westinghouse fridge or freezer.



BOTTLE CADDY

All models have bottle caddies – providing you with a practical solution for storing and organising all kinds of bottles.



ENVIRONMENTALLY FRIENDLY

Westinghouse refrigerators and freezers have started converting over to the less harmful R600a refrigerant. Look out for this symbol, as well as, R600a in the specification tables, to see which models have already changed over.

* Selected models only



Freezer Model: WFM3600SB

Model shown: WRM4300SB

- 1 Adjustable interiors
- 2 Easy glide crisper
- 3 Chill stream®
- 4 Repositional deli compartment
- 5 Storesafe™ drawer
- 6 Spill safe glass shelves
- 7 Bottle storage
- 8 Bottle Caddy
- 9 Twist ice and serve
- 10 Easy glide freezer bins

SINGLE DOOR FRIDGES features[†]



Model shown: WRM4300SB



Model shown: WRM3700PB



Model shown: WRM2400WC

model	WRM4300SB/WB	WRM3700PB/WB	WRM2400SC/WC
gross capacity (litres)	430	370	240
door finish	stainless steel/classic white	pacific silver/classic white	stainless steel/classic white
dimensions (and recommended clearances)	refer to page 26	refer to page 26	refer to page 26
door opening	left or right hand available	left or right hand available	reversible
frost-free	✓	✓	
separate temperature control	✓	✓	✓
chill stream air curtain	✓	✓	
multi-flow air delivery system	✓	✓	
fridge features			
adjustable deli compartment	✓	✓	
bottle caddy	✓	✓	
easy glide crisper bins	✓		
storesafe™ drawer with child latch	✓		
adjustable spill safe slide out glass shelves	✓	✓	
full width crisper bin	✓	✓	✓
humidity controlled crisper bin	✓	✓	
dairy compartment (full width) with lid	✓	✓	✓
adjustable full width bottle bins	2	2	3
bottle fingers	2	2	
egg tray	✓	✓	✓
interior fridge light	✓	✓	✓
other features			
R600a refrigerant			✓
adjustable front rollers	✓	✓	
adjustable front levelling leg			✓
rear rollers	✓	✓	
energy star rating (new)	1.5	1.5	2
energy star rating (on old scale)	5.5	5.5	6
energy consumption (kwh/year)	380	353	265

[†] Refer to the product information on the back page of this brochure

VERTICAL FREEZERS features[†]



Model shown: WFM3600SB



Model shown: WFM3000PB



Model shown: WFM1800WC

model	WFM3600SB/WB	WFM3000PB/WB	WFM1800SC/WC
gross capacity (litres)	360	300	180
door finish	stainless steel/classic white	pacific silver/classic white	stainless steel/classic white
dimensions (and recommended clearances)	refer to page 26	refer to page 26	refer to page 26
door opening	left or right hand available	left or right hand available	reversible
frost-free	✓	✓	
separate temperature control	✓	✓	✓
multi-flow air delivery system	✓	✓	
freezer features			
easy glide baskets	✓		
twist ice and serve/trays	✓/2	✓/2	-/1
ice cube storage bin	✓	✓	✓
adjustable glass shelves	3	5	
full-width freezer baskets	3	1	6
freezer light	✓	✓	
other features			
R600a refrigerant			✓
adjustable front rollers	✓	✓	
adjustable front levelling leg			✓
rear rollers	✓	✓	
energy star rating	1.5	1.5	2.5
energy star rating	3.5	3.5	5
energy consumption (kwh/year)	569	525	297

[†] Refer to the product information on the back page of this brochure

DIMENSIONS

LARGE SIDE BY SIDE MODELS†

WSE6970SA, WSE6970PA, WSE6970WA, WSE7000SA, WSE7000PA, WSE7000WA

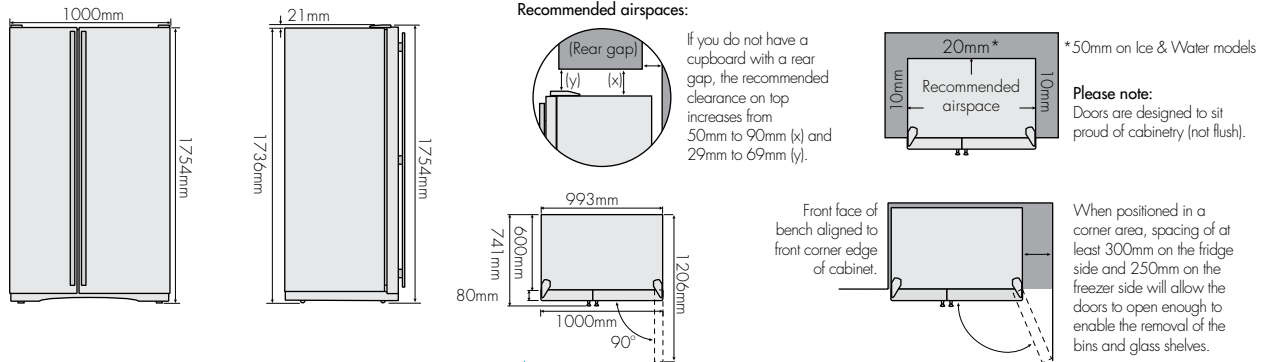

COMPACT SIDE BY SIDE MODELS†

WSE6070SB, WSE6070WB, WSE6100SA, WSE6100PA, WSE6100WA

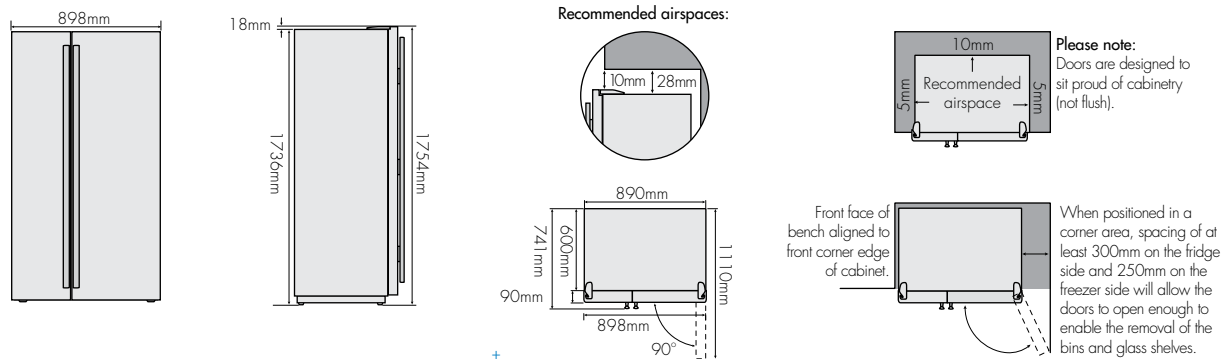

VERTICALS AND PIGEON PAIRS†

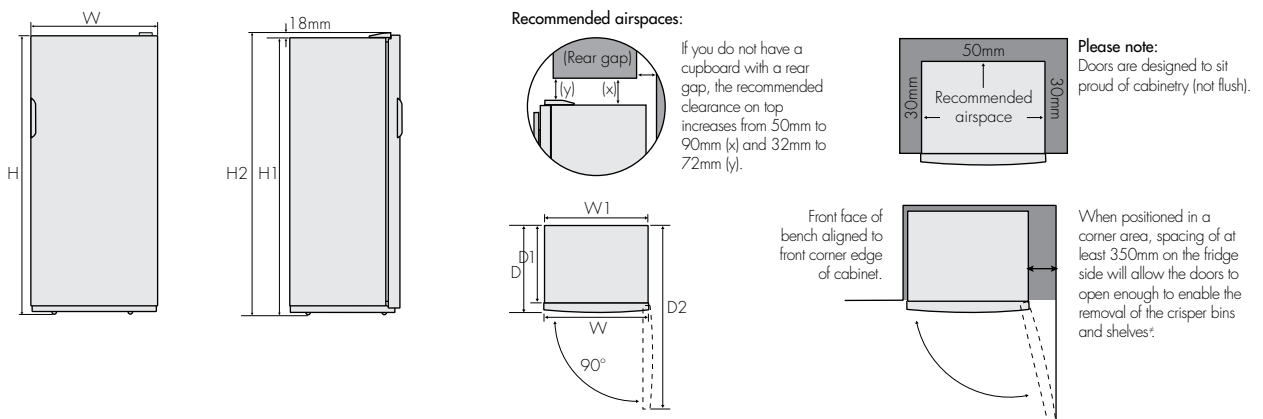

model	max door height (H)	cabinet height (H1)	total height (H2)	door width (W)	cabinet width (W1)	total depth (D)	cabinet depth (D1)	depth door open (D2)
WRM4300SB, WRM4300WB	1714	1702	1720	703	690	647	550	1299
WRM3700PB, WRM3700WB	1714	1702	1720	608	595	647	550	1204
WRM2400SC, WRM2400WC	1441	1441	1441	545	540	570	485	1079
WFM3600SB, WFM3600WB	1714	1702	1720	703	690	647	550	1299
WFM3000PB, WFM3000WB	1714	1702	1720	608	595	647	550	1204
WFM1800SC, WFM1800WC	1441	1441	1441	545	540	570	485	1079

† Refer to the product information on the back page of this brochure. *For those single door models with telescopic extension slide-out bins or crispers situated with the door opening against the wall, clearance requirement increases from 350mm to 450mm.

For information on installation of integration kits for top mounts, bottom mounts and pigeon pair models, please refer to www.westinghouse.com.au

BOTTOM MOUNT MODELS†

WBE5100SB, WBM5100PB, WBM5100WB,
WBE4300SB, WBM4300PB, WBM4300WB,
WBM3700SB, WBM3700WB

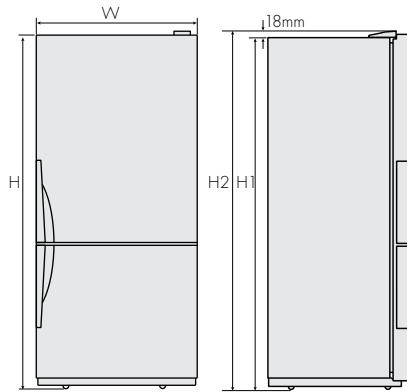

LARGE TOP MOUNT MODELS†

WTE5200SB, WTM5200PB, WTM5200WB,
WTM4400WB, WTE4200SB, WTM4200PB,
WTM4200WB, WTM3900SB, WTM3900WB

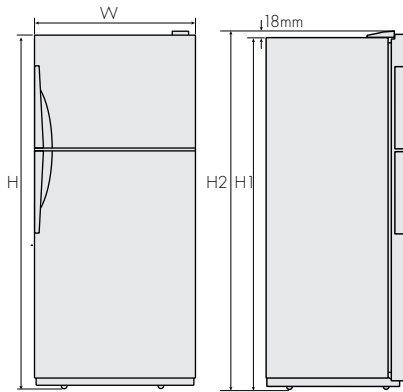

COMPACT TOP MOUNT MODELS†

WTM3300PB, WTM3300WB, WTM3000PB,
WTM3000WB, WTM2800PB, WTM2800WB,
WTB2500PB, WTB2500WB, WTB2300PB,
WTB2300WB, WTM2000WC, WTM1800WC

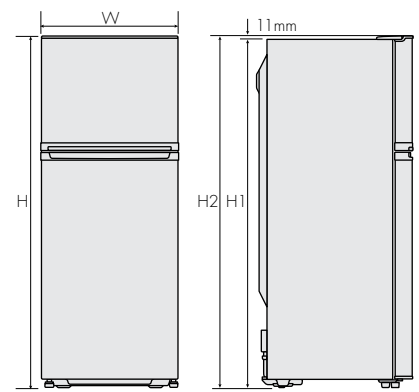

Recommended airspaces:

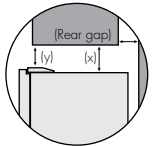

If you do not have a cupboard with a rear gap, the recommended clearance on top increases from 50mm to 90mm (x) and 32mm to 72mm (y).

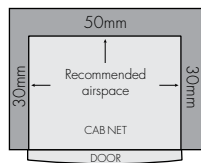

Please note:
Doors are designed to sit proud of cabinetry (not flush).

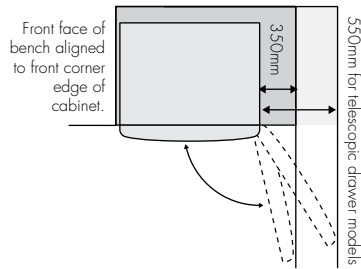

550mm for telescopic drawer models
When positioned in a corner area, spacing of at least 350mm on the fridge side will allow the doors to open enough to enable the removal of the crisper bins and shelves. This required clearance increases to 550mm for those models with telescopic extension slide-out bins.

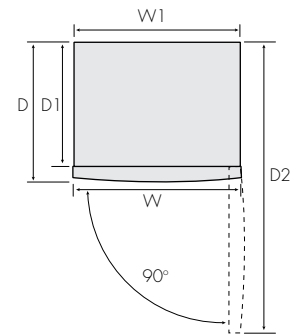

model	max door height (H)	cabinet height (H1)	total height (H2)	door width (W)	cabinet width (W1)	total depth (D)	cabinet depth (D1)	depth door open (D2)
WBE5100SB, WBM5100PB, WBM5100WB	1714	1702	1720	803	790	709	612	1450
WBM5104SB	1714	1702	1720	803	790	725	612	1450
WBE4300SB, WBM4300PB, WBM4300WB	1714	1702	1720	703	690	709	612	1350
WBM4304SB	1714	1702	1720	703	690	725	612	1350
WBM3700SB, WBM3700WB	1614	1602	1620	652	640	709	612	1269
WTE5200SB, WTM5200PB, WTM5200WB	1714	1702	1720	803	790	709	612	1450
WTM5204SB	1714	1702	1720	803	790	725	612	1450
WTM4400WB	1714	1702	1720	703	690	709	612	1350
WTM4404SB	1714	1702	1720	703	690	725	612	1350
WTE4200SB, WTM4200PB, WTM4200WB	1634	1622	1640	703	690	709	612	1350
WTM3900SB, WTM3900WB	1714	1702	1720	703	690	647	550	1288
WTM3300PB, WTM3300WB	1714	1702	1720	607	595	647	550	1193
WTM3000PB, WTM3000WB	1614	1602	1620	607	595	647	550	1193
WTM2800PB, WTM2800WB	1544	1532	1550	607	595	647	550	1193
WTB2500PB, WTB2500WB	1458	1450	1491	543	540	620	540	1094
WTB2300PB, WTB2300WB	1356	1348	1389	543	540	620	540	1094
WTM2000WC	1476	1472	1476	524	520	595	500	1070
WTM1800WC	1400	1400	1400	494	490	580	490	1029

† Refer to the product information on the back page of this brochure. *For those top mount and bottom mount models with telescopic extension slide-out bins or crispers being placed in location with the door opening against the wall, clearance requirement increases from 350mm to 550mm.

For information on installation of integration kits for top mounts, bottom mounts and pigeon pair models, please refer to www.westinghouse.com.au

**For more information on all Westinghouse appliances,
or for dimension and installation information, call into your retailer,
phone or email our customer care team or visit our website:**

phone: 1300 363 640
fax: 1800 350 067
email: customercare@electrolux.com.au
web: www.westinghouse.com.au

**Westinghouse. We are part of the Electrolux family.
Share more of our thinking at www.electrolux.com.au**



TOP SERVICE

Top Service encompasses the after sales service provided by The Electrolux Group to consumers including delivery, home service and spare parts.

WARRANTY

Electrolux Home Products Pty Ltd warrants that for domestic application, the Westinghouse products featured in this brochure are free from defects in materials and workmanship for a period of 2 years (3 months for commercial applications) from the date of first purchase, subject to the conditions set out in the warranty card accompanying the product when purchased. An additional 3 year warranty is also provided for domestic applications to cover replacement of parts for the sealed refrigeration system only.

† PRODUCT INFORMATION

The descriptors and illustrations in this publication apply to the specific products and models described as at the date of issue. Under our policy of continuous product development, product specifications may change without notice. Prospective purchasers should therefore check with their retailer to ensure this publication correctly describes the products that are being offered for sale. All information supplied is to be used for general reference purposes only and is on the understanding that Electrolux Home Products Pty Ltd will not be liable for any loss, liability or damage of whatever kind arising as a result of reliance on such information. Colours of products illustrated are as close as printing limitations allow.

Chill stream®, Spillsafe™ and storesafe™ are registered trademarks of Electrolux Home Products Pty Ltd

© 2010 Electrolux Home Products Pty Ltd ABN 51 004 762 341 Print code: WFRI_Jul 10



Printed on Monza Gloss Recycled Art stock containing 55% recycled material & 45% from sustainable forests.



Westinghouse