

# USER MANUAL

GHP16S, GHP16W, GHP17S,  
GHP17W, GHP765S, GHP775S,  
GHP95S, GHP95W, GHP795S



GAS COOKTOPS



Westinghouse

# CONTENTS

## CONGRATULATIONS

Congratulations and thank you for choosing our Product. We are sure you will find your new cooktop a pleasure to use and a great asset to your cooking. Before you use the cooktop, we recommend that you read through the whole user manual which provides the description of the cooktop and its functions.

To avoid the risks that are always present when you use a gas appliance, it is important that the cooktop is installed correctly and that you read the safety instructions carefully to avoid misuse and hazards. For future reference, please store this booklet in a safe place.

## CONTENTS

Important safety instructions . . . . .	3
Installation and use summary . . . . .	4
Cleaning and care . . . . .	5
Troubleshooting . . . . .	6
Installation instructions . . . . .	7
Installation procedure . . . . .	8
Gas connection . . . . .	10
Operation on NG/SNG . . . . .	10
LPG conversion . . . . .	12
Electrical connection . . . . .	13
Testing appliance operation . . . . .	14
Warranty . . . . .	15

## IMPORTANT SAFETY INSTRUCTIONS

Please read the user manual carefully and store in a handy place for later reference. The symbols you will see in this booklet have these meanings:



### WARNING

This symbol indicates information concerning your personal safety



### CAUTION

This symbol indicates information on how to avoid damaging the appliance



### TIPS & INFORMATION

This symbol indicates tips and information about use of the appliance



### ENVIRONMENTAL TIPS

This symbol indicates tips and information about economical and ecological use of the appliance

Meanings of symbols used in this manual are shown below:



This symbol indicates never to do this



This symbol indicates always do this



### TIPS & INFORMATION

**IMPORTANT – CHECK FOR ANY DAMAGE OR MARKS.** If you find the cooktop is damaged or marked, you must report it within 7 days if you wish to claim for damage/marks under the manufacturer's warranty. This does not affect your statutory rights.



### ENVIRONMENTAL TIPS

#### Information on disposal for users

- Most of the packing materials are recyclable. Please dispose of those materials through your local recycling depot or by placing them in appropriate collection containers.
- If you wish to discard this product, please contact your local authorities and ask for the correct method of disposal.

## WARNING

- ⊘ This appliance is not intended for use by persons (including children) with reduced physical, sensory or mental capabilities, or lack of experience and knowledge, unless they have been given supervision or instruction concerning use of the appliance by a person responsible for their safety.
- ✓ Children should be supervised to ensure they do not play with this appliance.
- ✓ During use, this appliance becomes hot. Care should be taken to avoid touching hot surfaces. To avoid burns, young children should be kept away.
- ⊘ This appliance must not be used as a space heater.
- ✓ Keep vents clear of obstructions.
- ✓ In order to avoid a fire, this appliance must be kept clean.
- ⊘ Do not spray aerosols in the vicinity of this appliance while it is in operation.
- ⊘ Do not store flammable materials in or under this appliance, e.g. aerosols.
- ⊘ Do not allow pots to boil dry, as damage to both pan and cooktop may result.
- ⊘ Do not operate the cooktop for an extended period of time without a pot or pan on the hotplate.
- ⊘ Do not allow large cookware to overhang the cooktop onto the adjacent benchtop. This will cause scorching to the benchtop surface.
- ⊘ Do not allow cooking pots or pans to intrude into the area which is close to the controls.
- ✓ Ensure burner caps and trivets are properly located. (See Figure 1)
- ✓ For maximum stability, ensure pots and pans are centrally located on the trivets.
- ✓ Handles should be turned away from the front of the bench to avoid accidents.
- ✓ Do not modify this appliance.

Figure 1

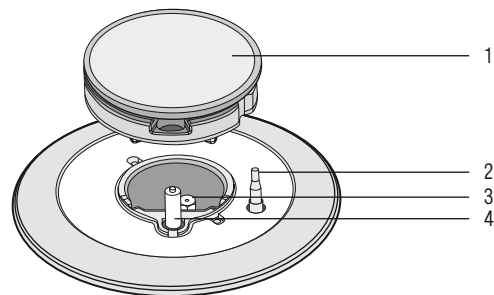

- |   |                       |
|---|-----------------------|
| 1 Burner                                | 3 Injector            |
| 2 Flame safeguard sensor (where fitted) | 4 Ignition spark plug |

# INSTALLATION & USE

## INSTALLATION

**NOTE:** You must read these warnings carefully before installing or using the cooktop. If you need assistance, contact your Customer Care Department. The manufacturer will not accept liability, should the instructions below or any other safety instructions incorporated in this book be ignored.

### INSTALLATION

- An authorised person must install this appliance and **MUST provide a certificate of compliance**. This certificate should be retained along with purchase information.
- Before using the appliance, ensure that all packing materials are removed from the appliance.
- In order to avoid any potential hazard, the installation instructions in this booklet, and any labels on the appliance must be followed.
- Ensure that all specified vents, openings and air spaces are not blocked.
- Where the appliance is built into a benchtop, the benchtop material must be capable of withstanding 85°C.
- Ensure that the duplicate rating label (in the instruction pack) is attached to a readily-accessible adjacent surface, so that the cooktop can be easily identified in the case of a service call.

### SERVICING

- Servicing **MUST** only be carried out by authorised personnel.
- To maintain safe operation, it is recommended that the product be inspected every five years by an authorised service person.
- If the supply cord is damaged, it must be replaced by an authorised service person in order to avoid a hazard.

### CLEANING

- Always ensure the appliance is turned off before cleaning.
- This appliance contains aluminium fittings. Do not use caustic-based cleaners.
- Do not use steam cleaners, as this may cause moisture build up on electrical components.
- Always clean the appliance immediately after any food spillage.

### CAUTION

- DO NOT place burners in a dishwasher.

### CONTROLS

- Each burner is controlled by a control knob. The markings on the control panel indicate which burner the knob controls, and the settings for that burner. (See Figure 2)

## USING YOUR COOKTOP

**Note:** Gas controls turn anticlockwise from 'Off' and have limited movement.

Figure 2

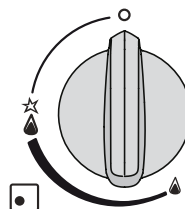



### LIGHTING BURNERS

#### Electronic ignition

These cooktops are fitted with mains powered ignition. When the appliance has been connected and the power is on, depressing any knob will release sparks to all burners. To light a burner, depress the corresponding knob and turn to the 'High'  position (while depressing the knob). The knob may be released once the flame is established.

#### Flame safeguard models

The knob must be turned to the 'High'  position, then pushed down as far as possible for approximately 5 seconds. If the flame goes out when the knob is released, simply depress the knob again, this time holding it down with slightly more force for the same length of time. The height of the flame can be varied by turning the control knob toward the 'Low'  position.

### WARNING

- Keep hands clear of burners when lighting.
- If burner does not light within 5 seconds, turn knob to 'Off' position, allow gas to disperse, then try lighting again.
- Burners **MUST** be operated between 'HIGH' and 'LOW' settings only.

In the absence of electrical power, carry out the ignition directly to the burner with a hand-held ignition source.

### Choice of burners

For your convenience there is a choice of burners:

- A small burner for special low heat and slow cooking.
- A medium burner for normal cooking and simmering. (one on 4-burner models and two on 5-burner models).
- A large burner for fast heating and large pots and pans.
- A wok burner for very fast heating using a wok or large pot or pan.

To conserve gas, place the pan centrally over the burner and adjust the flame so that it does not extend past the edge of the pan (Figure 3). Do not boil food too rapidly. A vigorous boil will not cook food any faster, and will waste energy.

## Pots and pans

All common pots and pans: aluminium, stainless steel, cast iron, ceramic, etc., may be used on your new gas model cooktop. Ensure that the pots or pans are steady and have flat bases to avoid dangerous spill-over of hot liquids and wasted energy. A wok support has been supplied with this appliance for use when cooking with a round-bottom wok. The support is not necessary when cooking with a flat-bottom wok.

Figure 3

### Choice of Flame Height

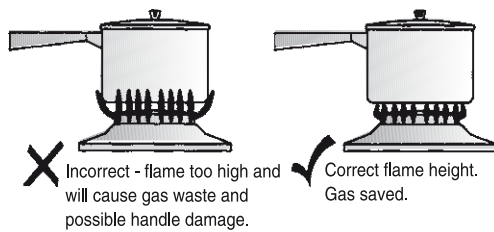

### Choice of Cooking Utensils

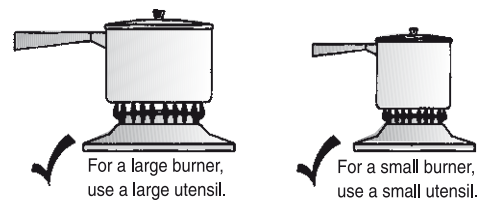

## WARNING

Never use asbestos mats, wire mats or grids, aluminium foil as it can lead to overheating, cracked enamel. The warranty will be void if these items are used and cause a failure. Woks should only be used on the wok burner and wok support trivet.

## CLEANING & CARE

## CAUTION

Ensure the appliance is off and cool before cleaning.

### Enamel

Persistent stains may require rubbing with a nylon scourer or creamed powder cleansers. Household enamel cleaners are available, follow the manufacturer's instructions in their use.

## CAUTION

Harsh abrasive cleaners, powder cleaners, steel wool or wax polishes should not be used.

### Stainless steel

**Note:** Ensure any oil is cleaned off the hob before first use, otherwise it may cause the hob to turn a yellowish colour.

All grades of stainless steel may stain, discolour or attain an adhering layer of grime in normal operation. To achieve maximum surface appearance, stainless steel must be kept clean by regularly using the following cleaning procedures, thus ensuring good performance and long service life.

Wash with warm soapy water and rinse with clean water. Where the stainless steel has become extremely dirty with signs of surface discolouration, (due to periods of neglect or misuse) use a stainless steel cleaner.

## CAUTION

DO NOT use abrasive scourers or steel wool. When removing these stains be sure to follow the polish or brushing lines.

### Trivets and burners

These can all be lifted off and removed for separate cleaning. This appliance is fitted with single-piece burners (except triple ring wok burner) for ease of cleaning. The burners and trivets are removable for easy cleaning.

**Note:** When refitting the burners, ensure that they are correctly seated.

Ensure burners are thoroughly dried after cleaning or spillage. When cleaning the burners, ensure that all the flame ports are free of any blockage. If necessary, use a toothpick or brush to clear ports. The outer surface of the burners have a polished finish and extra care needs to be taken to avoid scratching this surface during cleaning. In instances of heavy soiling, it may be necessary to apply a non-abrasive cleaning compound and rub with a cloth until the soiling is removed and then finish with a soft, dry cloth.

**Note:** DO NOT place burners in the dishwasher.

### Ignition

GENTLY clean the spark plug and flame safe guard sensor (where fitted) with a damp cloth to avoid lighting difficulties. Ensure the electrode is dry before use.

### Injector

Ensure the injector remains free of any foreign material. If necessary, use a thin piece of wire to clear the orifice.

# TROUBLESHOOTING

If you have a problem with the cooktop, check the table below. You may be able to solve the problem and this will save you from paying for a service call. You will have to pay for a service call even in the warranty period if the problem is one listed below.

FAULT	POSSIBLE CAUSES	REMEDY
Burner will not light even though the sparker is working.	• Knob not held down long enough in 'High' position for flame safeguard (where fitted) to engage	• Repeat lighting procedure and hold knob down for 5 seconds in 'High' position (refer page 4)
	• Gas supply valve turned off	• Turn on gas supply to appliance
	• Wrong knob turned	• Ensure the knob you are turning corresponds to the burner you want to light
	• Port blockage in ignition area	• Ensure that ports in ignition area are clean and dry
	• Ignition spark plugs wet or dirty	• Dry or clean ignition spark plugs
No spark is obtained when control knob is activated	• Electricity supply is disconnected or switched off	• Switch on electricity or check fuses
	• Ignition spark plugs wet or dirty	• Dry or clean ignition spark plugs
Flames uneven or tending to lift	• Flame ports blocked or wet	• Clean or dry flame ports
	• Burner incorrectly fitted	• Ensure this component is fitted correctly
Flames not staying on when knob released	• Knob not held down long enough in 'High' position for flame safeguard (where fitted) to engage	• Repeat lighting procedure and hold knob down for 5 seconds in 'High' position (refer page 4)
	• Knob not set between 'High' and 'Low'	• Knob MUST be set between these positions.
	• Dirt or spillage on flame safeguard sensor (where fitted)	• Clean flame safe guard sensor tip
Low heat, slow cooking	• Incorrect cooking pot or pan being used	• Refer to Figure 3 (page 5)
Benchtop or knobs overheating	• Incorrect cooking pot or pan used	• Check Figure 3 for correct pot or pan to be used
	• Pot or pan not located on burner properly	• Ensure pot or pan is centrally located on burner

If the above points have been checked and there is still a problem with the cooktop, please call the Service Centre.



## INSTALLATION INSTRUCTIONS

This appliance must be installed by an authorised person and in compliance with :

1. AS 5601 'Gas Installations' (Australia) or NZS 5261 'Installation of Gas Burning Appliances and Equipment' (New Zealand) or the relevant installation code for gas appliances of your country.
2. The local gas fitting regulations, municipal building codes, electrical wiring regulations and any other relevant statutory regulations.
3. The particular instructions as given below.

### CAUTION

Cooktops are supplied for use with natural gas (NG). To use on LPG the injectors **MUST** be changed using the conversion kit supplied. Refer LP Conversion on page 12.

4. A certificate of compliance **MUST** be given to the customer after the appliance is successfully installed.
5. This appliance must be earthed.

Figure 4 – 60cm and 75cm models cut-out

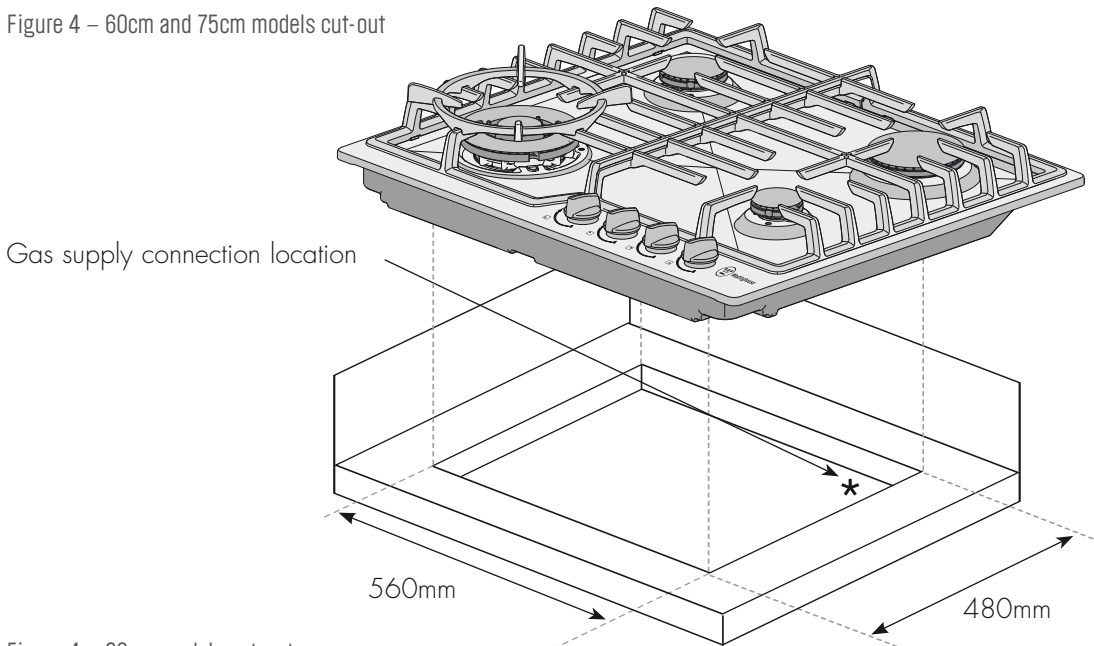
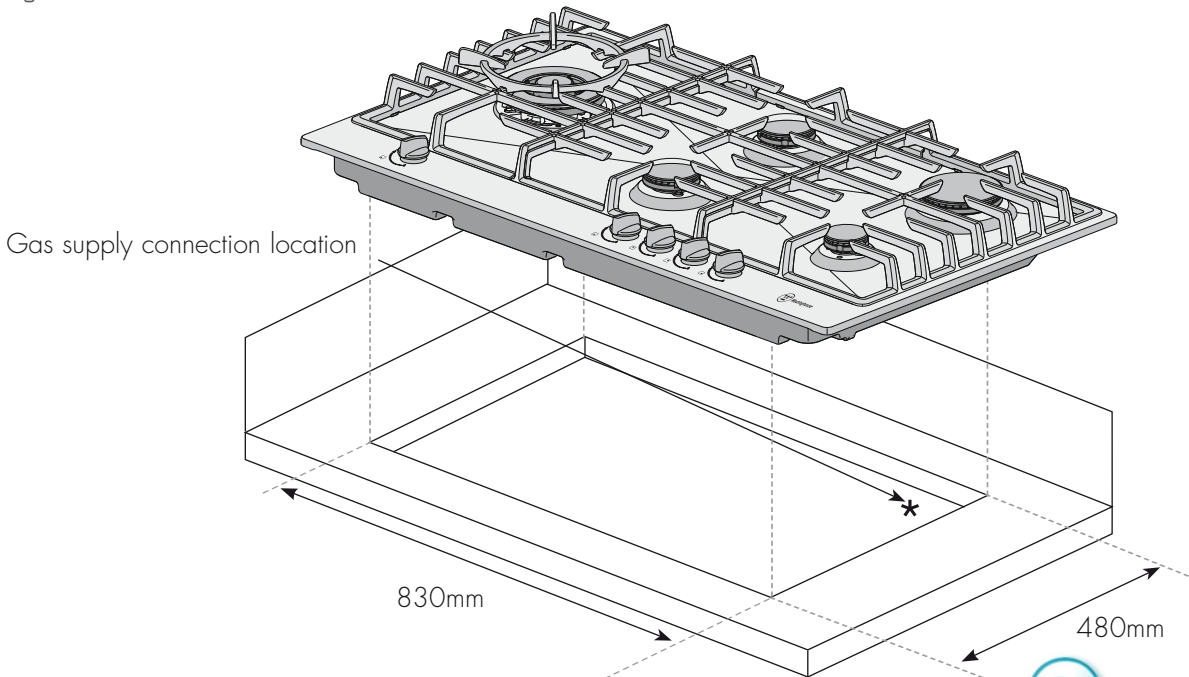

Figure 4 – 90cm models cut-out



# INSTALLATION

## INSTALLATION PROCEDURE

1. The bench cutout should be made as per cutout dimensions in Figure 4.
2. **Adjacent walls, cupboards and protection for combustible materials.**  
Ensure that the appliance is installed with Section 5.12.1 of AS 5601 (Australia) or section 14.1 of NZS 5261 (New Zealand), regarding clearances to combustible surfaces and materials, and clearances to rangehoods and exhaust fans. To ensure clearances of 200mm from burners to vertical combustible surfaces observe the minimum dimensions shown in Figure 5. Clearances to combustible materials may be reduced if combustible surfaces are protected in accordance with clause 5.12.1.2 of AS 5601 (Australia) or section 14.1.2 of NZS 5261 (New Zealand).
3. **Optional Barrier**  
A barrier can be installed to prevent accidental contact with the cooktop base, where the base of the cooktop is accessible from below (i.e. inside a cupboard, etc). An impression has been incorporated into the base to ensure a minimum clearance of 15mm is maintained between the base and the barrier. This barrier may be made of any non-combustible, rigid material.
4. **Fitting the cooktop into the bench**  
Carry out as follows:
  - Place the seals supplied around the bench cutout as shown in Figure 6, taking care that the seals meet without overlapping.
  - Fit the pull-down clamps supplied to ensure that the cooktop cannot move after installation.

### WARNING

Failure to fix the cooktop to the bench could result in loosening of the gas connection through movement of the cooktop and a gas leak may result.

- Use the 4 clamps and screws supplied in the parts bag for 4 burner models, and 6 clamps and screws for 5 burner models.
- To assemble, attach the clamps to each corner of the burner box via the screws provided.
- Fix the clamps as shown in Figure 7. The clamp location points are shown in Figure 8.
- Remove excess seal.
- If the benchtop is less than the standard 33mm thickness, use a packer between the bench and the pull down clamps to ensure the cooktop is properly secured.

Figure 5 – 60cm models

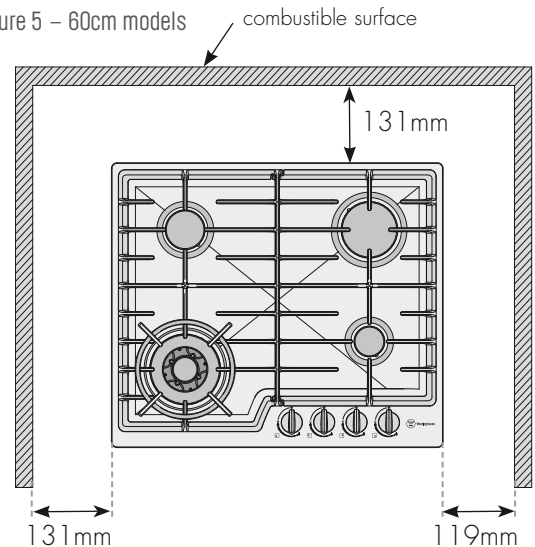

Figure 5 – 75cm models

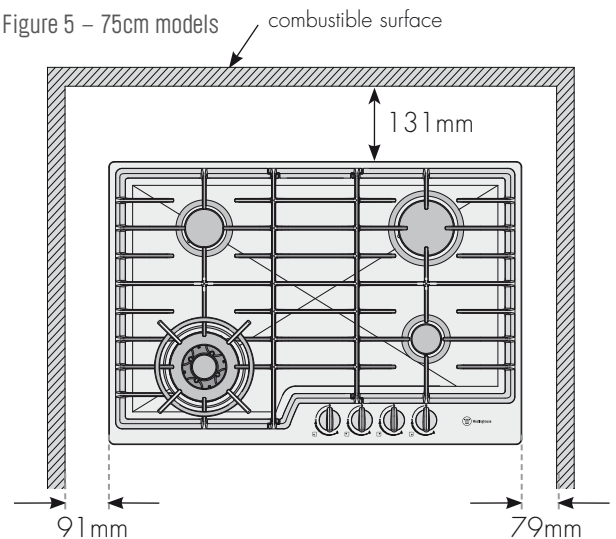
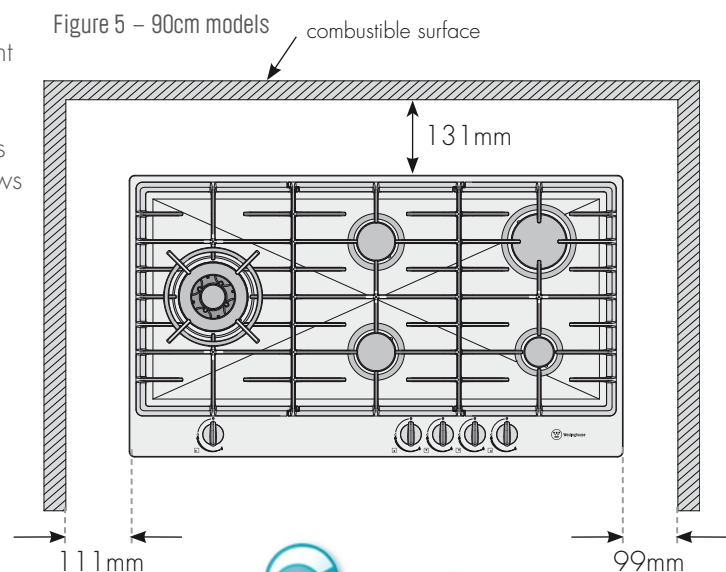

Figure 5 – 90cm models





# INSTALLATION

Figure 6 – 60cm models

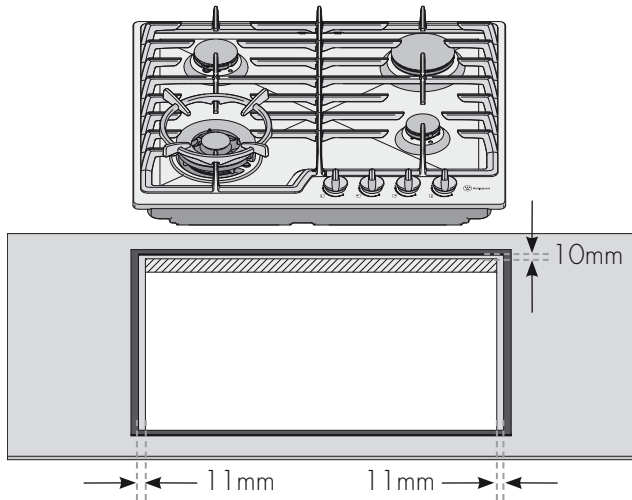

Figure 6 – 75cm models

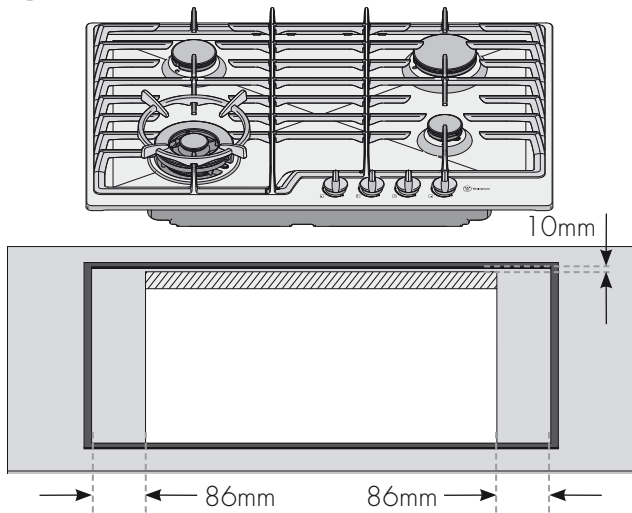

Figure 6 – 90cm models

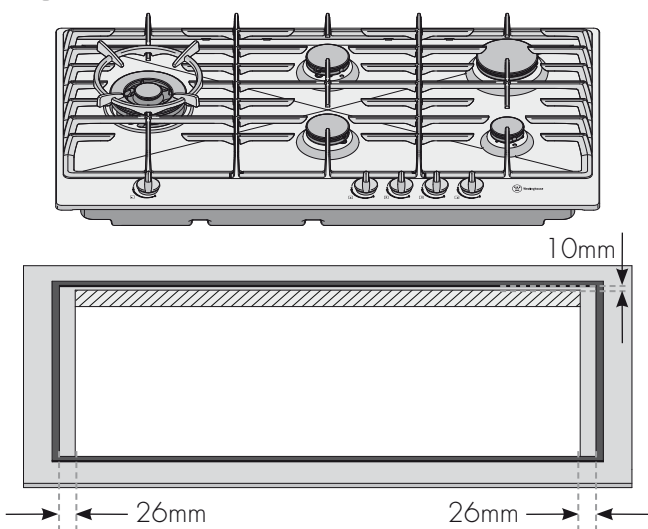

Figure 7

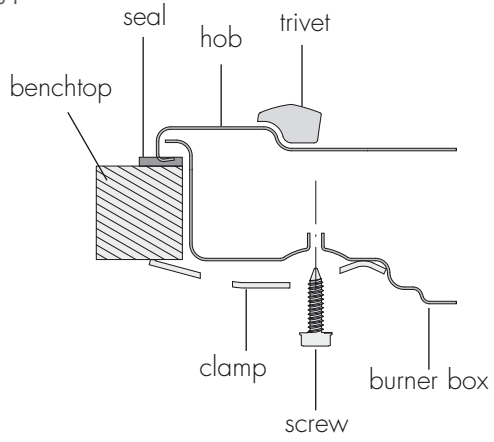

Figure 8 – 60cm and 75cm models

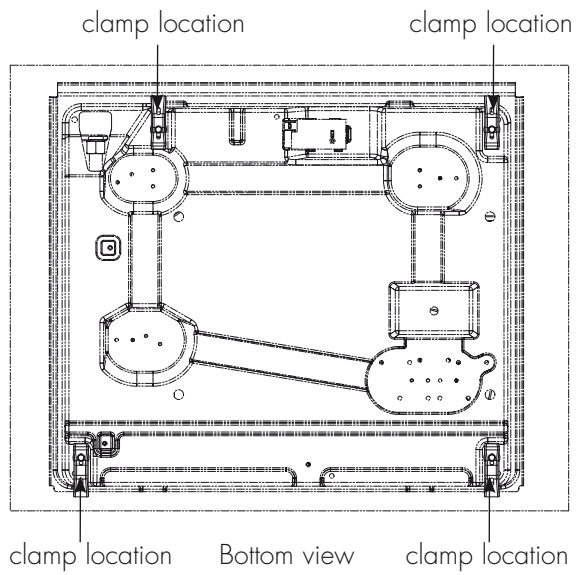
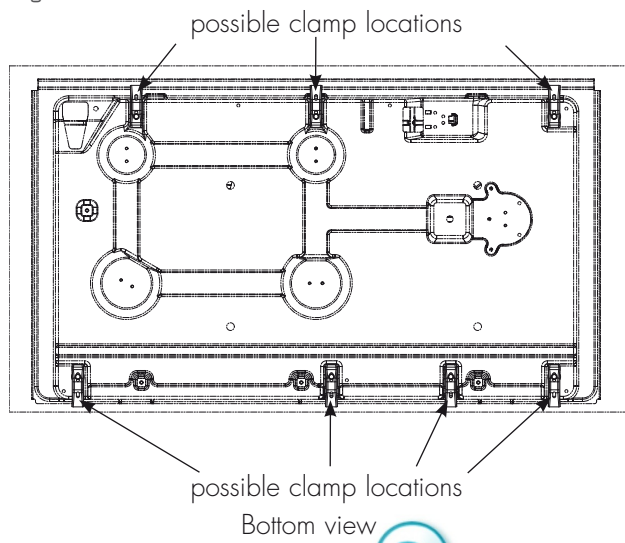

Figure 8 – 90cm models



# GAS CONNECTION

## GAS CONNECTION

This appliance is supplied for use with Natural Gas.

However, it can be converted for use with LPG.

Refer to LP conversion on pages 12 and 13.

### Supply pipe sizing

The total hourly gas consumption for the appliance is shown on the data label. The required supply pressure (i.e. at inlet to appliance regulator) for each gas type is shown on the data label, and given in Table 2.

Use this information in conjunction with the length of run, number of elbows, tees and bends, the available service pressure and the supply requirements of other installed appliances to determine a suitable pipe size. For assistance in this matter refer to the appropriate section of the Installation Code AS5601.

An AGA certified class B or D flexible connection may be used to connect the cooktop in accordance with the AS5601 and in particular section 4.8. Where a hose assembly is used and the cooktop is in the installed position, the hose assembly shall be suitable for connection to a fixed consumer piping outlet located at a point 800 – 850mm above the floor and in the region outside the width of the appliance to a distance of 250mm. The point of connection to consumer piping must be accessible with appliance installed.

### Elbow positioning

It is possible to reposition the elbow if required by loosening the locking nut and elbow by using two spanners. Re-tighten the entire assembly after the elbow has been repositioned. When fitting elbow to appliance, ensure that the sealing washer is fitted.

## OPERATION ON N.G./S.N.G.

### Regulator

An appliance regulator is provided. The regulator must be positioned so that the pressure test nipple is accessible when the appliance is installed. Connect the gas supply to the ½" B.S.P. internal thread inlet of the regulator. Refer to 'bench cutout' (Figure 4) for connection point position.

### Assembly of Regulator

The assembly of the regulator to the cooktop manifold is achieved via the elbow union and sealing washer supplied, refer to figure 9 (page 11).

The ½" parallel thread connects to the manifold, and the sealing washer is placed between the manifold end and the flat face on the elbow.

The ½" tapered thread connects to the outlet of the regulator, and is sealed on the thread using approved thread sealing tape or approved thread sealing compound.

The inlet of the regulator is a ½" parallel thread and is connected to consumer piping or hose assembly.

Regulators are supplied pre-adjusted and configured by the component maker for use with Natural Gas. The appliance installer is not required to make an adjustment to obtain the correct outlet pressure setting.

An arrow on the base of the regulator indicates the direction of gas flow when the inlet and outlet of the regulator is orientated correctly. When the regulator has been fitted check for leaks from the connections with soapy water.

### Checking the gas supply

1. Check the manometer zero point is correct.
2. Connect the manometer to the cooktop pressure point.  
This is located on the regulator.
3. Turn on the gas supply and electricity and try to ignite the gas.

### **i** TIPS & INFORMATION

NOTE! It will take additional time to light the gas for the first time as air needs to be purged from the pipes.

4. With the appliance operating check the outlet pressure
  - when all burners of the appliance are operating at maximum,
  - when the smallest burner of the appliance is operating at minimum.

Under these conditions the outlet pressure should not vary from the nominal outlet pressure of 1.00kPa by more than  $\pm 0.20$ kPa.

If the regulator appears to not be performing satisfactorily, then check the following points.

1. If the outlet pressure is consistently too low then the inlet pressure may be too low and adjustment of an upstream regulator or valve with insufficient flow capacity may be present in the gas supply line. If this is suspected then it may be necessary to repeat the checks whilst measuring both the inlet and outlet pressure to determine if the inlet pressure is in the range 1.13 – 5kPa.
  2. Check that the regulator has been fitted to the gas supply line in the correct orientation, the arrow on the base of the body indicates the direction of gas flow.
- Once these checks have been completed, if the regulator still fails to perform in a satisfactory manner it should be replaced.

Figure 9

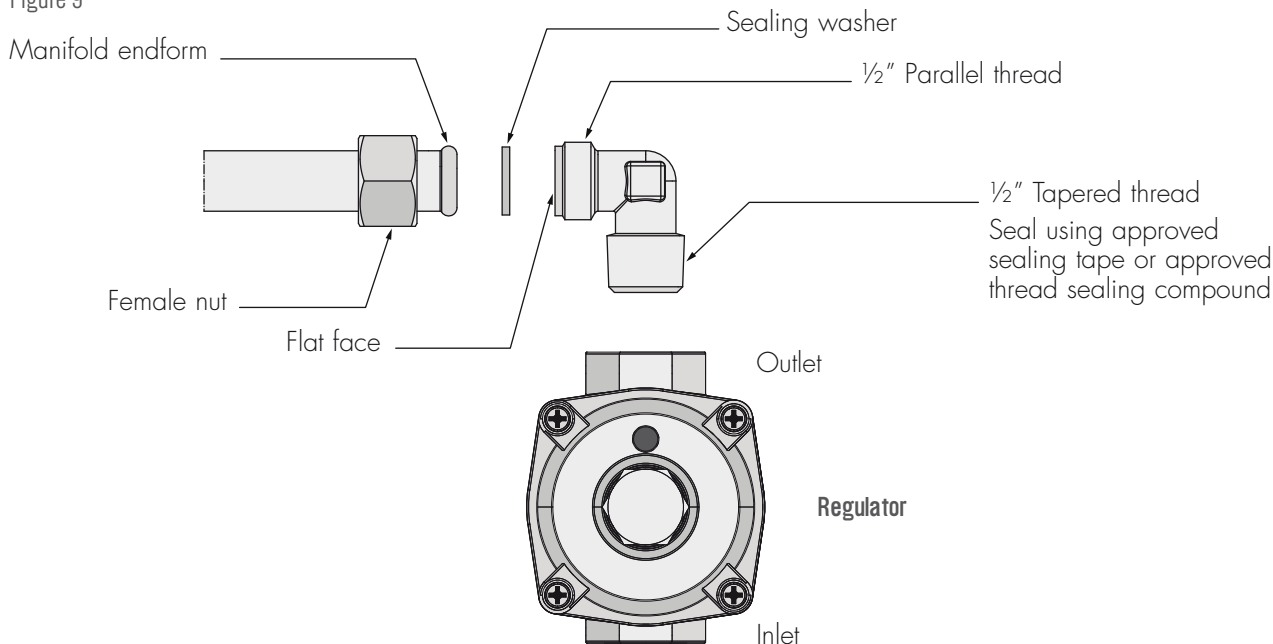

# LPG CONVERSION



## CAUTION

This appliance is fitted with Natural Gas burner injectors. Please follow the procedure below if a conversion to suit LP gas is required.

The conversion kit contains appropriate LPG injectors and 1 LPG sticker.

### To convert to LPG

1. Remove the hotplate burners to access the hotplate injectors. Replace the factory fitted NG injectors with the appropriate injectors, as supplied (see Table 2).
2. Unscrew the hex nut from the regulator. The hex nut, brass washer and nylon insert will disengage as an assembly.
3. Unclip the nylon insert from the nut assembly by rotating the insert  $\frac{1}{4}$  turn, and pulling it free.
4. Turn over the insert, and clip back into position.
5. Refit the hex nut assembly to the regulator ensuring that it is fully screwed down. The regulator is now set for connection to LP.
6. Turn on the gas supply and at each new connection check for leaks using soapy water: each hotplate valve should be turned on, one at a time, and the injector hole blanked off for several seconds.
7. The operation of the regulator can be confirmed by connecting a manometer to the pressure test point located on the side of the regulator body adjacent to the outlet. With the appliance operating check the outlet pressure
  - when all burners of the appliance are operating at maximum,
  - when the smallest burner of the appliance is operating at minimum.

Under these conditions the outlet pressure should not vary from the nominal outlet pressure of 2.60kPa by more than  $\pm 0.52$ kPa.

8. If the regulator appears to not be performing satisfactorily then check the following points.
  - If the outlet pressure is consistently too low then the inlet pressure may be too low and adjustment of an upstream regulator may be needed, or an upstream regulator or valve with insufficient flow capacity may be present in the gas supply line. If this is suspected then it may be necessary to repeat the checks whilst measuring both the inlet and outlet pressure to determine if the inlet pressure is in the range 2.75–7.00kPa.
  - Check that the insert has been fitted correctly as per diagram figure 10. Check that the hex nut is fully screwed down.
  - Check that the regulator has been fitted to the gas supply line in the correct orientation, the arrow on the base of the body indicates the direction of gas flow.Once these checks have been completed, if the regulator still fails to perform in a satisfactory manner it should be replaced.
9. One by one, turn the knobs to minimum and screw in the bypass screw (accessible when the knob is removed – refer figure 12) until a small stable flame results. Turn the knob to maximum and then back to minimum to ensure that the correct minimum flame is maintained.
10. Attach the LPG sticker to the cooker, near the gas supply inlet. Cover the Natural Gas label that is factory fitted.

Table 2

BURNER TYPE	NATURAL GAS (Nominal test point pressure: 1.00kPa)		LPG (Nominal test point pressure: 2.60kPa)	
	Injector size (mm)	Gas consumption (MJ/h)	Injector size (mm)	Gas consumption (MJ/h)
Small burner	1.00	5.1	0.55	4.2
Medium burner	1.35	9.0	0.70	6.5
Large burner	1.60	12.1	0.90	10.7
Wok burner	1.75	14.4	1.00	13.0

Figure 10

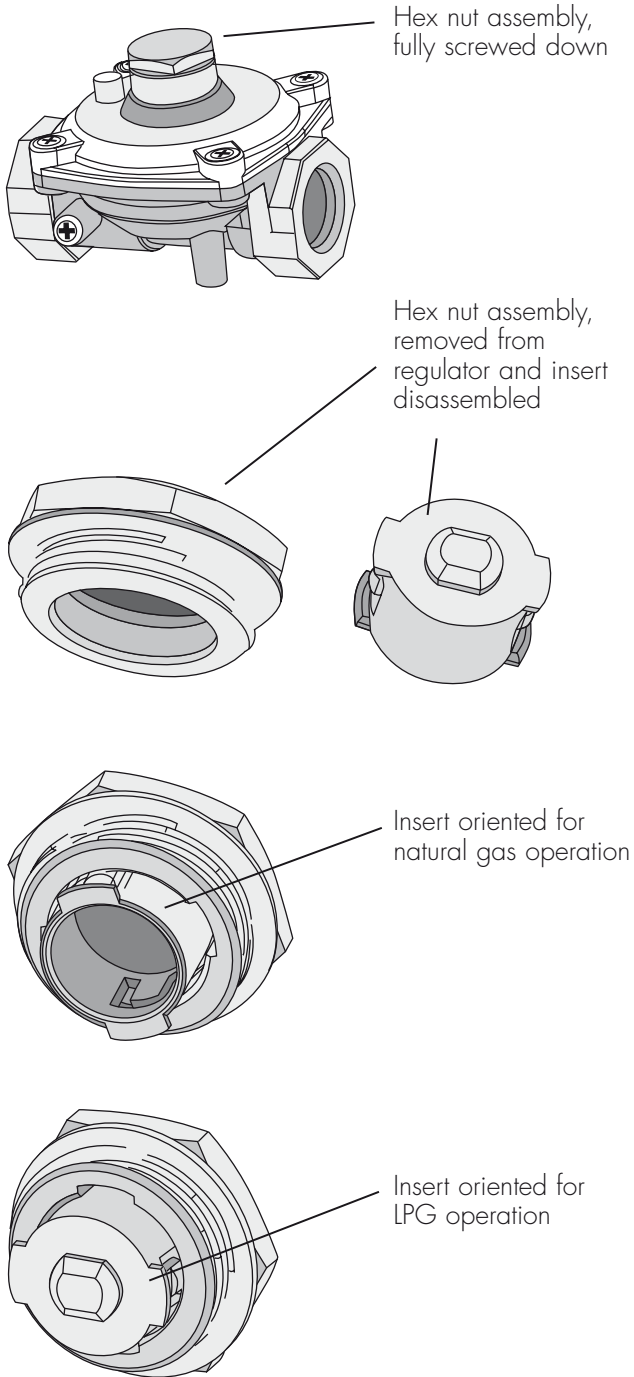

## ELECTRICAL CONNECTION (220-240 volts)

The appliance is supplied with a standard 7.5Amp service cord terminated by a 3-pin plug for connection to a standard household socket. The electrical supply is required to power the electronic ignition system.

**NOTE:** It will be necessary for servicing purposes to disconnect the electrical power supply. The power point should therefore be accessible after the appliance is installed, as specified in the local wiring regulations.

Diagram 1 is a schematic of the wiring in the appliance. The weight of the unit is printed on the appliance packaging label.

Diagram 1

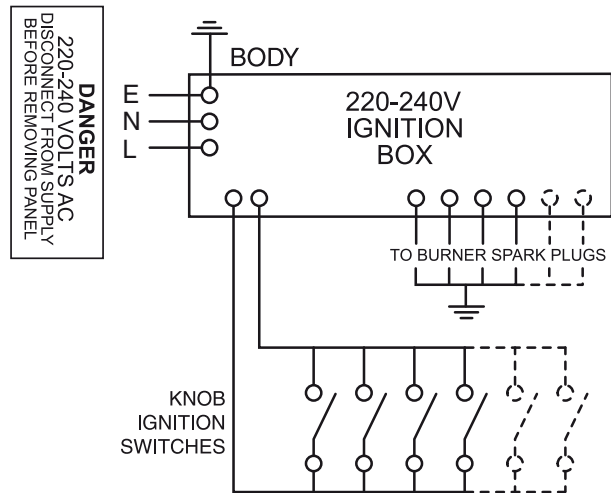

### Use of Hose Assemblies

Ensure that the hose assembly is restrained from accidental contact with the flue outlet of an underbench oven or any other hot surface of an adjacent appliance.

## TESTING APPLIANCE OPERATION

After installation, test the appliance and ensure that it operates correctly before handing it over to the customer. The following procedure is recommended:

1. Turn on the gas and electricity supply and attempt ignition on all burners, both separately and in combination. (For correct procedure, refer to page 4). Note that additional time needs to be allowed for the initial lighting as air has to be purged from the pipes.
2. Observe the flame appearance on each burner. (Figure 11) If it is much larger or much smaller than expected, the injector size and supply pressure require checking. Where a flame is unsatisfactory, refer to the Troubleshooting Guide (Page 6) to correct the fault. If the Troubleshooting Guide does not solve the problem, call the Service Centre.
3. When all the foregoing is satisfactory, check the turndown (minimum or low) setting on each burner, as this may need adjustment. Valves have a bypass controlling screw, which may be accessed by removing the knob. This screw will be located on a particular area of the valve. (Refer figure 12). Normally, this will have been correctly set at the factory for use on NG (Natural Gas) and should not require adjustment. If the appliance has been converted to LPG, then the bypass screw will have to be screwed in until a small, stable flame results.

**Please ensure the supply pressure has been checked PRIOR to any adjustment.**

4. If the appliance cannot be adjusted to perform safely, inform the customer of the problem and affix an appropriate warning notice to the appliance. If the fault appears to be dangerous the appliance should be disconnected. If a minor fault exists, the customer may wish to use the appliance while awaiting service. If a fault cannot be fixed, please call the Service Centre.
5. The customer should be advised that, in the event of a fault, the local Service Organisation or the retailer from whom the appliance was purchased should be contacted.
6. When satisfied that the unit is operating correctly, turn off and instruct the customer on correct operation as outlined in this booklet. Ask the customer to operate the controls to ensure that the correct procedure is understood.

### **WARNING**

Servicing must only be carried out by an authorised service person.

Injector sizes required for various gas types are shown in Table 2 (page 11). The appliance inlet pressure for each gas type is also shown.

For model identification after installation, an additional data plate sticker has been provided. This sticker is to be stuck onto adjacent cabinetry.

Figure 11

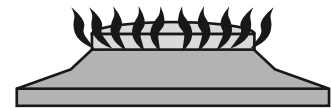

Flame size adjusted to maximum

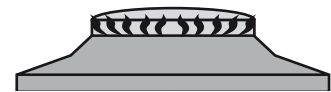

Flame size adjusted to minimum

Figure 12

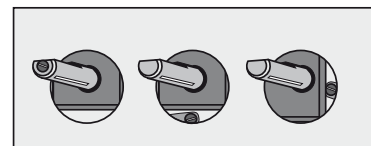

Bypass screw



# Electrolux WARRANTY

FOR SALES IN AUSTRALIA AND NEW ZEALAND  
APPLIANCE: WESTINGHOUSE 4 & 5 BURNER GAS COOKTOPS

This document sets out the terms and conditions of product warranties for Electrolux branded appliances. It is an important document. Please keep it with your proof of purchase documents in a safe place for future reference should you require service for your Electrolux appliance.

## General Terms and Conditions

1. In this warranty
  - (a) 'Electrolux' means Electrolux Home Products Pty Ltd ABN 51 004 762 341 in respect of Appliances purchased in Australia and Electrolux (NZ) Limited in respect of Appliances purchased in New Zealand;
  - (b) 'Appliance' means any Electrolux product purchased by you accompanied by this document;
  - (c) 'Warranty Period' means
    - (i) where you use the Appliance for personal, domestic or household purposes in Australia the period of '24' months and in New Zealand the period of '24' months;
    - (ii) where you use the Appliance for commercial purposes, in Australia the period of '3' months and in New Zealand the period of '3' months, (if the period stated is 0 months you are not covered by this product warranty) following the date of original purchase of the Appliance;
  - (d) 'you' means the purchaser of the Appliance not having purchased the appliance for re-sale, and 'your' has a corresponding meaning.
2. This warranty only applies to Appliances purchased and used in Australia or New Zealand and is in addition to (and does not exclude, restrict, or modify in any way) any non-excludable statutory warranties in Australia or New Zealand.
3. Electrolux warrants that, when dispatched from an Electrolux warehouse, the Appliance is free from defects in materials and workmanship for the Warranty Period.
4. During the Warranty Period Electrolux or its Authorised Service Centre will, at no extra charge if your appliance is readily accessible without special equipment, and subject to these terms and conditions, repair or replace any parts which it considers to be defective. Electrolux or its ASC may use reconditioned parts to repair your appliance. You agree that any replaced Appliances or parts become the property of Electrolux. This warranty does not apply to light globes, batteries, filters or similar perishable parts.
5. Parts and Appliances not supplied by Electrolux are not covered by this warranty.
6. Where you are within an Electrolux service area, this warranty covers the cost of transport of the Appliance to and from Authorised Service Centres of Electrolux and travelling costs for representatives of the Authorised Service Centre to and from your home or business. If you are outside an Electrolux service area, you will bear these costs. For information about whether you are within an Electrolux service area, please phone 13 13 49 in Australia, or 0800 10 66 10 in New Zealand.
7. Proof of purchase is required before you can make a claim under this warranty.
8. You may not make a claim under this warranty unless the defect claimed is due to faulty or defective parts or workmanship. Electrolux is not liable in the following situations (which are not exhaustive):

- (a) The Appliance is damaged by:
    - (i) accident
    - (ii) misuse or abuse, including failure to properly maintain or service
    - (iii) normal wear and tear
    - (iv) power surges, electrical storm damage or incorrect power supply
    - (v) incomplete or improper installation
    - (vi) incorrect, improper or inappropriate operation
    - (vii) insect or vermin infestation.
  - (b) The Appliance is modified without authority from Electrolux in writing.
  - (c) The Appliance's serial number or warranty seal has been removed or defaced.
  - (d) The Appliance was serviced or repaired by anyone other than Electrolux or its Authorised Service Centres.
9. This warranty, the contract to which it relates and the relationship between you and Electrolux are governed by the law applicable in the Australian State where the Appliance was purchased or the law applicable in New Zealand if the Appliance was purchased in New Zealand. Where the Appliance was purchased in New Zealand for business purposes the Consumer Guarantee Act does not apply.

## Limitation of Liability

10. To the extent permitted by law:
    - (a) Electrolux excludes all warranties other than as contained in this document;
    - (b) Electrolux shall not be liable for any loss or damage whether direct or indirect or consequential arising from your purchase, use or non-use of the Appliance.
  11. Provisions of the Trade Practices Act and State consumer legislation in Australia, and the Consumer Guarantees Act, the Sale of Goods Act and the Fair Trading Act in New Zealand, imply warranties or conditions, or impose obligations, upon Electrolux which cannot be excluded, restricted or modified. To the extent permitted by law, the liability of Electrolux (if any) arising out of or in relation to the Appliance or any services supplied by Electrolux shall be limited (where it is fair and reasonable to do so):
    - (a) in the case of Appliances, at its option, to the replacement or repair of the Appliances or the supply of equivalent products or the payment of the cost of replacing the Appliances or having the Appliances repaired or of acquiring equivalent Appliances. Upon being replaced, parts and Appliances become the property of Electrolux; or
    - (b) in the case of services, at its option, to the supply of the services again or the payment of the cost of having the services re-supplied;
- and in the case of Appliances or services supplied in New Zealand, loss or damage whether direct or indirect or consequential that is reasonably foreseeable.

## Privacy

You acknowledge that in the event that you make a warranty claim it will be necessary for Electrolux and its Authorised Service Centres to exchange information in relation to you to enable Electrolux to meet its obligations under this warranty.

## Important Notice

Before Calling a Service Technician please check carefully the operating instructions, service booklet and the warranty terms and conditions.

<p><b>FOR SERVICE</b> or to find the address of your nearest state service centre in Australia <b>PLEASE CALL 13 13 49</b> For the cost of a local call (Australia only)</p>	<p><b>SERVICE AUSTRALIA</b>  ELECTROLUX HOME PRODUCTS www.electrolux.com.au</p>	<p><b>FOR SPARE PARTS</b> or to find the address of your nearest state spare parts centre in Australia <b>PLEASE CALL 13 13 50</b> For the cost of a local call (Australia only)</p>
<p><b>FOR SERVICE</b> or to find the address of your nearest authorised service centre in New Zealand <b>FREE CALL 0800 10 66 10</b> (New Zealand only)</p>	<p><b>SERVICE NEW ZEALAND</b>  ELECTROLUX HOME PRODUCTS www.electrolux.co.nz</p>	<p><b>FOR SPARE PARTS</b> or to find the address of your nearest state spare parts centre in New Zealand <b>FREE CALL 0800 10 66 20</b> (New Zealand only)</p>



**For more information on all Westinghouse appliances,  
or for dimension and installation information, call into your retailer,  
phone or email our customer care team or visit our website:**

#### AUSTRALIA

phone: 1300 363 640  
fax: 1800 350 067  
email: [customercare@electrolux.com.au](mailto:customercare@electrolux.com.au)  
web: [www.westinghouse.com.au](http://www.westinghouse.com.au)

#### NEW ZEALAND

phone: 09 573 2384  
fax: 0800 363 600  
email: [customercare@electrolux.co.nz](mailto:customercare@electrolux.co.nz)  
web: [www.westinghouse.co.nz](http://www.westinghouse.co.nz)



#### TOP SERVICE

Top Service encompasses the after sales service provided by The Electrolux Group to consumers including delivery, home service and spare parts.

**Westinghouse. We are part of the Electrolux family.  
Share more of our thinking at [www.electrolux.com](http://www.electrolux.com)**

© 2008 Electrolux Home Products Pty Ltd ABN 51 004 762 341  
Print code: WMANIGCTUM Issue Date: Jun 08  
Part number: 305 4423 Rev.1



**Westinghouse**