

# USER MANUAL

Bar Fridges with Ice Box,  
All Refrigerators  
and Upright Freezers

## REFRIGERATION

Models: WIM1000, WIM1200, WRM1300, WRM2400,  
WFM0700, WFM0900 & WFM1800



Westinghouse

# CONTENTS

## CONGRATULATIONS

Congratulations and thank you for choosing our refrigerator/freezer. We are sure you will find your new appliance a pleasure to use. Before you use the appliance, we recommend that you read through the relevant sections of this manual, which provides a description of your appliance and its functions.

To avoid the risks that are always present when you use an electric appliance, it is important that the appliance is installed correctly and that you read the safety instructions carefully to avoid misuse and hazards.

We recommend that you keep this instruction booklet for future reference and pass it on to any future owners.

After unpacking the appliance, please check it is not damaged. If in doubt, do not use the appliance but contact your local customer care centre.



### TIPS & INFORMATION

**IMPORTANT – CHECK FOR ANY DAMAGES OR MARKS.** If you find the refrigerator is damaged or marked, you must report it within 7 days if you wish to claim for damage/marks under the manufacturers warranty. This does not affect your statutory rights.



### ENVIRONMENTAL TIPS

#### INFORMATION ON DISPOSAL FOR USERS

- Most of the packing materials are recyclable. Please dispose of those materials through your local recycling depot or by placing them in appropriate collection containers.
- If you wish to discard this product, please contact your local authorities and ask for the correct method of disposal.

## CONTENTS

Important safety instructions . . . . .	3
Bar refrigerator with ice box features . . . . .	4
Bar refrigerator without ice box features . . . . .	5
Single door all refrigerator features . . . . .	6
Bar freezer features . . . . .	7
Single door all freezer features . . . . .	8
Installing your new appliance . . . . .	9
Ventilation around your appliance. . . . .	9
Installing your refrigerator . . . . .	9-10
Initial start-up . . . . .	10
Manual controls . . . . .	10
Controlling the temperature. . . . .	10
Using your appliance – Ice box models. . . . .	11
Making ice . . . . .	11
De-icing the ice box. . . . .	11
Freezer operation . . . . .	12
Reversing the ice box door opening direction . . . . .	13
Reversing the door opening direction WIM1000 & WFM0700 . . . . .	14
Reversing the door opening direction WIM1200, WRM1300, WRM2400, WFM0900 & WFM1800 . . . . .	15
Care and maintenance . . . . .	
Changing the light bulb . . . . .	16
General information . . . . .	17
Cleaning the appliance . . . . .	17
Safety . . . . .	17
Switching off your appliance . . . . .	17
Troubleshooting . . . . .	18
Warranty . . . . .	19

## IMPORTANT SAFETY INSTRUCTIONS

Please read the user manual carefully and store in a handy place for later reference.  
The symbols you will see in this booklet have these meanings:



### WARNING

This symbol indicates information concerning your personal safety



### CAUTION

This symbol indicates information on how to avoid damaging the appliance



### TIPS & INFORMATION

This symbol indicates tips and information about use of the appliance



### ENVIRONMENTAL TIPS

This symbol indicates tips and information about economical and ecological use of the appliance

Meanings of symbols used in this manual are shown below:



This symbol indicates never to do this



This symbol indicates always do this



### WARNING

- If pressurised aerosol containers bear the word 'flammable' and/or a small flame symbol, do not store them inside any refrigerator or freezer. If you do so you may cause an explosion.
- When you dispose of your old refrigerators and freezers, remove any doors. Children can suffocate if they get trapped inside.
- This appliance contains insulation formed with flammable blowing gases. Avoid safety hazards by carefully disposing of this appliance.



### WARNING

- ✓ The refrigerator must be plugged into its own dedicated 220-240V, 50Hz AC electrical outlet.
- ✓ The plug must be accessible when the refrigerator is in position.
- ✓ It is essential the power point is properly earthed to ground. Consult a qualified electrician if you are unsure.
- ✗ Don't use extension cords or adapter plugs with this refrigerator.
- ✓ If the power cord is damaged, have it replaced by a qualified service technician.
- ✓ Unplug the refrigerator before cleaning it, or changing the light bulb to avoid electric shock.
- ✗ Never unplug the refrigerator by pulling the electrical cord as this may damage it. Grip the plug firmly and pull straight out.
- ✓ Choose a location for your refrigerator that isn't too cold. The ambient room temperature should be above 10°C.
- ✓ Stand your refrigerator in a dry place – avoid areas of high moisture or humidity.
- ✗ Don't put the refrigerator in frosty or unprotected areas like a garage or on the verandah.
- ✓ Keep the refrigerator out of direct sunlight.
- ✓ Don't locate the refrigerator near stoves, fires or heaters.
- ✓ When installed correctly, your refrigerator should:
  - Have adequate space at the back and sides for air circulation (refer to page 9).
  - Be aligned to the surrounding cupboards.
  - Have doors that will self-close from a partially open position.



### WARNING

#### R600A REFRIGERANT WARNING

This appliance may contain a small quantity of environmentally friendly, but flammable, non-synthetic R600a refrigerant:

- Ensure that the tubing of the refrigerant circuit is not damaged during transportation and installation.
- The room for installing appliance must be at least 1m<sup>3</sup> per 8g of refrigerant. The amount of refrigerant charged in the appliance can be found on the rating plate on the appliance.
- Keep ventilation openings in the appliance enclosure or in the built-in structure, clear of obstruction.
- Do not use mechanical devices or other means to accelerate the defrosting process, other than those recommended by the manufacturer.
- The room for installing appliance must be at least 1m<sup>3</sup> per 8g of refrigerant. The amount of refrigerant charged in the appliance can be found on the rating plate on the appliance.

# FEATURES

## BAR REFRIGERATORS WITH ICE BOX FEATURES

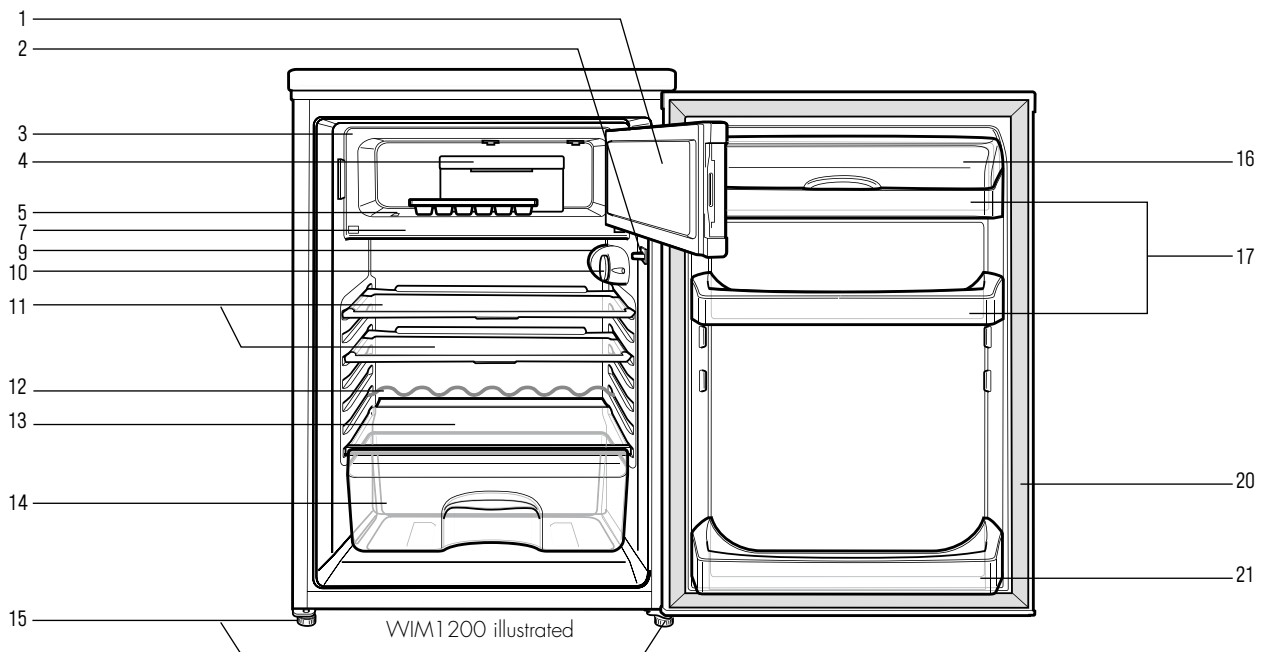
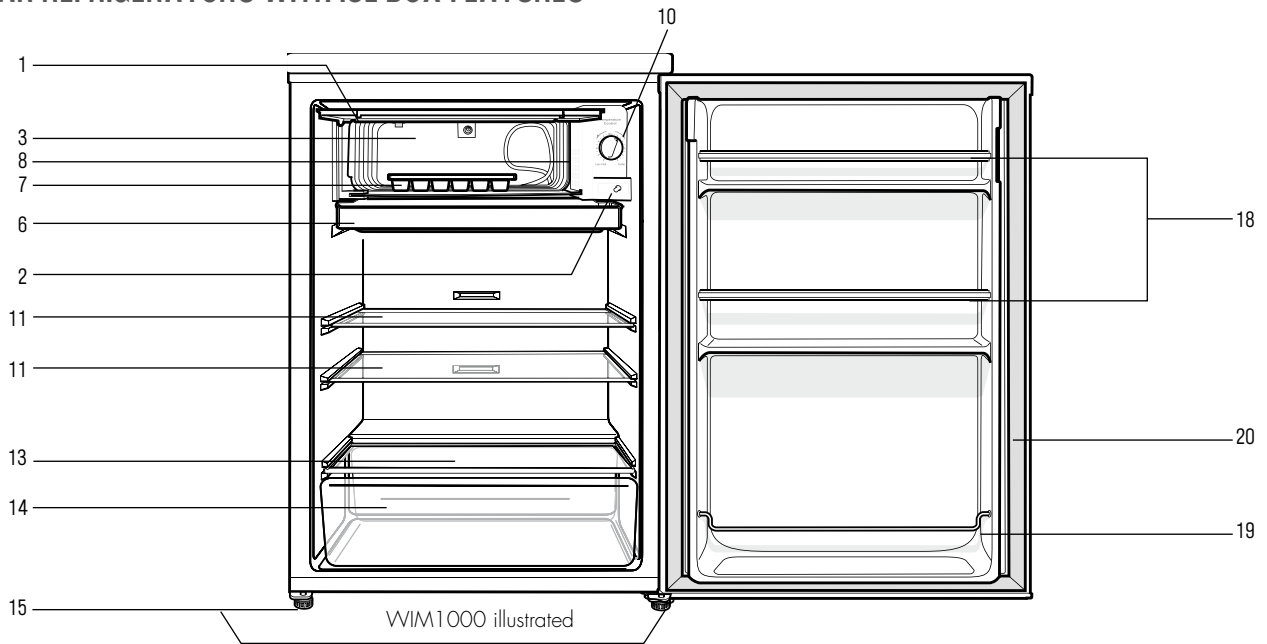

- |                 |                             |                       |
|-----------------|-----------------------------|-----------------------|
| 1 Ice box door  | 9 Light lens                | 17 Door bin           |
| 2 Light switch  | 10 Control knob             | 18 Plastic door strap |
| 3 Ice box       | 11 Glass shelf              | 19 Metal door strap   |
| 4 Ice bin       | 12 Wine rack                | 20 Door gasket/seal   |
| 5 Drain plug    | 13 Glass crisper cover      | 21 Door bin bottom    |
| 6 Drip tray     | 14 Crisper                  |                       |
| 7 Ice tray      | 15 Adjustable levelling leg |                       |
| 8 Light housing | 16 Door bin cover/lid       |                       |

Features may vary depending on model. Not all models will have features listed.

WIM1200SC has grey outer cabinet. Refrigerator door is stainless steel. WIM1200WC has white cabinet and door.

## BAR REFRIGERATORS WITHOUT ICE BOX FEATURES

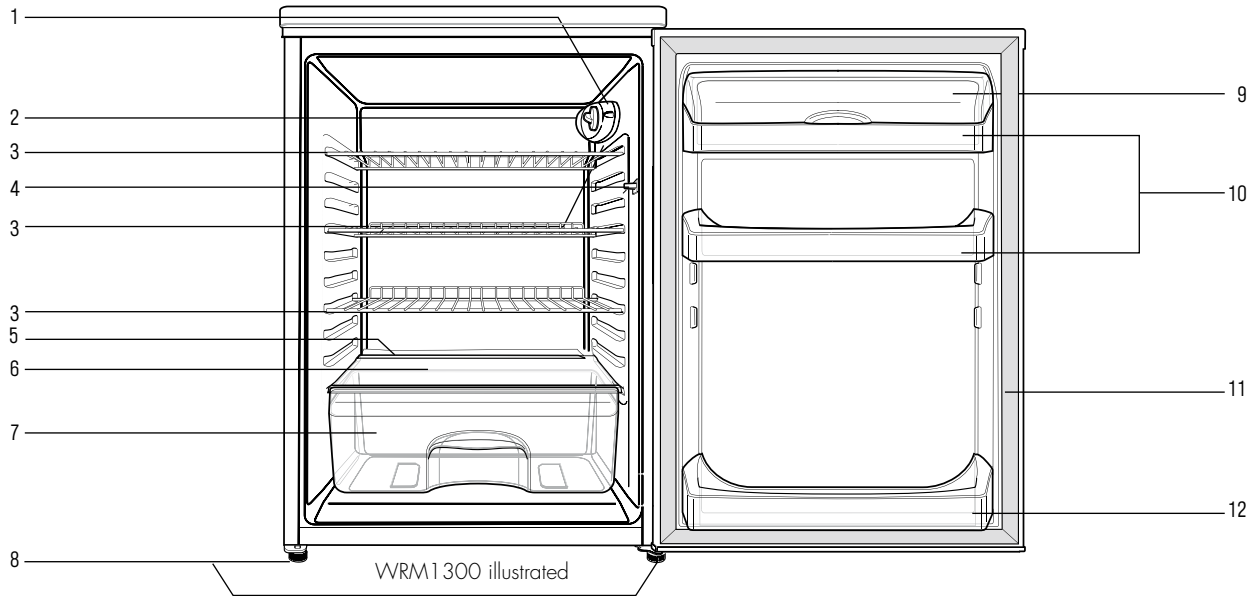

- |                       |                      |
|-----------------------|----------------------|
| 1 Control knob        | 7 Crisper            |
| 2 Light lens          | 8 Levelling leg      |
| 3 Wire shelf          | 9 Door bin cover/lid |
| 4 Light switch        | 10 Door bin          |
| 5 Drain hole          | 11 Door gasket/seal  |
| 6 Glass crisper cover | 12 Door bin bottom   |

Features may vary depending on model. Not all models will have features listed.

# FEATURES

## SINGLE DOOR ALL REFRIGERATOR FEATURES

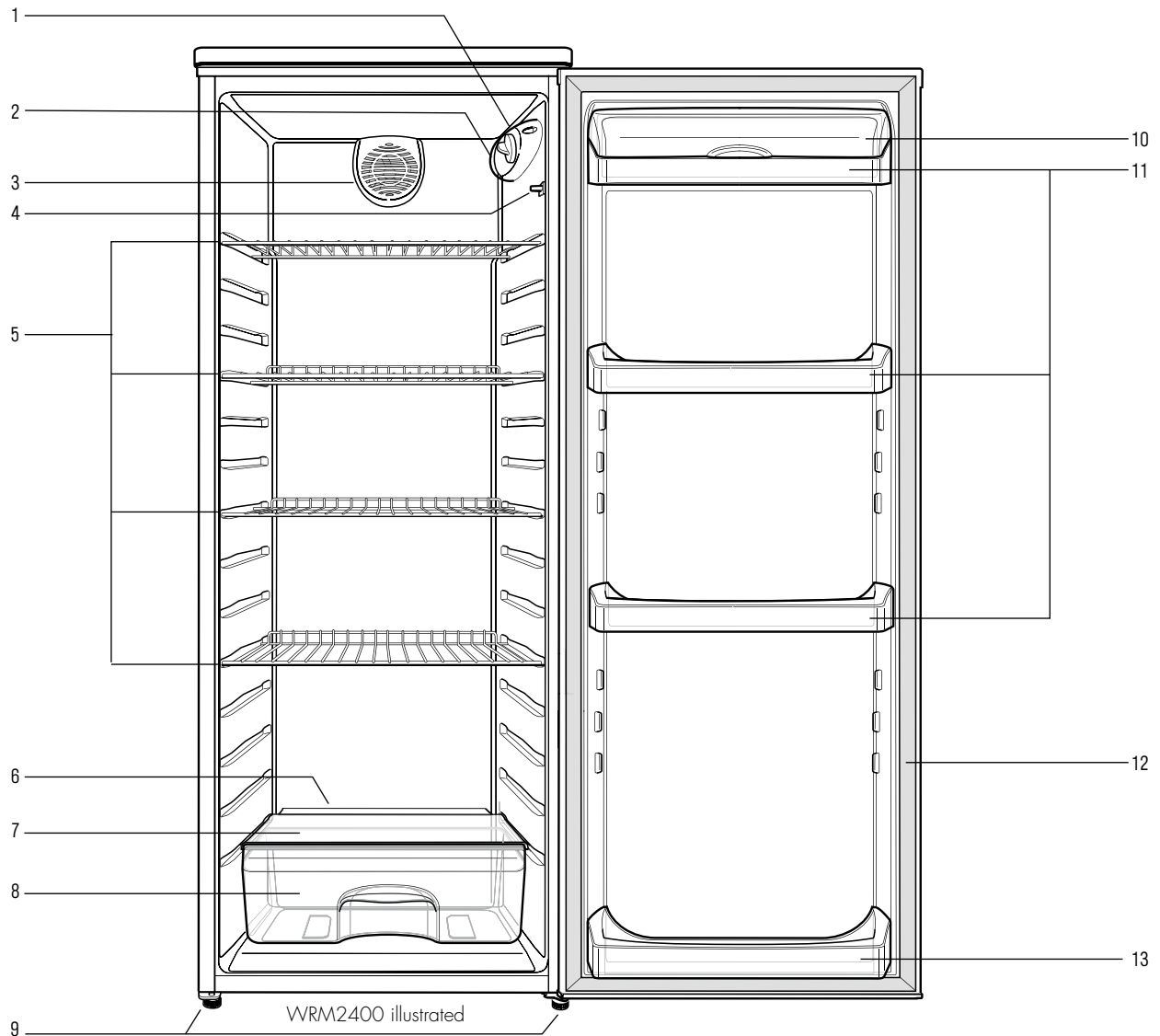

- |                       |                       |
|-----------------------|-----------------------|
| 1 Control knob        | 8 Crisper             |
| 2 Light lens          | 9 Levelling leg       |
| 3 Fan and housing     | 10 Door bin cover/lid |
| 4 Light switch        | 11 Door bin           |
| 5 Wire shelf          | 12 Door gasket/seal   |
| 6 Drain hole          | 13 Door bin bottom    |
| 7 Glass crisper cover |                       |

Features may vary depending on model. Not all models will have features listed.

WRM2400SC has grey outer cabinet. Refrigerator door is stainless steel. WRM2400WC has white cabinet and door.

# BAR FREEZER FEATURES

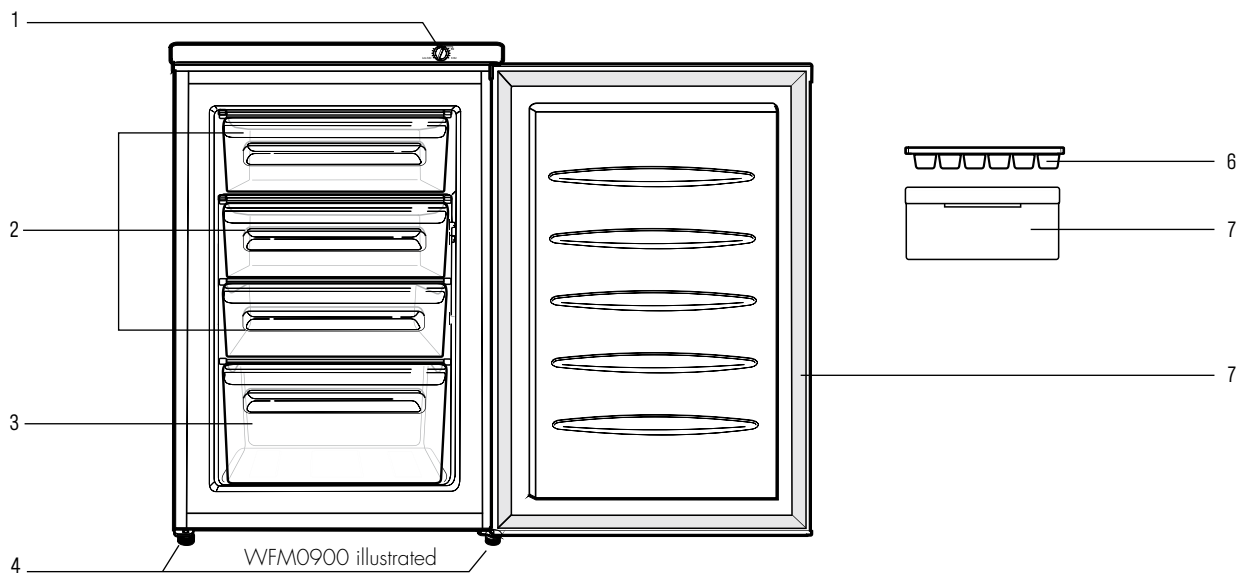
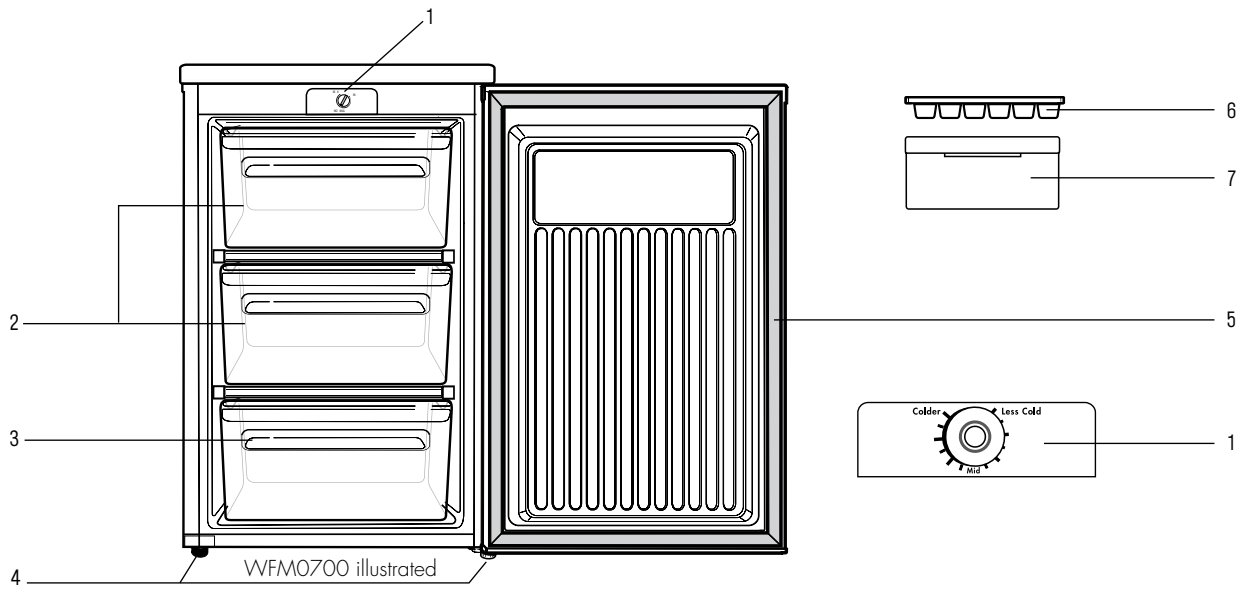

- 1 Temperature control
- 2 Freezer bin
- 3 Bottom freezer bin
- 4 Levelling legs
- 5 Door gasket/seal
- 6 Ice tray
- 7 Ice bin

Features may vary depending on model. Not all models will have features listed.

# FEATURES

## SINGLE DOOR ALL FREEZER FEATURES

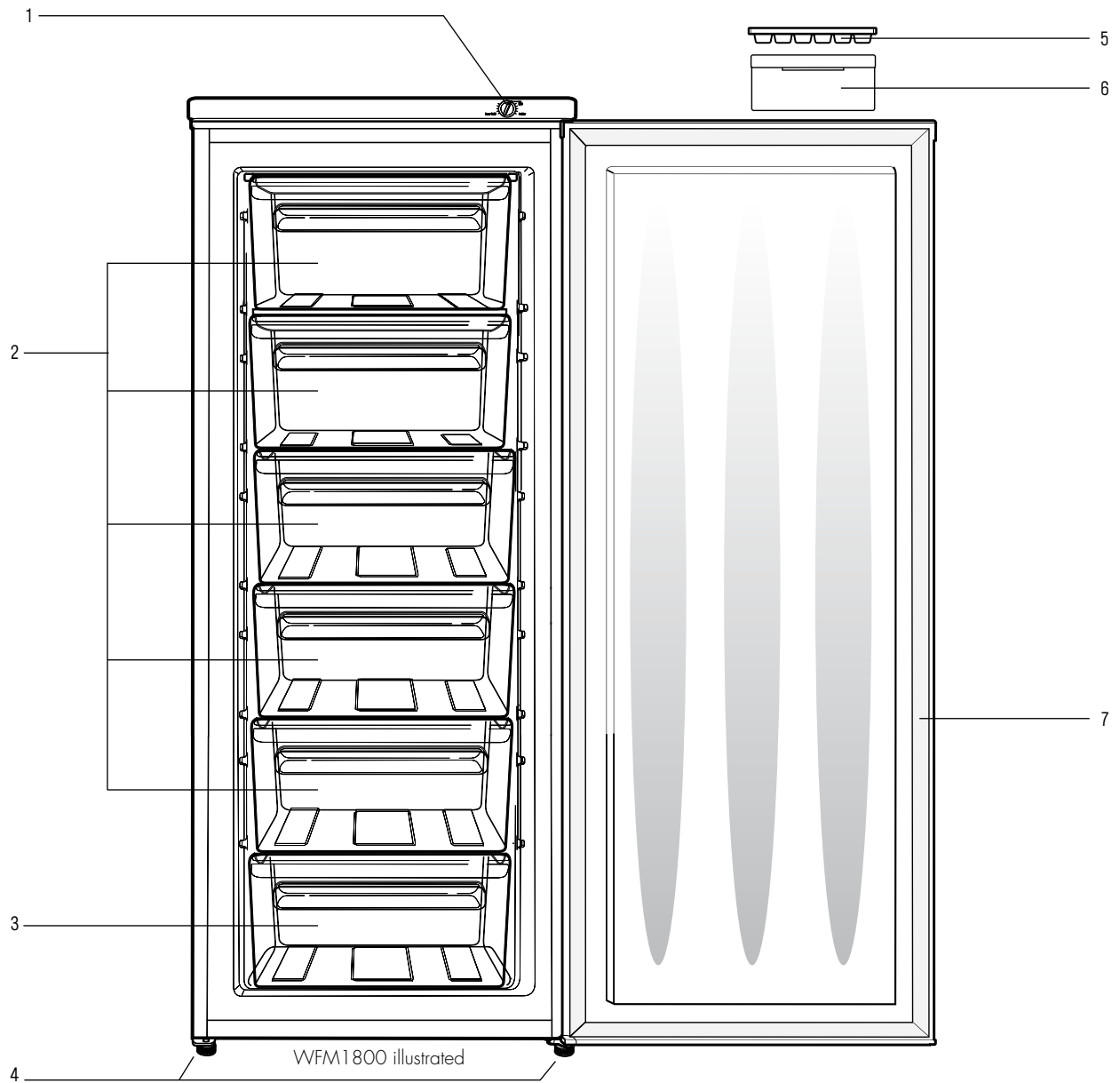

- |   |                    |   |             |
|---|--------------------|---|-------------|
| 1 | Control knob       | 5 | Ice tray    |
| 2 | Freezer bin        | 6 | Ice bin     |
| 3 | Freezer bin bottom | 7 | Door gasket |
| 4 | Levelling leg      |   |             |

Features may vary depending on model. Not all models will have features listed.

WFM1800SC has grey outer cabinet. Refrigerator door is stainless steel. WFM1800WC has white cabinet and door.



## INSTALLING YOUR NEW APPLIANCE

### ADEQUATE VENTILATION AROUND YOUR REFRIGERATOR.

Before you move your appliance into the place where it will operate, check that it will have adequate clearance. Clearance is required for air circulation and too little clearance may affect the performance of your appliance.

We recommend minimum clearances of:

- 30mm on each side.
- 25mm above the refrigerator.
- 50mm minimum/75mm maximum behind the refrigerator

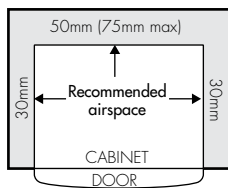

#### NOTE:

Doors are designed to sit proud of cabinetry (not flush). The clearances shown above are the recommended minimum clearances. The clearance at the rear must not exceed 75mm.

### INSTALLING YOUR REFRIGERATOR OR FREEZER

The appliance should arrive with the front levelling feet wound up. The appliance may need to be tilted backward at the top by about 10-15mm from vertical (see diagram below). This will allow the door to gravitate to the closed position. The complete closure of the door seal is reliant on manually pushing the door closed to provide a consistent door seal.

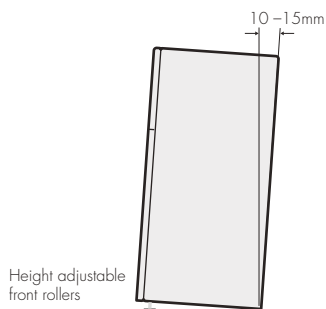

### CAUTION

The rollers are designed for forward or backward movement only. They are not castors. Moving the refrigerator sideways may damage your floor and the rollers.

1. Move the appliance into its final position.
2. If the appliance is not tilting back as described earlier, minor adjustments can be made to the two front levelling legs by turning the feet in an anticlockwise direction (below). This will increase the height of the feet. If you have difficulty turning the foot, have someone tilt the appliance back to gain better access. If it is not tilted back enough and the levelling legs are fully extended, additional packing might be required (see note 4 for appropriate materials).



3. Compare the alignment of the appliance to the surrounding cupboard. The top of the appliance should be level from side to side (see diagram below). If you need to adjust the level, use the levelling feet as detailed in step 2.

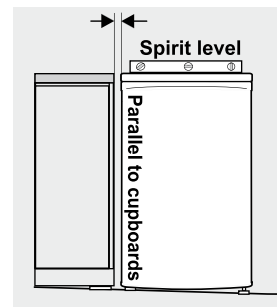

4. If the appliance now rocks from one corner to the opposite rear corner, this means that the floor is uneven. You may need to put some packing under the ridge to the rear of the appliance. You could use thin pieces of solid material such as thin board, vinyl floor tiles or laminate.
5. You may now need to fine tune the installation by repeating steps 2, 3 and 4.
6. Wipe off any dust that has accumulated during shipping and clean following the directions on page 17.
7. Plug the appliance into the power point. Don't use a double adaptor or extension cord.
8. It is recommended that you let the appliance for an hour or two (three hours for a freezer) before you put any food in it. This will confirm that it is operating correctly and make the conditions appropriate for food storage.

Congratulations! You have successfully installed your refrigerator/freezer.

# INITIAL START-UP

## INITIAL START-UP

This series of refrigerators has been fitted with a 'wet wall' evaporator which is positioned behind the rear liner. The rear liner will, at times be wet or appear frosted. This is normal and demonstrates that the refrigerator is functioning correctly. This product is designed to operate on a power supply of 220/240 volts 50Hz. Connect to a separate power point with a correctly earthed three pin socket. Do not use double adaptors.

### CONTROLLING THE TEMPERATURE IN YOUR REFRIGERATOR

Refrigerators work by transferring heat from the food inside to the outside air. This operation makes the back and sides of the refrigerator (particularly at start-up) feel warm – which is normal. Make sure you fully close the refrigerator door after loading or removing food. If the door is left partially open, a heavy frost will coat the inside of the ice box. Ensure shelves are pushed back completely to prevent them holding the door open. If the unit is unplugged, power lost or turned off, you must wait 3 to 5 minutes before restarting the unit. If you attempt to restart the unit before this time delay, the refrigerator will not start. When the thermostat is turned to it's lowest setting and past the point of resistance, the appliance will not operate.



### WARNING

Power is still supplied to the appliance

To make the appliance operate you must turn the knob clockwise.

For all models, 'Less Cold' corresponds to the warmest temperature while 'Colder' the coldest.

The temperatures in the 2 compartments of the refrigerator cannot be adjusted separately (this refers to WIM1000, WIM1200).

When the ambient room temperature is 16°C, a setting of half way between 'Less Cold' and 'Mid' would be appropriate.

When the ambient room temperature is 25°C, a setting of half way between 'Mid' and 'Colder' could be selected.

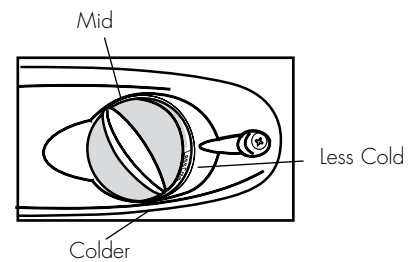

Models WIM1200, WRM1300  
and WRM2400

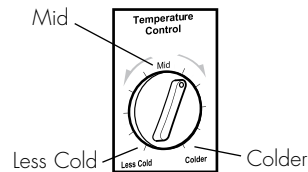

Model WIM1000

When you change temperature settings, make small adjustments and wait 24 hours before assessing whether you need to make further changes.

# ICE BOX MODELS

## ICE BOX MODELS – WIM1000 & WIM1200

The ice box compartment is not a deep freezer and is designed for making ice cubes. It is not recommended for the storage of frozen food.

### ice making

To make ice cubes, fill the ice tray with water and place it in the ice box. To remove ice cubes easily, run water on the tray before gently twisting and inverting the tray.

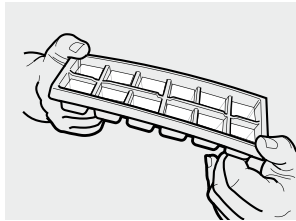

### de-icing

The de-icing system for the fridge compartment is automatic in models WIM1200, and vertical fridges WRM1300 and WRM2400. The rear inside of the fridge is covered with frost when the compressor operates and de-ices when it stops. When the ice melts, the water evaporates automatically. WIM1000 achieves its cooling from the ice box.

### de-icing the ice box

The ice box compartment must always be de-iced when the layer of frost reaches a thickness of about 4mm. This compartment should be de-iced at least once a year regardless of the thickness of the frost. Model WIM1000 has the added feature of a drip tray to collect the water. When de-icing, a scraper or plastic utensil may be used. Never use metal instruments or electrical appliances to de-ice the ice box.

1. Switch off and disconnect the appliance.
2. Remove the plug from the drain (Model WIM1200 – diagram below)

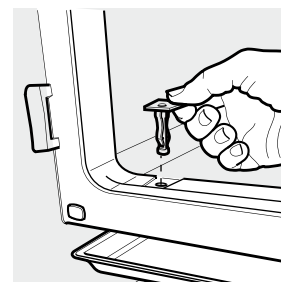

3. Models WIM1200, WRM1300 and WRM2400 have an additional 'Drain Peg' supplied with this user manual. Use the drain peg to ensure the drain hole is not blocked before defrosting (see diagram below). Do not leave the drain peg in the drain hole.



4. Place a container underneath the drain hole to collect the water.
5. To speed up the process, you can place a bowl of hot water inside the compartment and close the door.
6. When de-icing is complete, clean the appliance before restoring the power.

# FREEZER OPERATION

## INITIAL START-UP

Your freezer was cleaned and polished before it left the factory. Before use, dust and wipe over inside and out using a clean dry cloth.

This product is designed to operate on a power supply of 220/240 volts 50Hz. Connect to a separate power point with a correctly earthed three pin socket. Do not use double adaptors.

### GENERAL INFORMATION

The freezer transfers heat from food placed inside to the outside air. This process makes the rear and sides of the outer cabinet feel warm to touch, particularly at initial start up. This is normal.

Make sure you fully close the freezer door after loading or removing food. If the door is left partly open, a heavy frost will coat the inside of the freezer. Ensure that baskets or bins are pushed all the way in to prevent the door being held open.

If the unit is unplugged, power lost, or turned off you must wait 5 minutes before restarting the unit. If you attempt to restart before this time delay, the freezer will not start.

### FEATURES AND GENERAL HINTS

- Try not to leave the door open for too long, especially in warm and humid climates.
- It is recommended that you wrap all food in freezer bags.
- Corned or pickled products (containing salts) must NOT be stored in the freezer unless thoroughly sealed. Salts cause metal oxidation.
- In some circumstances (particularly after recent opening and closing of the door) you may experience a heavier than normal resistance when opening the door. Should this occur wait a minute or two between openings to stabilise the air pressure within the cabinet.
- If going away for an extended period, turn your freezer off, remove all foods and dry interior thoroughly. Unplug the freezer from the electrical outlet and leave the door open.
- If there is a power failure, do not open the door. Frozen foods will stay frozen for up to 24 hours depending on temperature and load conditions if the door is kept closed.
- It is recommended that to ensure safe food storage, the freezer operates for 3 hours with the door closed before being stocked with food. It is also recommended that you wait until the following day before you purchase additional food, either frozen or unfrozen, to stock your freezer.



### WARNING

Do not touch freezer shelf surfaces, particularly when hands are damp or wet. Extremely low temperatures may cause your hands to stick.

### CONTROLS

The temperature control is located on top of the front right hand side of the cabinet on Models WFM0900 and WFM1800. On Model WFM0700, the control knob is on the back of the cabinet in the lower left corner.

Leave the control knob in the 'Mid' position for a trial period. The control setting can be adjusted if required by rotating the knob. Turn in a clockwise direction for a colder temperature. When the thermostat is turned to its lowest setting and past the point of resistance, the appliance will not operate.

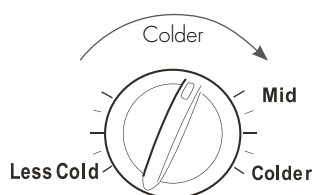

Models WFM0900 & WFM1800

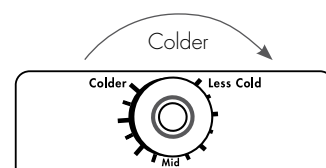

Model WFM0700

### DEFROSTING

Your freezer should be defrosted when frost is approximately 6mm thick otherwise it will interfere with efficient operation and storage capacity. To ensure optimal hygiene and efficiency complete defrosting is recommended at least twice a year, preferably when food supply is low.

- Switch off power to freezer at power outlet and remove power supply plug from electrical outlet.
- Remove frozen food, wrap in newspaper and place in a cardboard box or esky.
- Leave door open and wait for the frost to soften. Pans of hot water may be placed inside the freezer to speed up the defrosting process.
- Place towels and a container to catch the water in the bottom of the freezer.



### WARNING

On no account should an electric heater or hair dryer be used for defrosting the freezer.



### CAUTION

Do not use a knife, metal scraper or sharp pointed tool or instrument to remove ice as they may cause damage to the lining of your freezer.

- Scrape the softened frost off the walls of your freezer using a plastic scraper.
- After defrosting is complete and all of the water has drained, wipe the freezer thoroughly with a damp cloth before drying thoroughly.
- Reconnect the power cord to the electrical outlet and switch on.
- Replace frozen food.

## REVERSING ICE BOX DOOR OPENING DIRECTION – MODEL WIM1200 ONLY

If the position your fridge occupies would be better suited to a reverse opening arrangement, carefully follow these diagrams and instructions. The reversing of doors or replacement of light bulbs is not covered by warranty. Assistance, if required can be arranged by calling our service centre on 13 13 49. Normal service call and labour charges apply.

### PRECAUTIONS

- Turn off the appliance
- Unplug the power cable

Push a flat bladed screwdriver up into the slot at the angle illustrated to release the plastic pin securing the ice box door. At the same time, pull the ice box door forward to release both the door and the pin from the ice box.

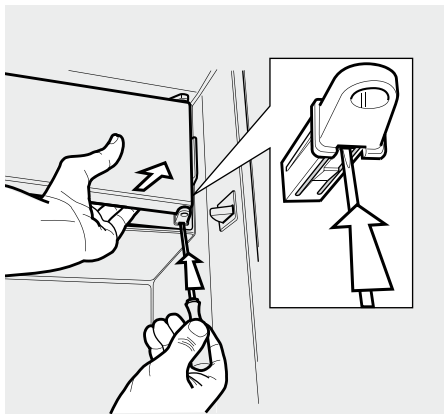

Rotate the door for reverse opening.

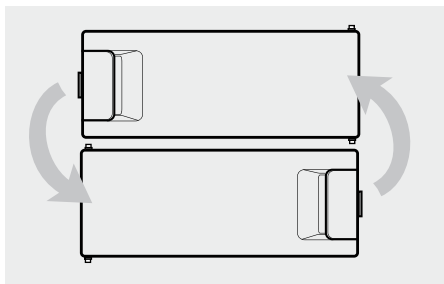

Remove plug to open shaft for pin to go in.

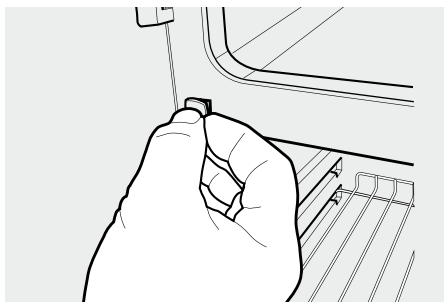

Insert plug into the empty pin cavity on the other side.

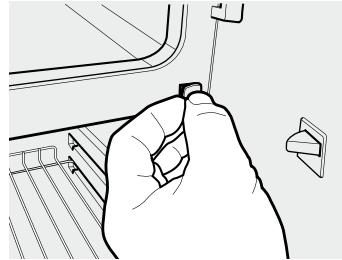

Insert the node on the top of the door into the hinging hole in the top of the fridge liner.

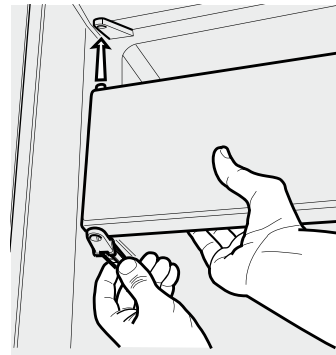

With the plastic pin pushed onto the bottom node on the ice box door and held in place, push the pin into the hole on the ice box frame until the clasp on the pin locks it into position.

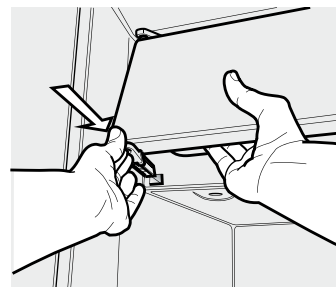

# DOOR REVERSAL

## REVERSING THE DOOR OPENING DIRECTION WIM1000 & WFM0700

In these examples the operation is changed from right side hinging to left side hinging.

### PRECAUTIONS

- Turn off the appliance
- Unplug the power cable
- Remove all food from the appliance
- Remove shelves and baskets
- Do not lay the appliance down flat on its back as this will impair its operation.
- When tilting the appliance to access the underside, support it so that it will not fall to the floor.

- Support the door from below and remove the two screws (1) that secure the hinge (2) to the bottom right side of the appliance. Stand the door to one side carefully.
- Unscrew the left front leg (3) and transfer it to the right side.
- Remove the metal hinging pin (6) and the spring (5) beneath it from the hole in the top right hand corner of the door.
- Insert the spring (5) first and then the pin (6) – previously removed from the right hand side – into the top left hole.
- Position the door on the cabinet with the pin (6) protruding from the top left corner entering the corresponding hole (arrowed in left hinging assembly illustration) under the top frame of the cabinet.
- While holding the door in the closed position, secure the hinge (2) – previously removed from the other side – onto the bottom left corner, tightening the 2 screws (1) firmly.

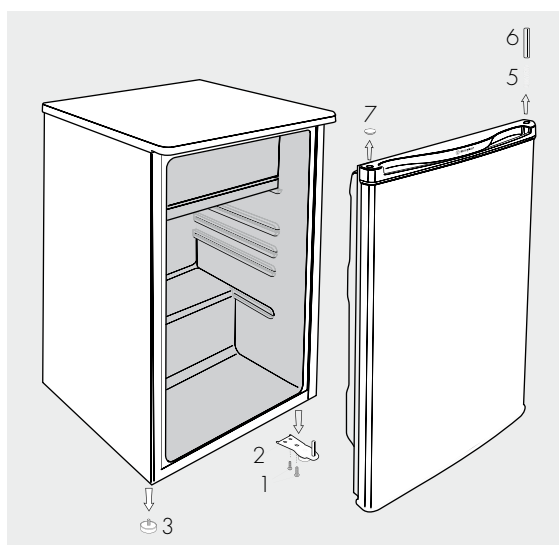

Right sided hinging assembly

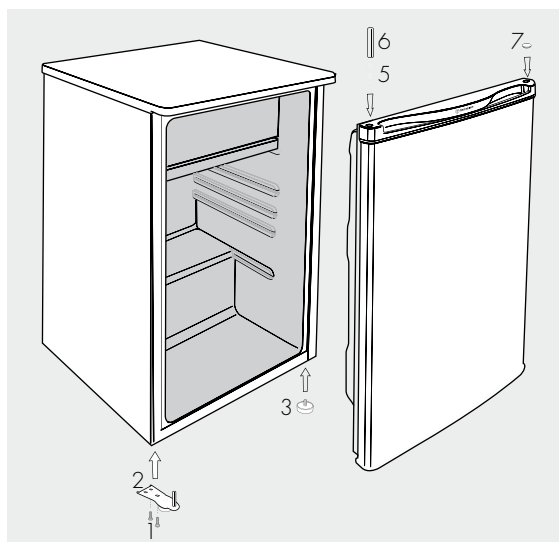

Left sided hinging assembly

Note: All parts removed must be retained to reinstall door.

# DOOR REVERSAL

## REVERSING THE DOOR OPENING DIRECTION WIM1200, WRM1300, WRM2400, WFM0900 & WFM1800

In these examples the operation is changed from right side hinging to left side hinging.

### PRECAUTIONS

- Turn off the appliance
- Unplug the power cable
- Remove all food from the appliance
- Remove shelves and baskets
- Do not lay the appliance down flat on its back as this will impair its operation.
- When tilting the appliance to access the underside, support it so that it will not fall to the floor.

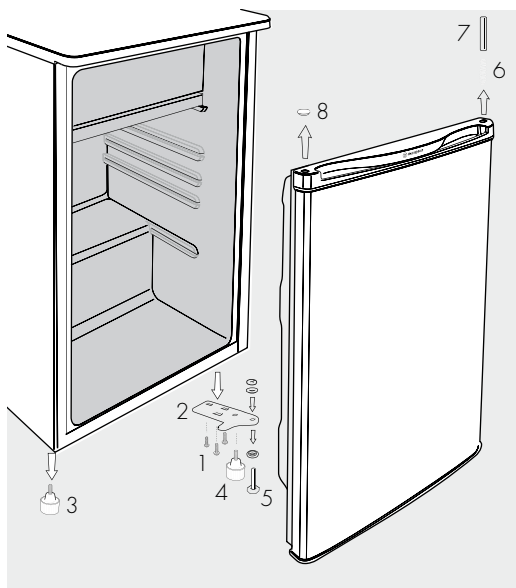

Left sided hinging assembly

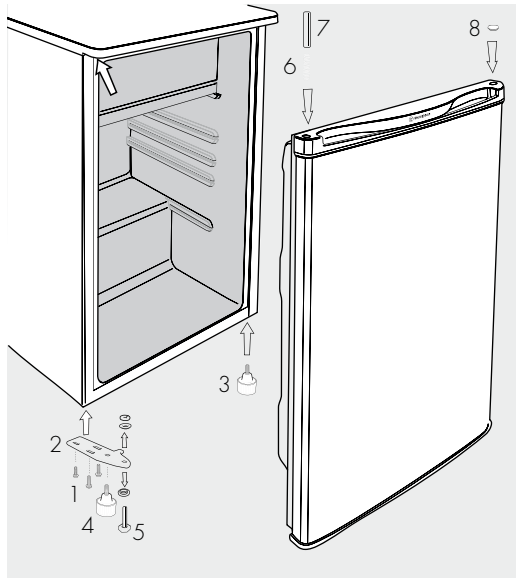

Right sided hinging assembly

- Support the door from below and remove the two screws (1) that secure the hinge (2) to the bottom right side of the appliance. Stand the door to one side carefully.
- Unscrew the left front leg (3) and transfer it to the right side.
- Remove the levelling foot (4) and the bottom hinge pin (5) from the hinge (2), turn the hinge (2) over and screw the levelling foot (4) into the other side of the hinge.
- Remove the metal hinging pin (7) and the spring (6) beneath it from the hole in the top right hand corner of the door.
- Remove the plug (8) – if supplied with your appliance – from the hole in the top left of the door and press firmly into the hole on the top right.
- Insert the spring (6) first and then the pin (7) – previously removed from the right hand side – into the hole in the top left of the door.
- Position the door on the cabinet with the pin (7) protruding from the top left corner entering the corresponding hole (arrowed in left hinging assembly illustration) under the top frame of the cabinet.
- While holding the door in the closed position, secure the hinge (2) – previously removed from the other side – onto the bottom left corner, tightening the 3 screws (1) firmly.

Note: All parts removed must be retained to reinstall door.

# LAMP REPLACEMENT

## LAMP REPLACEMENT FOR MODELS WIM1200, WRM1300, WRM2400

The reversing of doors or replacement of light bulbs is not covered by warranty. Assistance, if required can be arranged by calling our service centre on 13 13 49. Normal service call and labour charges apply.

1. Switch off the power at the power point and remove the cord by pulling the plug.
2. Remove the screw from the centre of the control panel.

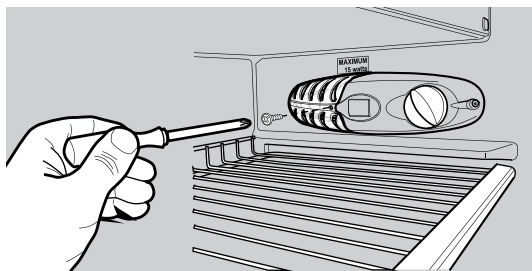

3. Remove the light lens by pushing back and down on the clear plastic tab protruding from the bottom of the lens.

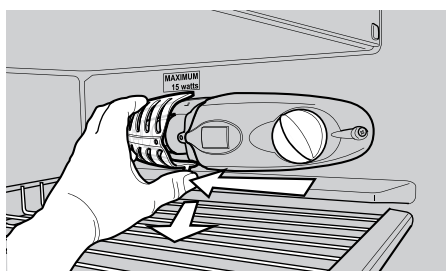

4. Unscrew the spent light bulb in an anti-clockwise direction.

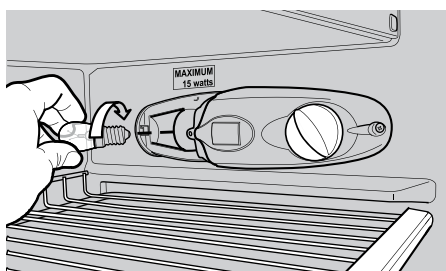

5. Screw the replacement bulb into the socket in a clockwise direction.
6. Replace the light lens and screw.
7. Wait 5 minutes to ensure pressures in the refrigeration system are equalised, before turning the refrigerator on at the power point.

### **WARNING**

Never insert your finger into the light bulb socket.

## LAMP REPLACEMENT FOR MODEL WIM1000

1. Switch off the power at the power point and remove the cord by pulling the plug.
2. Slide out the drip tray from beneath the ice box.

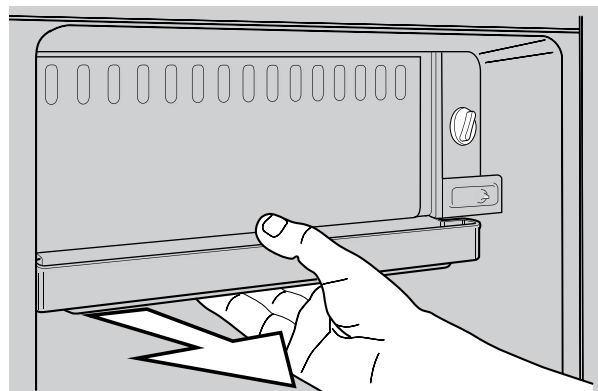

3. Unscrew the light bulb in an anti-clockwise direction.
4. Screw the replacement bulb into the socket in a clockwise direction.
6. Replace the drip tray.
7. Wait 5 minutes to ensure pressures in the refrigeration system are equalised, before turning the refrigerator on at the power point.

### **WARNING**

Never insert your finger into the light bulb socket.

### **TIPS & INFORMATION**

Not all 15 watt screw-in lamps will fit the lamp housing. Appropriate replacement lamps can be purchased from Electrolux or by calling 13 13 50.



# GENERAL INFORMATION

## GENERAL INFORMATION

### CLEANING THE REFRIGERATOR

#### **WARNING**

**BEFORE CLEANING:** Turn the refrigerator off at the power point and unplug the cord to prevent any chance of electrocuting yourself.

- **Doors and exterior (white & pacific silver)**  
You should only clean the doors with lukewarm soapy water and a soft cloth.
- **Stainless Steel**  
Your stainless steel refrigerator is manufactured from mark-resistant stainless steel. This stainless steel has a special advanced protective coating that eases the removal of marks such as fingerprints and water spots. To keep its appearance, clean it regularly with lukewarm soapy water and a soft cloth.

#### **CAUTION**

Never use stainless steel cleaners, abrasive pads or other cleaners that will scratch the surface. Damage to the appliance after delivery is not covered by your warranty.

- **Interior**  
Clean the inside of your refrigerator regularly with a soft cloth, unscented mild soap and lukewarm water. Thoroughly dry all surfaces and removable parts and avoid getting water on the controls. Replace removable parts, plug power cord in and switch the power on before returning the food.
- **Door seals**  
Always keep door seals clean by washing them with a mild detergent and warm water, followed by a thorough drying. Sticky food and drink can cause seals to stick to the cabinet and tear when you open the door.

#### **CAUTION**

Never use hot water, solvents, commercial kitchen cleaners, aerosol cleaners, metal polishes, caustic or abrasive cleaners, or scourers to clean your refrigerator. Many commercially available cleaning products and detergents contain solvents that will damage your refrigerator. Use only a soft cloth with an unscented mild soap and lukewarm water. If your refrigerator has telescopic extension slides, simply wipe them with a damp cloth to clean them and never immerse them in water.

### SAFETY

This appliance is not intended for use by persons (including children) with reduced physical, sensory or mental capabilities, or lack of experience and knowledge, unless they have been given supervision or instruction concerning use of the appliance by a person responsible for their safety. Children should be supervised to ensure that they do not play with the appliance.

### ALWAYS DO THIS

- ⓘ Check the power point is properly earthed – if you are not sure get an electrician to check it.
- ⓘ Switch off and unplug the refrigerator at the power point before you clean or move it.
- ⓘ If the power supply cord is damaged, have it replaced by the manufacturer, service agent or similarly qualified person.

### NEVER DO THIS

- ⓧ Never let children play with the refrigerator.
- ⓧ Never store spray cans, explosive fluids or flammable liquids in the refrigerator.
- ⓧ Never store fizzy drinks in the freezer compartment.
- ⓧ Never lick icy foods when they first come out of the freezer. This can burn your lips and mouth.
- ⓧ Never try to repair the refrigerator yourself.
- ⓧ Never use electric heaters or dryers to defrost the freezer because you can receive an electric shock.
- ⓧ Never use electrical appliances inside the food storage areas.
- ⓧ This appliance contains insulation formed with flammable blowing gases. For safety reasons, take care when you dispose of it.
- ⓧ Do not damage the appliance circuit.

#### **WARNING**

When you dispose of your old refrigerator or freezer, remove any doors to prevent children from being trapped inside.

#### **WARNING**

##### R600A REFRIGERANT WARNING

This appliance may contain a small quantity of environmentally friendly, but flammable, non-synthetic R600a refrigerant:

- Ensure that the tubing of the refrigerant circuit is not damaged during transportation and installation.
- The room for installing appliance must be at least 1m<sup>3</sup> per 8g of refrigerant. The amount of refrigerant charged in the appliance can be found on the rating plate on the appliance.
- Keep ventilation openings in the appliance enclosure or in the built-in structure, clear of obstruction.
- Do not use mechanical devices or other means to accelerate the defrosting process, other than those recommended by the manufacturer.
- The room for installing appliance must be at least 1m<sup>3</sup> per 8g of refrigerant. The amount of refrigerant charged in the appliance can be found on the rating plate on the appliance.

### SWITCHING OFF YOUR REFRIGERATOR

If you switch your refrigerator for an extended period, follow these steps to reduce the chances of mould:

1. Remove all food.
2. Remove the power plug from the power point.
3. Thoroughly clean and dry the Interior.
4. Ensure that all the doors are wedged open slightly for air circulation.

# TROUBLESHOOTING

## WHAT TO DO BEFORE CALLING FOR SERVICE

PROBLEM	SOLUTION
Refrigerator is not operating	<ul style="list-style-type: none"> <li>• Check that the power cord is plugged into the power outlet properly and that the outlet is switched 'ON'.</li> <li>• Try running another appliance from the power outlet. If no power is coming from the outlet you may have blown a fuse or tripped a circuit of your household power supply.</li> <li>• Try adjusting the temperature control to a slightly "colder" position.</li> <li>• It is normal for the freezer fan NOT to operate during the automatic defrost cycle, or for a short time after the appliance is switched on.</li> </ul>
When there is refrigerator/freezer noise	<p>Modern refrigerators/freezers with increased storage capacity use high speed compressors. These can provide a seemingly high level of sound which is quite normal. Normal operational sounds include:</p> <ul style="list-style-type: none"> <li>• Occasional gurgling, similar to water boiling.</li> <li>• Air flow noise (air circulates because of a small fan).</li> <li>• A popping noise heard during automatic defrost.</li> <li>• A clicking noise heard just before the compressor starts (this is just the automatic switching action of the temperature control, turning the compressor on or off).</li> </ul> <p>Other strange sounds may mean that you need to check and take action. For example, noises may mean that:</p> <ul style="list-style-type: none"> <li>• The cabinet is not level.</li> <li>• The floor is uneven or weak.</li> <li>• Bottles are badly placed and rattling.</li> <li>• There are vibrations from an object on top of or behind or beside the refrigerator.</li> <li>• The back of the refrigerator cabinet is touching the wall.</li> </ul> <p>Remember it is quite normal for noise to seem louder just after the refrigerator starts operating.</p>
If there are odours inside the refrigerator	<ul style="list-style-type: none"> <li>• The interior may need cleaning.</li> <li>• Some foods produce odours.</li> <li>• Some containers and wrapping can cause odours.</li> <li>• Ask yourself if the odour started about the same time you started storing something unusual.</li> </ul>

PROBLEM	SOLUTION
When the motor seems to run more than expected	<p>It is normal to frequently hear the sound of the motor. However, to keep operation to a minimum check the following:</p> <ul style="list-style-type: none"> <li>• Are doors kept open too long or too often?</li> <li>• Are controls set too cold? See 'Controls' on page 12.</li> <li>• Have large amounts of warm food just recently been stored? Summer, festive seasons and holidays usually mean a lot more work for your refrigerator.</li> </ul> <ul style="list-style-type: none"> <li>• If the day is hot or the room is very warm, the refrigerator will need to run more than normal.</li> <li>• The refrigerator will run more than normal just after you install it or when it has been turned off for a long time.</li> </ul>
If the temperature in the refrigerator is too warm	<ul style="list-style-type: none"> <li>• Check that the appliance has enough clearance at the sides, back and top. Refer to the installation instructions on page 8.</li> <li>• Refer to 'Controls' on page 12.</li> <li>• You may have kept the door open too long or too frequently.</li> <li>• Food containers or packaging may be holding a door open.</li> </ul>
If the temperature in the refrigerator is too cold	<ul style="list-style-type: none"> <li>• Refer to 'Controls' on page 12.</li> <li>• Increase the temperature to avoid high energy consumption.</li> </ul>
If heavy frosting occurs in the freezer	<p>Make sure you fully close the freezer and fridge doors. If the doors are left open, a heavy frost will coat the inside of the freezer. If a frost develops, remove it and take care to properly close the doors.</p>
If water drips on the floor	<p>The defrost water tray, (located at the back or underneath of the cabinet) may not be properly positioned, or the drain tube may not be properly positioned to direct water into this tray. You may need to pull the refrigerator away from the wall to check the tray and tube.</p>

### IF YOU STILL REQUIRE SERVICE

If you have a problem, and the problem persists after you have made the checks mentioned above, contact your nearest approved Service Centre or the dealer you bought the refrigerator from. Be ready to quote the model number, 9-digit PNC and 8-digit serial number, which is stated on the label inside the refrigerator compartment.

# Electrolux Warranty

FOR SALES IN AUSTRALIA AND NEW ZEALAND

APPLIANCE: WESTINGHOUSE BAR FRIDGES WITH ICE BOX, ALL REFRIGERATORS AND UPRIGHT FREEZERS.

**This document sets out the terms and conditions of product warranties for Electrolux branded appliances. It is an important document. Please keep it with your proof of purchase documents in a safe place for future reference should you require service for your Electrolux appliance.**

## General Terms and Conditions

1. In this warranty
  - (a) 'Electrolux' means Electrolux Home Products Pty Ltd ABN 51 004 762 341 in respect of Appliances purchased in Australia and Electrolux (NZ) Limited in respect of Appliances purchased in New Zealand;
  - (b) 'Appliance' means any Electrolux product purchased by you accompanied by this document;
  - (c) 'Warranty Period' means
    - (i) where you use the Appliance for personal, domestic or household purposes in Australia the period of '24' months and in New Zealand the period of '24' months;
    - (ii) where you use the Appliance for commercial purposes, in Australia the period of '3' months and in New Zealand the period of '3' months, (if the period stated is 0 months you are not covered by this product warranty) following the date of original purchase of the Appliance;
  - (d) 'you' means the purchaser of the Appliance not having purchased the appliance for re-sale, and 'your' has a corresponding meaning.
2. This warranty only applies to Appliances purchased and used in Australia or New Zealand and is in addition to (and does not exclude, restrict, or modify in any way) any non-excludable statutory warranties in Australia or New Zealand.
3. Electrolux warrants that, when dispatched from an Electrolux warehouse, the Appliance is free from defects in materials and workmanship for the Warranty Period.
4. During the Warranty Period Electrolux or its Authorised Service Centre will, at no extra charge if your appliance is readily accessible without special equipment, and subject to these terms and conditions, repair or replace any parts which it considers to be defective. You agree that any replaced Appliances or parts become the property of Electrolux. This warranty does not apply to light globes, batteries, filters or similar perishable parts.
5. Parts and Appliances not supplied by Electrolux are not covered by this warranty.
6. Where you are within an Electrolux service area, this warranty covers the cost of transport of the Appliance to and from Authorised Service Centres of Electrolux and travelling costs for representatives of the Authorised Service Centre to and from your home or business. If you are outside an Electrolux service area, you will bear these costs. For information about whether you are within an Electrolux service area, please phone 13 13 49 in Australia, or 0800 10 66 10 in New Zealand.
7. Proof of purchase is required before you can make a claim under this warranty.
8. You may not make a claim under this warranty unless the defect claimed is due to faulty or defective parts or workmanship. Electrolux is not liable in the following situations (which are not exhaustive):
  - (a) The Appliance is damaged by:
    - (i) accident
    - (ii) misuse or abuse, including failure to properly maintain or service
    - (iii) normal wear and tear
    - (iv) power surges, electrical storm damage or incorrect power supply
    - (v) incomplete or improper installation
    - (vi) incorrect, improper or inappropriate operation
    - (vii) insect or vermin infestation.
  - (b) The Appliance is modified without authority from Electrolux in writing.
  - (c) The Appliance's serial number or warranty seal has been removed or defaced.
  - (d) The Appliance was serviced or repaired by anyone other than Electrolux or its Authorised Service Centres.
9. This warranty, the contract to which it relates and the relationship between you and Electrolux are governed by the law applicable in the Australian State where the Appliance was purchased or the law applicable in New Zealand if the Appliance was

purchased in New Zealand. Where the Appliance was purchased in New Zealand for business purposes the Consumer Guarantee Act does not apply.

## Limitation of Liability

10. To the extent permitted by law:
  - (a) Electrolux excludes all warranties other than as contained in this document;
  - (b) Electrolux shall not be liable for any loss or damage whether direct or indirect or consequential arising from your purchase, use or non-use of the Appliance.
11. Provisions of the Trade Practices Act and State consumer legislation in Australia, and the Consumer Guarantees Act, the Sale of Goods Act and the Fair Trading Act in New Zealand, imply warranties or conditions, or impose obligations, upon Electrolux which cannot be excluded, restricted or modified. To the extent permitted by law, the liability of Electrolux (if any) arising out of or in relation to the Appliance or any services supplied by Electrolux shall be limited (where it is fair and reasonable to do so):
  - (a) in the case of Appliances, at its option, to the replacement or repair of the Appliances or the supply of equivalent products or the payment of the cost of replacing the Appliances or having the Appliances repaired or of acquiring equivalent Appliances. Upon being replaced, parts and Appliances become the property of Electrolux; or
  - (b) in the case of services, at its option, to the supply of the services again or the payment of the cost of having the services re-supplied; and in the case of Appliances or services supplied in New Zealand, loss or damage whether direct or indirect or consequential that is reasonably foreseeable.

## Privacy

You acknowledge that in the event that you make a warranty claim it will be necessary for Electrolux and its Authorised Service Centres to exchange information in relation to you to enable Electrolux to meet its obligations under this warranty.

## EXTENDED WARRANTIES AND INDEMNITY

### Sealed Refrigeration System Warranty

For a further period of three years following the expiry of the Warranty period, Electrolux or its agent will supply replacements for, or at the sole option of Electrolux, repair, all parts it finds defective in the Sealed Refrigeration System which comprises: compressor, condenser, evaporator, dryer and tubing. During this three year period you will pay for the costs of labour (including any call out or service fees), and freight if necessary in replacing defective parts in the Sealed Refrigeration System. You will pay for the costs of transport of the Appliance if further service is required and the costs of parts or repairs to parts other than those included in the Sealed Refrigeration System

### Frozen Food indemnity

Subject to the following exclusions, Electrolux will indemnify you for a period of 24 months from the date of purchase of the Appliance against any loss or damage to frozen foodstuffs due to a Sealed Refrigeration System breakdown. This indemnity will be limited to:

- (a) in the case of freezers with a capacity of less than 400 litres – AU\$150
- (b) in the case of freezers with a capacity of 400 litres or more – AU\$300

This indemnity does not cover loss or damage to frozen foodstuffs occasioned by:

- (a) failure to plug in the freezer to a properly connected power supply or failure to switch on the power point
- (b) accidental removal of the plug from the power point or switching off the power supply;
- (c) failure to keep the door or lid of the freezer closed
- (d) the introduction of abnormal heat loads to the freezer;
- (e) failure to observe the operating and installation instructions supplied with the freezer; and
- (f) failure to defrost the freezer at recommended intervals on chest freezers or non frost free models

## Important Notice

Before Calling a Service Technician please check carefully the operating instructions, service booklet and the warranty terms and conditions.

<p><b>FOR SERVICE</b> or to find the address of your nearest state service centre in Australia <b>PLEASE CALL 13 13 49</b> For the cost of a local call (Australia only)</p>	<p><b>SERVICE AUSTRALIA</b>  ELECTROLUX HOME PRODUCTS www.electrolux.com.au</p>	<p><b>FOR SPARE PARTS</b> or to find the address of your nearest state spare parts centre in Australia <b>PLEASE CALL 13 13 50</b> For the cost of a local call (Australia only)</p>
<p><b>FOR SERVICE</b> or to find the address of your nearest authorised service centre in New Zealand <b>FREE CALL 0800 10 66 10</b> (New Zealand only)</p>	<p><b>SERVICE NEW ZEALAND</b>  ELECTROLUX HOME PRODUCTS www.electrolux.co.nz</p>	<p><b>FOR SPARE PARTS</b> or to find the address of your nearest state spare parts centre in New Zealand <b>FREE CALL 0800 10 66 20</b> (New Zealand only)</p>



For more information on all Westinghouse appliances,  
or for dimension and installation information, call into your retailer,  
phone or email our customer care team or visit our website:

#### AUSTRALIA

phone: 1300 363 640  
fax: 1800 350 067  
email: [customercare@electrolux.com.au](mailto:customercare@electrolux.com.au)  
web: [www.westinghouse.com.au](http://www.westinghouse.com.au)

#### NEW ZEALAND

phone: 09 573 2384  
fax: 0800 363 600  
email: [customercare@electrolux.co.nz](mailto:customercare@electrolux.co.nz)  
web: [www.westinghouse.co.nz](http://www.westinghouse.co.nz)

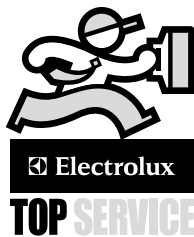

#### TOP SERVICE

Top Service encompasses the after sales service provided by The Electrolux Group to consumers including delivery, home service and spare parts.

**Westinghouse. We are part of the Electrolux family.**  
Share more of our thinking at [www.electrolux.com](http://www.electrolux.com)

© 2009 Electrolux Home Products Pty Ltd ABN 51 004 762 341

Print code: WFRISDUM Issue Date: May 09

**Part Number: Z1926**



**Westinghouse**